

RADIO - ELECTRONICS

OCTOBER 1954

TELEVISION • SERVICING • HIGH FIDELITY

HUGO CERNBACH, Editor

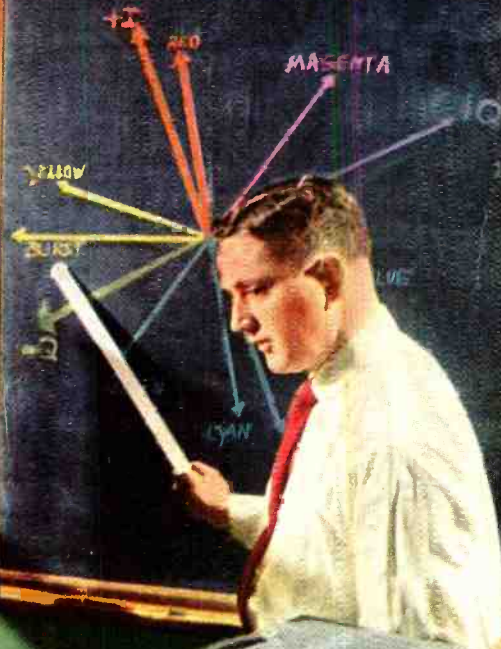

In this issue:

A Wide-Range
Speaker System

U.H.F. Fringe
Installations

TV Cross-Hatch
Generator

Service Techniques
for
Printed Wiring

Electronics
and
Astronomy



35¢

U. S. and
CANADA

Color TV Sends Engineers to School

(See page 4)

Famous ALLIANCE TENNA-ROTOR

...at
*New low
prices*

U-83 was ~~\$4995~~
Deluxe Model—The only fully
automatic antenna rotator on
the market.
NOW \$3495



T-10 was ~~\$3995~~
Finger-tip electrically con-
trolled. Compact and smartly
styled.
NOW \$2995



F-4 was ~~\$3495~~
Economy Model—3-position
switch to control antenna rota-
tor. Reliable.
NOW \$2495

Lowest prices in the industry—Now you can sell famous Alliance Tenna-Rotors easier . . . step up your volume and profits! New, low prices will melt sales resistance.

Quality and style go up . . . prices down—And there's an improvement in Alliance Tenna-Rotor quality that makes the new, reduced prices an even better bargain! Technical improvements are built into Alliance products—users get the benefits of research and progress . . . and at lower prices.

Mass production methods—More than 1,500,000 Alliance Tenna-Rotors are now in use, and the demand keeps climbing. That's why Alliance Manufacturing Co. has stepped up its production—and the economies made are passed along in these sharp price reductions.

Advertising—Alliance Tenna-Rotors are sold most because they are seen most. The vigorous, aggressive advertising program on Alliance Tenna-Rotors carries the story to your customers via TV*, magazines and newspapers. Alliance Tenna-Rotors are pre-sold to make bigger profits for you.

Stock up Now!

**ALLIANCE
MANUFACTURING COMPANY**

ALLIANCE, OHIO



*Alliance ranked No. 14 among all National TV spot advertisers in 1953.

Learn to Service TV Sets—any make or model—Quickly

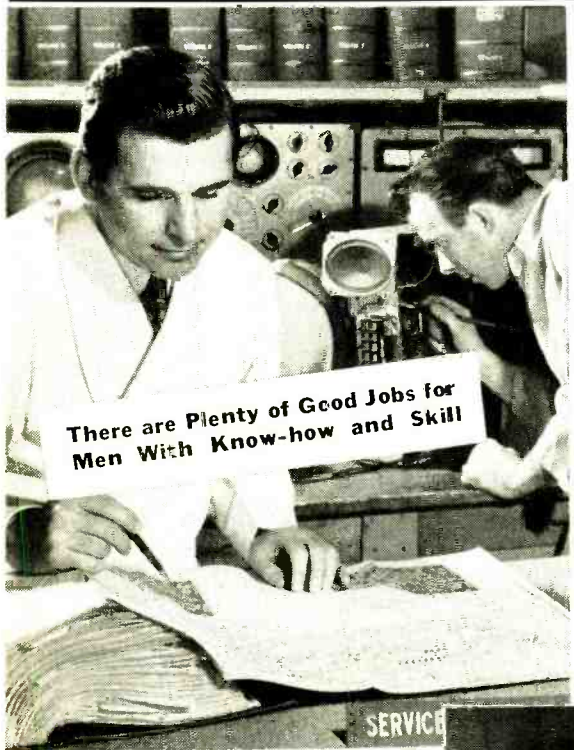

New ALL PRACTICE Method trains you at home to become a Professional TV Serviceman

You learn the time saving techniques, methods used by top TV Servicemen

This is 100% learn-by-doing, practical training. NRI supplies all necessary equipment, all tubes, including a 17-inch picture tube; and comprehensive manuals covering a thoroughly planned program of practice. You learn how experts diagnose TV receiver defects quickly. You easily learn the causes of defects—audio and video—and how to fix them accurately.

You get actual experience aligning TV receivers, isolating complaints from scope patterns, eliminating interference, using germanium crystals to rectify the TV picture signal, adjusting the ion trap and hundreds of other valuable Professional techniques.

17" Picture Tube, Components for a TV Receiver, Scope, Signal Generator, HF Probe—all included in introductory price under \$200—Easy Terms

If you want to go places in TV servicing, you will act quickly to find out what you get, what you practice, what you learn and how NRI's new course in Professional Television Servicing will help you advance through better technical knowledge and training. See pictures of equipment supplied, read what you practice in book offered FREE to ambitious men with some knowledge of Radio or TV fundamentals. Find out about this ALL PRACTICE Professional TV Servicing Course now.

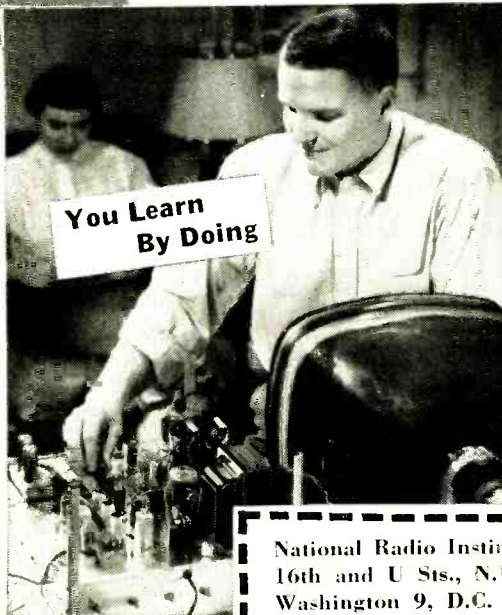

UHF and COLOR Create Growing Opportunities

To cash in on the present UHF and the coming COLOR TV boom you'll need the kind of knowledge and experience NRI's Course gives. You'll get practice installing front-end channel selector strips in modern UHF-VHF receivers. You learn UHF servicing problems and their solution. Mail the coupon now. Discover how NRI's new course in PROFESSIONAL TELEVISION SERVICING meets the needs of the man who wants to get ahead in TV Servicing.

Not for Beginners

If you have some knowledge of Radio-TV fundamentals, or have had some Radio Shop experience or some Radio school training, this course IS FOR YOU. Mail coupon today.

MAIL NOW

COUPON BRINGS IMPORTANT BOOK FREE

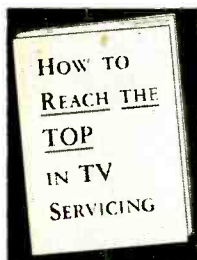

Get this book and judge for yourself how this course will further your ambition to reach the top in TV Servicing or help to build a more secure business of your own in TV. Many of tomorrow's top TV Servicemen . . . men who can service any make, any model, UHF, VHF or Color TV . . . will be graduates of this training. Mail the coupon now. There is no obligation.

National Radio Institute, Dept. 4KFT,
16th and U Sts., N.W.
Washington 9, D.C.

Please send my FREE copy of "How to Reach the Top in TV Servicing."
I understand no salesman will call.

Name..... Age.....

Address

City..... Zone..... State.....

RADIO - ELECTRONICS

Formerly RADIO CRAFT • Incorporating SHORT WAVE CRAFT • TELEVISION NEWS • RADIO & TELEVISION*

Hugo Gernsback
Chairman of the Board
Editor and Publisher

M. Harvey Gernsback,
President
Editorial Director
Fred Shunaman
Managing Editor
Robert F. Scott
W2PWG, Technical Editor
Jerome Kass
Associate Editor
I. Queen
Editorial Associate
Matthew Mandl
Television Consultant
Angie Pascale
Editorial Production
Wm. Lyon McLaughlin
Tech. Illustration Director
Sol Ehrlich
Art Director

Lee Robinson
General Manager
John J. Lamson
Sales Manager
G. Aliquo
Circulation Manager
Adam J. Smith
Director, Newsstand Sales
Robert Fallath
Promotion Manager
Seymour Schwartz
Advertising Production



Member
Magazine Publishers
Association

ON THE COVER

Color TV is as new to many engineers as to service technicians. The cover photograph shows a classroom in the Allen B. Du Mont Laboratories, where engineers are instructed by their more advanced colleagues.

Color original courtesy Allen B. Du Mont Laboratories

CONTENTS

OCTOBER 1954

Editorial (Page 31)			
Service Insurance	by Hugo Gernsback	31	
Test Instruments (Pages 32-39)			
New Instruments for TV Servicing.....	by Robert F. Scott	32	
Linearity Generator for TV.....	by M. J. M. Dunscombe	35	
Phase-Shift Oscillator	by Milton Laikin	37	
Utility Amplifier and Signal Tracer.....	by Alan G. Sorensen	38	
Television (Pages 40-49)			
Tough U.H.F. Installations.....	by C. F. Mahler, Jr.	40	
TV DX (October-December).....		41	
Color TV Circuits, Part V—The I-Q system of color demodulation and its circuitry	by Ken Kleidon and Phil Steinberg	42	
TV Service Clinic	Conducted by Jerry Kass	44	
Television—it's a Cinch (Thirteenth conversation, first half: Positive and negative detection; polarity with one or two v.f. stages; detector component values; push-pull detection, will it work?).....	by E. Aisberg	46	
British TV Standards.....	by Edwin N. Bradley	49	
Electronics (Pages 50-54)			
Univibrators and Flip Flops.....	by Ed Bukstein	50	
Electronics and Astronomy.....	by Guy Slaughter	52	
Audio—High Fidelity (Pages 55-84)			
Wide-Range Speaker System.....	by F. J. Van Alstyne	55	
Distributed Capacitance Nomograph.....	by Joseph F. Sodaro	57	
High-Quality Audio, Part XIV—Negative feedback and its effects on noise, distortion, and frequency response	by Richard H. Dorf	58	
New Electrostatic Speakers.....		61	
High-Fidelity Loudspeakers, Part V—The room and its acoustics, testing speakers, response curves and the human factor.....	by H. A. Hartley	62	
An Interesting Custom Installation.....	by Alvin R. Wisnefski	72	
Dual-Purpose Limiter Amplifier.....	by Hilton L. Remley	77	
Servicing High-Fidelity Equipment, Part VIII—Methods of checking and measuring the tracking angle and needle pressure.....	by Joseph Marshall	82	
Radio (Pages 88-105)			
Techniques for Servicing Printed Wiring.....	by R. E. Ricketts	88	
More on the Ceramic Capacitor.....	by Jesse Dines	94	
An Efficient CW Detector	by Charles Erwin Cohn	103	
DEPARTMENTS			
The Radio Month.....	6	Question Box	126
Correspondence	16	New Devices	128
Technotes	85	Radio-Electronic Circuits	131
Patents	108	Business	135
Technicians' News	116	People	139
New Tubes and Transistors.....	119	Technical Literature	141
Try This One.....	122	Books	144

MEMBER Audit Bureau of Circulations

Vol. XXV, No. 10

Average Paid Circulation over 171,000

RADIO-ELECTRONICS, October 1954, Vol. XXV, No. 10. Published monthly at Mt. Morris, Illinois, by Gernsback Publications, Inc. Entered as Second Class matter June 23, 1954, at the Post Office at Mt. Morris, Ill. Copyright 1954 by Gernsback Publications, Inc. Text and illustrations must not be reproduced without permission of copyright owners. EXECUTIVE, EDITORIAL and ADVERTISING OFFICES: Gernsback Publications, Inc., 25 West Broadway, New York 7, N. Y. Telephone REctor 2-3630. Hugo Gernsback, Chairman of the Board; M. Harvey Gernsback, President; G. Aliquo, Secretary.

SUBSCRIPTIONS: Address correspondence to Radio-Electronics, Subscription Dept., 404 N. Wesley Ave., Mt. Morris, Ill., or 25 West Broadway, New York 7, N. Y. When ordering a change please furnish an address stencil impression from a recent wrapper. Allow one month for change of address.

SUBSCRIPTION RATES: In U. S. and Canada, and in U. S. possessions, \$3.50 for one year; \$6.00 for two years; \$8.00 for three years; single copies 35c. All other foreign countries \$4.50 a year; \$8.00 for two years; \$11.00 for three years.

BRANCH ADVERTISING OFFICES: Chicago: 7522 North Sheridan Road, Tel. Rogers Park 4-8000. Los Angeles: Ralph W. Harker and Associates, 1127 Wilshire Blvd., Tel. MAdison 6-1271. San Francisco: Ralph W. Harker and Associates, 582 Market St., Tel. GARfield 1-2481. FOREIGN AGENTS: Great Britain: Atlas Publishing and Distributing Co., Ltd., London E.C. 4. Australia: McGill's Agency, Melbourne. France: Brentano's, Paris 2e. Belgium: Aence et Messageries de la Presse, Brussels. Holland: Trilectron, Heemstede. Greece: International Book & News Agency, Athens. So. Africa: Central News Agency Ltd., Johannesburg; Capetown, Durban, Natal. Universal Book Agency, Johannesburg. Middle East: Steimatzky Middle East Agency, Jerusalem. India: Broadway News Centre, Dadar, Bombay #14. Pakistan: Paradise Book Stall, Karachi 3. POSTMASTER: If undeliverable send form 3578 to: RADIO-ELECTRONICS, 25 West Broadway, New York 7, N. Y. *Trademark registered U.S. Patent Office.



National Schools brings you a new dimension in training for TELEVISION-RADIO-ELECTRONICS

YOU CAN LEARN BY HOME STUDY, IF—

- you are ambitious to increase your earning power.
- you want to broaden your knowledge and skill.
- you choose the school with the most complete training and service.

50 Years of Successful Training

National Schools has been training men for success since 1905. Our graduates are located around the globe, in good-paying jobs in servicing, installation and manufacturing... in public and private industry, or in their own businesses. All this experience and background are your assurance of success.

What This New Dimension in Home Study Means to You

As a National Schools student, with Shop Method Home Training, you master *all phases* of the industry—TV, Radio, Electronics—theory and practice. You learn *HOW* and *WHY*, in one complete course at one low tuition.

Because National Schools' world headquarters are in Los Angeles—"capital city" of TV-Radio-Electronics—our staff is in close touch with industry. Our lessons and manuals are constantly revised to keep you up-to-the-minute on latest developments. We show you how to make spare time earnings as you learn, and we give you free placement assistance upon graduation. National Schools is approved for G. I. Training. Both Resident and Home Study courses are offered. If you are of draft age, our training helps you achieve specialized ratings and higher pay grades.

This *new dimension* enables us to train you as you should be trained at home, regardless of your age or previous education.

Your Course Includes Valuable Units

We send you important equipment, including a commercial, pro-

fessional Multitester... plus parts to build Receivers, Oscillators, Signal Generator, Continuity Checker, other units, and Short Wave and Standard Broadcast Superhet Receiver.

Mail Coupon for Complete Information

Get these two free books about this new dimension in Home Training. A comprehensive, illustrated fact-book and a sample National Schools lesson. No obligation, so mail coupon today.

NATIONAL SCHOOLS
TECHNICAL TRADE TRAINING SINCE 1905
Los Angeles 37, Calif. · Chicago: 323 W. Polk St.
In Canada: 811 W. Hastings St., Vancouver, B. C.



MAIL NOW TO OFFICE NEAREST YOU!

(mail in envelope or paste on postal card)

NATIONAL SCHOOLS, Dept. RG-104

4000 S. FIGUEROA STREET OR **323 W. POLK STREET**
LOS ANGELES 37, CALIF., OR **CHICAGO 7, ILL.**

Rush **FREE BOOK**, "Your Future in Radio-TV-Electronics," and **FREE LESSON**. No obligation, no salesman will call.

NAME _____ BIRTHDAY _____ 19 _____

ADDRESS _____

CITY _____ ZONE _____ STATE _____

Check if interested **ONLY** in Resident Training at Los Angeles.

VETERANS: Give date of discharge _____

**for PA
LIKE ON TV**

**636
Slimair
DYNAMIC
MICROPHONE**

Gives you features similar to those in the famous E-V Slim-Trim TV Microphones. That's why it is so outstanding for Public Address, Recording and other general-purpose use.
List Price \$70

**SMOOTH RESPONSE
60-13,000 CPS
HIGH OUTPUT
OMNIDIRECTIONAL
ACOUSTALLOY
DIAPHRAGM
BUILT-IN
BLAST FILTER**

Can be used in the hand, on a stand, or overhead

SEND FOR BULLETIN

Electro-Voice
421 CARROLL ST. - BUCHANAN, MICH.
Export: 13 E. 40th St., N. Y. 16, U.S.A.

the Radio month



FIRST COLOR TV DX pickup may have taken place on July 11 when the color bar pattern of KPRC-TV, Houston, was received by R. K. Lockhart in Moorestown, N. J. The signal was picked up for about 19 minutes shortly after noon, on an RCA C-100 color receiver. Lockhart reported the color quality good.

EDUCATIONAL TELEVISION is continuing to grow as shown by the announcement that the fourth and fifth stations have qualified for grants under the Emerson Radio and Phonograph Corporation plan to give \$10,000 to each of the first 10 educational stations.

In presenting checks to stations KQED, San Francisco, and WHA-TV, Madison, Wis., Benjamin Abrams, president of Emerson, said, "This is a tremendous step forward but it has been made possible only by the combined support of civic and educational leaders and the general public in each of the five areas."

PHILCO COLOR TV TUBE may soon make its appearance. Although Philco has already delivered some tube manufacturing equipment to its licensees, it admits "a lot of invention is still needed." Complex receiver circuitry appears to be the main stumbling block.

The tube will be of single-gun construction with a 250-square-inch picture area on a 21-inch rectangular tube. It will use the same glass bulb as present-day monochrome tubes. The phosphors are applied to the face photographically.

U.H.F. SATELLITES will come into being as a result of an FCC ruling. These stations will rebroadcast programs from a master station at different frequencies. The FCC action was taken to help further u.h.f. development.

Under the ruling, a v.h.f. or u.h.f.

station may have its owned-and-operated u.h.f. satellites in near-by areas carrying exactly the same programs as the master station. In all other respects, the satellites will have to meet FCC rules for TV stations.

Experimenting with equipment suitable for such applications, RCA has recently completed field tests on a u.h.f. TV booster system in cooperation with station WJTV, channel 25, Jackson, Miss. The tests explored the possibility of extending u.h.f. TV service into areas blacked out by geographic conditions.

The booster system consists of a low-power auxiliary transmitter (power may have to be increased to meet the FCC rules as proposed at present), a highly directional receiving array, and amplifying equipment. The booster equipment receives the original signal from the station's main transmitter, amplifies it, and then broadcasts the amplified signal throughout the local area where signals from the main station are weak.

(Continued on page 10)

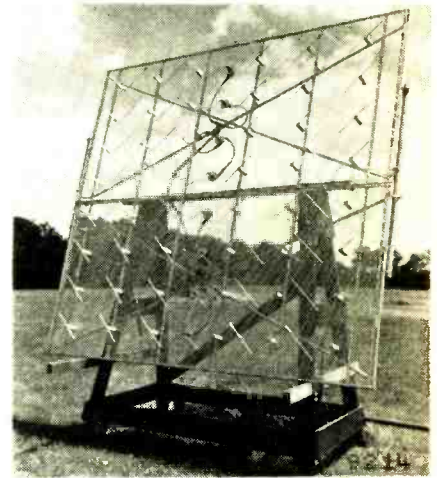

Receiving antenna for booster system.

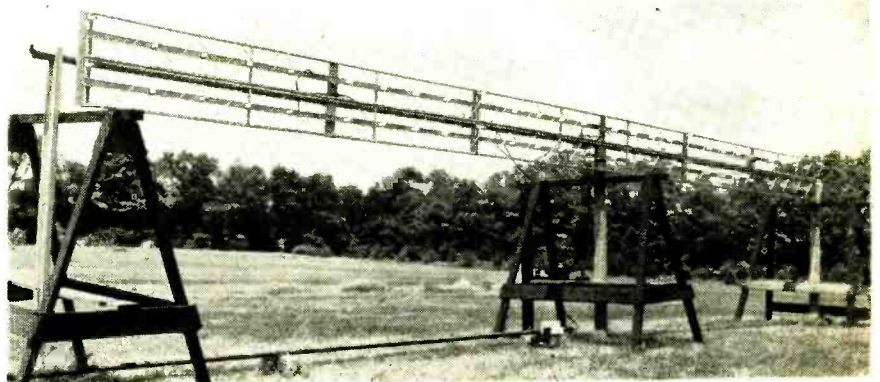

Transmitting antenna for booster system.

Prepare Now... in spare time at Home ... for a New,

PROFITABLE, INTERESTING FUTURE



W. C. DeVRY, Director

TELEVISION
RADIO - ELECTRONICS

RADIO CHIEF OF ILE DE FRANCE
FRENCH LUXURY LINER PRAISES D. T. I.

Radio Chief—Jean Desmas Says:

"Your Training Organization in Chicago is known not only throughout Europe, but also in many parts of the world as one of America's finest Television, Radio and Electronics training centers."

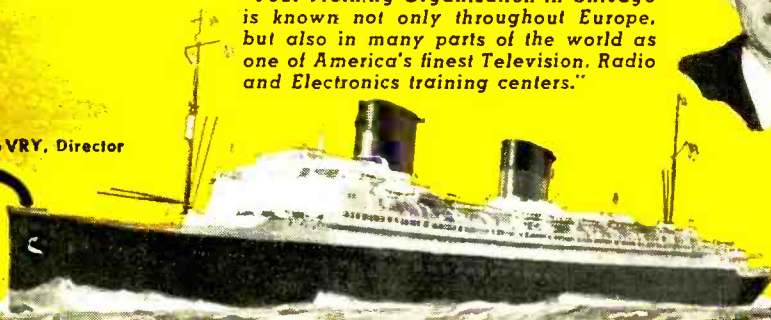

**W. C. DeVRY TELLS OF
BIG OPPORTUNITY
AWAITING MEN 17-45**

Urges them to send for facts today

"Many D.T.I. graduates are earning real money in TV Stations... A.M. and F.M. Radio Stations... Television Manufacturing Plants... Research Laboratories... Police, Train and Car Radio... Aviation Radio... Industrial Electronics... Sound Motion Pictures... Electronic Musical Instrument Plants... the Hearing Aid Industry... and in many other branches of this great and growing opportunity field.

"Mail coupon today for the latest facts about these many wonderfully interesting opportunities facing you... and HOW you may now get the same remarkable training—and subsequent EMPLOYMENT SERVICE—that have already enabled so many men to get started in a good job or their own profitable business. There's NOTHING ELSE LIKE IT!"

Prepare At Home Or In Our Chicago Laboratory!

See for yourself how readily you may prepare at home, or in our modern Chicago laboratories, for a good job or business of your own in one of America's most promising, fast-growing fields—TELEVISION-RADIO-ELECTRONICS.

If you train at home you get (1) the use of a 16-mm. movie projector and 16 reels of animated movies to help you learn important points faster... easier, (2) modern, well illustrated lessons and (3) sixteen shipments of electronic parts enabling you to get valuable practical experience from over 300 projects—including building and keeping the electronic equipment shown below. And upon completing training, you have the optional privilege of building and keeping a big 21 INCH TV Set. (D.T.I. offers another home training in Television-Radio-Electronics, but without the TV set.) Get the full story. Mail coupon today!

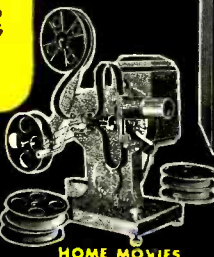

HOME MOVIES



MULTIMETER



5 INCH "SCOPE"



21 INCH

Build and keep his BIG DTI Engineered TV set—easily converted to U.H.F. DTI offers another home training, but without the TV set.

**LAUD D. T. I.'s
HOME MOVIES
IN CONGRESS**

D.T.I.'s remarkable home training benefit of visual training MOVIES has been praised from the floor of the House of Representatives in Washington, D. C. and recorded in The Congressional Record.



MILITARY SERVICE!

If subject to military service, the information we have for you should prove very helpful. Mail coupon today.



"One of America's Foremost Television Training Centers"

89 WAYS TO EARN MONEY IN TELEVISION RADIO ELECTRONICS

MAIL COUPON TODAY!

DEVRY TECHNICAL INSTITUTE
4141 BELMONT AVE., CHICAGO 41, ILL. Dept.

RE-10K

I would like your valuable information-packed publication showing how I may get started toward a good job or my own business in Television-Radio-Electronics.

Name _____ Age _____
Street _____ Apt. _____
City _____ Zone _____ State _____

D. T. I.'s Training is Available in Canada

DEVRY TECHNICAL INSTITUTE

AFFILIATED WITH

DEFOREST'S TRAINING, INC.

CHICAGO 41, ILLINOIS



**Better Contrast!
Longer Life!
Availability!**

SYLVANIA
*Aluminized
Picture Tubes*
**ARE PACKED
WITH PROFITS!**

Make old sets like new... have more satisfied customers!

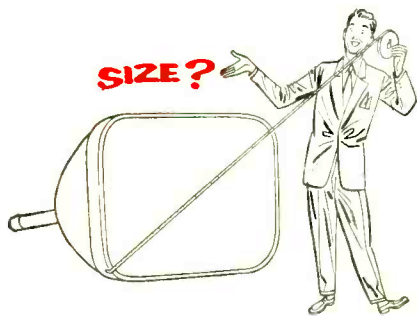

Interested in new sales records? You'll be heading in that direction when you replace old picture tubes with new Sylvania Aluminized Tubes.

Sylvania Aluminized Picture Tubes give terrific performance. They make old sets better and brighter than new by providing whiter whites—blacker blacks . . . a 6-times better picture contrast.

Sylvania Aluminized Picture Tubes are now available in most sizes for all popular TV sets. In other words, with Sylvania Aluminized Picture Tubes, you give your customers the best possible buy *and* the best possible service, including a full one-year warranty.

Remember, millions of set owners see and hear about Sylvania Picture Tubes on the nation-wide weekly television show "Beat The Clock." They know that they are famous for quality and dependability. For full details about aluminized tube replacement, write for Sylvania's "Aluminized Picture Tube Replacement Guide." Address: Dept. 4R-3810, Sylvania NOW!

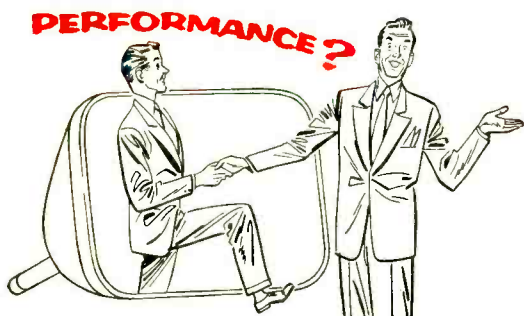
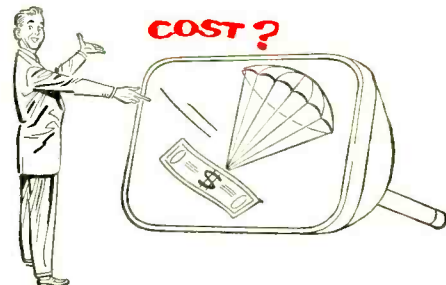

SYLVANIA

Sylvania Electric Products Inc.  1740 Broadway, New York 19, N. Y.

In Canada: Sylvania Electric (Canada) Ltd.
University Tower Building, St. Catherine Street, Montreal, P. Q.

LIGHTING • RADIO • ELECTRONICS • TELEVISION

RADIO-ELECTRONICS

NEW!



SABRE

with

model 100

Miracle Phase*

Patent Applied For

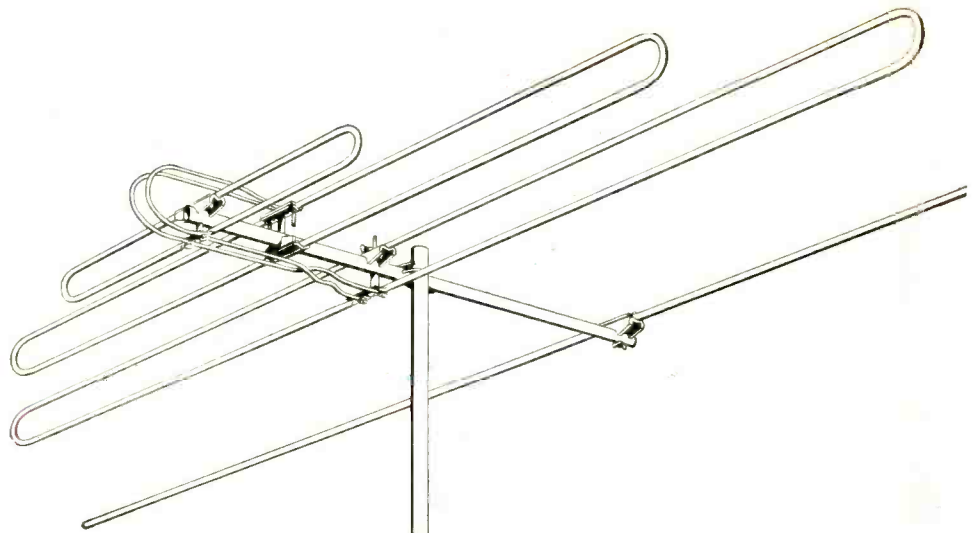

look at these outstanding sales features

- Compact size—makes it easy to handle—to stock—and safe to install
- A sturdy streamlined design that will stand up under extreme weather and icing conditions
- Completely pre-assembled — with fold out construction
- Sealed element ends eliminate wind noise
- Ideal with rotor either singly or stacked
- Uniform low band coverage (2-6) and excellent high band gain (7-13)
- High front to back ratio cuts co-channel interference
- Sharp directivity and ultra linear response for excellent black and white and color reception
- 300 ohm match
- Only the Welco Sabre has Miracle Phase*

One Antenna that fills your VHF needs close in — to extreme fringe and UHF

Miracle Phase

Miracle Phase effectively isolates the undesirable interaction and loading of Phased elements. As used with a bi-philler broadening and phase inverting element, it allows the low band dipole to function with proper gain and pattern response in the high band. This unique coupling of working elements makes it possible to feed the received signal to the set so satisfactorily that the need for many additional elements is eliminated — greatly reducing the physical size of high gain antennas — thus allowing one antenna to fill many requirements — and become the first choice of servicemen.

introduces a New Look in all channel antenna design



ORDINARY ANTENNA

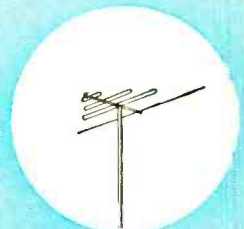

SABRE 100

Compare Sabre 100 performance, size and price with other antennas

The Welco SABRE cannot be compared with any other antenna design—because electrically it works different—physically it appears different. The SABRE is compact, streamlined and its new phasing system gives it added distinction. All this at a price that will amaze the most discriminating people, thus making the SABRE a tremendous sales getter.

THERE'S A SABRE MODEL FOR EVERY AREA FOR TODAY'S NEEDS AS WELL AS TOMORROW'S!

watch the Sabre create a new standard in antenna design and appearance

Distributor Inquiries Invited—Territories for the New Sabre Line Now Open Write, wire or phone—

WELCO MFG. CO.

Leaders in Electronic Design

225 S. Third Street

P.O. Box 110

Burlington, Iowa

TUNG-SOL TECHNICAL DATA PAYS OFF IN SERVICE!

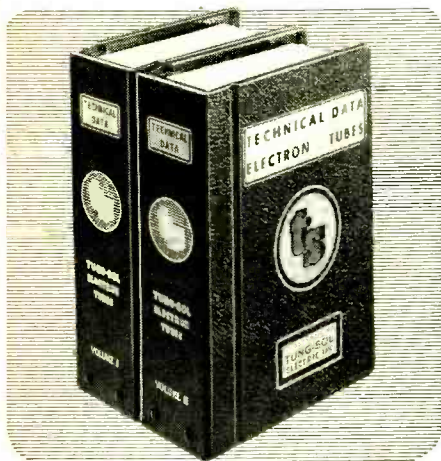

T-58 700 pages—600 tube types



NEW! 1954 Edition! T-70 200 pages of data on CR tubes, receiving and special tubes, dial lamps



T-31 300 blueprint base diagrams for 1100 tube types

Here's the most practical set of tube reference books in the industry—all the information you need for everyday jobs! They're easy to read—easy to use (always lie flat when open). You'll get work done faster with Tung-Sol Technical Data Books. Ask your tube supplier about them.

TUNG-SOL ELECTRIC INC., Newark 4, N. J.
Sales Offices: Atlanta, Chicago, Columbus, Culver City (Los Angeles), Dallas, Denver, Detroit, Newark, Seattle.

TUNG-SOL
easy reference
TECHNICAL DATA

Tung-Sol makes All-Glass Sealed Beam Lamps, Miniature Lamps, Signal Flashers, Picture Tubes, Radio, TV and Special Purpose Electron Tubes and Semiconductor Products.

X-RAY HAZARD was laid to receivers using recently developed large-screen 3-gun color tubes by an official of Chromatic Labs, producer of the 1-gun Lawrence tube. He stated the high voltage necessary for the 3-gun tubes produces substantial amounts of X-ray radiation—enough to cause considerable physical damage to viewers unless blocked by expensive shielding.

In reply, Kenneth Hoagland, engineering manager of Du Mont's C-R tube division, said the problem of X-ray radiation had been under study for some time. He said RETMA has adopted a standard of 6.25 milliroentgens per hour as the safe figure for radiation from a cathode-ray tube.

Hoagland said any tube operating under 16 kv is definitely harmless. Over that amount, shielding may be required to bring radiation down to below the safe figure. He added that the safe figure was an ultra-conservative one and that tubes have been operated in the laboratory up to 35 kv without producing damaging radiation.

Charles F. Stromeyer, president of CBS-Hytron, admitted that soft X-rays are given off at 25 kv, but said they are absorbed in the face plate of the CBS Colortron.

EIGHT NEW TV STATIONS have gone on the air since our last report. These are:

WGTH-TV	Hartford, Conn.	18
WTHI-TV	Terre Haute, Ind.	10
WPBN-TV	Traverse City, Mich.	7
WTVD	Durham, N.C.	11
WGR-TV	Buffalo, N.Y.	2
KXJB-TV	Valley City, N.D.	4
WACH-TV	Newport News-Norfolk, Va.	33
WMBV-TV	Marinette, Wis.	11
Five stations have gone off the air:		
WKAB-TV	Mobile, Ala.	48
KBID-TV	Fresno, Calif.	53
WCOC-TV	Meridian, Miss.	30
KSTM-TV	St. Louis, Mo.	36
WCHA-TV	Chambersburg, Pa.	46

THE AUDIO FAIR, held in conjunction with the annual convention of the Audio Engineering Society, will be held at the Hotel New Yorker, New York City, October 14 to 17.

RADIO-ELECTRONICS will occupy Room 716 at the exhibit. Mr. Joseph Marshall of "Golden Ear" fame will appear at the RADIO-ELECTRONICS booth to meet his audio friends and demonstrate some of his recent equipment.

RADIO WEATHER FORECAST predicts unusually good transmission conditions for the balance of 1954. This report was made by John H. Nelson, radio-wave analyst of RCA Communications. He bases his forecasts of troublesome magnetic storms on the position of the planets in relationship with each other and the sun, and boasts 92% accuracy for the first 6 months of the year.

While radio disturbances since 1925 have been attributed largely to sunspots, Nelson said none of his forecasts this year were from solar observations.

COMBAT TV was given its first truly

public demonstration when military TV maneuvers at Fort Meade, Md., were telecast from coast to coast on the NBC network in color. The tactical combat maneuvers were also watched "on location" by top Army officers using closed circuit black-and-white equipment.

Eight remote TV cameras were used in the exercises. Their signals were piped into a simulated regimental command post. The cameras were mounted in an L-2 Army plane. Helicopters, assault landing craft, and fixed positions covered various phases of operations, including an amphibious landing.

The maneuvers televised in color showed the destruction of "enemy" pillboxes, questioning of "enemy" prisoners—distinguished by their blue uniforms—and other battle occurrences.

Viewing the scene, General Sarnoff of RCA said that further development may make it possible for military commanders sitting in the Pentagon to watch actual battle scenes overseas.

QUARTER CENTURY WIRELESS Association will hold its 1954 winter meeting on October 29 at the Hotel Belmont Plaza, New York City. A talk on single-sideband transmission will be given by Don Norgaard, W2KUJ, a research engineer for General Electric.

Organized in 1947 to foster friendship among ham operators, the QCWA now has an active membership of more than 700. Full membership is open to amateurs who have held licenses for 25 years or longer. Officers are John DiBlasi, W2FX, president; George T. Droste, W2IN, vice-president; David Talley, W2PF, treasurer, and Ralph G. Barber, W2ZM, secretary.

ATOM DEFENSE IS PERILED by illegal diathermy, industrial heating, and electronic equipment. The FCC reports this equipment interferes with the effectiveness of the airplane warning system because it disrupts radio circuits in the radar network.

The illegal equipment is believed to be largely in the hands of doctors and businessmen unaware of the radiation situation. Nevertheless it would provide an ideal weapon for saboteurs attempting to disrupt military communications or guide enemy planes.

It also provides a virtually foolproof method of transmitting subversive information to enemies through coded signals based on the time of day the machine goes into operation and the length of time it is kept on.

The situation has become so serious that William L. Kiser of the FCC's New York office warned: "The commission does not intend to rely solely on an education campaign to curb the use of these illegal machines. It intends to use every means at its disposal to identify and eliminate the use of any equipment which does not comply with its rules."

Mr. Kiser added that the signals of some of these machines can be heard around the world. It might be possible for enemy guided missiles to "home" on these illegal machines. **END**

Six months from today

Which Will You Hold?

this-

or this

REGRET TO ADVISE YOU FAILED YOUR FCC EXAMINATIONS-

1st CLASS RADIO TELEPHONE OPERATOR'S LICENSE

Add Technical Training To Your Practical Experience - **GET YOUR FCC LICENSE IN A HURRY!**

Then use our Amazingly Effective **JOB-FINDING SERVICE**

Money-Making **FCC** Commercial Radio Operator **LICENSE** Information

Get This Valuable Booklet

TV ENGINEERING INCLUDED IN OUR TRAINING & COACHING

FREE!

● TELLS HOW -

Here Is Your **GUARANTEE**

If you fail to pass your Commercial License exam after completing our course, we guarantee to continue your training without additional cost of any kind until you successfully obtain your Commercial license, provided you first sit for this examination within 90 days after completing your course.

WE GUARANTEE

TO TRAIN AND COACH YOU AT HOME IN SPARE TIME UNTIL YOU GET

YOUR FCC LICENSE

If you have had any practical experience—Amateur, Army, Navy, radio repair, or experimenting.

● TELLS HOW -

Employers make **JOB OFFERS** Like These to Our Graduates Every Month

Letter from nationally-known Airlines, "We would also appreciate if you would place the following additional advertisement in your bulletin-Wanted-Superintendent of Communications . . . Salary \$696.66 per month."

Letter from nationally-known airplane manufacturer, "We need men with electronic training or experience in radar maintenance to perform operational check-out of radar and other electronics systems . . . starting salary . . . amounting to \$329.33 per month."

These are just a few samples of the job offers that come to our office periodically. Some licensed radioman filled each of these jobs . . . it might have been you!

HERE'S PROOF FCC LICENSES ARE OFTEN SECURED IN A FEW HOURS OF STUDY With OUR Coaching AT HOME in Spare Time.

Name and Address	License	Lessons
Lee Worthy 2910 1/2 Wilshire St., Bakersfield, California	2nd Phone	16
Clifford E. Vogt Box 1016, Dania, Florida	1st Phone	20
Francis K. Foersch 38 Beuter Pl., Bergenfield, New Jersey	1st Phone	38
S/Sgt. Ben H. Davis 317 North Roosevelt, Lebanon, Illinois	1st Phone	38
Albert Schoel 110 West 11th St., Escondido, California	2nd Phone	23

Carl E. Smith, E.E., Consulting Engineer, President

CLEVELAND INSTITUTE OF RADIO ELECTRONICS
DESK RE-69, 4900 Euclid Bldg., Cleveland 3, Ohio

● TELLS HOW -

Our Amazingly Effective **JOB-FINDING SERVICE** Helps **CIRE** Students Get Better Jobs

Here are a few recent examples of Job-Finding results:

GETS CIVIL SERVICE JOB

"Thanks to your course I obtained my 2nd phone license, and am now employed by Civil Service at Great Lakes Naval Training Station as an Engineering Specialist."
Kenneth K. Leiser, Fair Oaks, Mtd. Del., McHenry, Md.

GETS STATE POLICE JOB

"I have obtained my 1st class ticket (thanks to your school) and since receiving same I have held good jobs at all times. I am now Chief Radio Operator with the Kentucky State Police."
Edwin P. Healy, 264 E. 3rd St., London, Ky.

GETS BROADCAST JOB

"I wish to thank your Job-Finding Service for the help in securing for me the position of transmitter operator here at WCAE, in Pittsburgh."
Walter Kosechik, 1442 Ridge Ave., N. Braiddock, Pa.

GETS AIRLINES JOB

"Due to your Job-Finding Service, I have been getting many offers from all over the country, and I have taken a job with Capital Airlines in Chicago, as a Radio Mechanic."
Harry Clare, 4537 S. Drexel Blvd., Chicago, Ill.

Your FCC Ticket is recognized by most employers in the electronic field as proof of your technical ability.

Get All 3 Free

MAIL COUPON NOW

CLEVELAND INSTITUTE OF RADIO ELECTRONICS
Desk RE-69—1900 Euclid Bldg., Cleveland 3, Ohio
(Address to Desk No. to avoid delay)

I want to know how I can get my FCC ticket in a minimum of time. Send me your **FREE** booklet, "How to Pass FCC License Examinations" (does not cover exams for Amateur License), as well as a sample FCC-type exam and the valuable booklet, "Money-Making FCC License Information." Be sure to tell me about your Television Engineering Course.

B

NAME
ADDRESS
CITY ZONE STATE

For prompt results, send airmail.
Special tuition rates to members of the U.S. Armed Forces.

ANOTHER RAYTHEON FIRST!

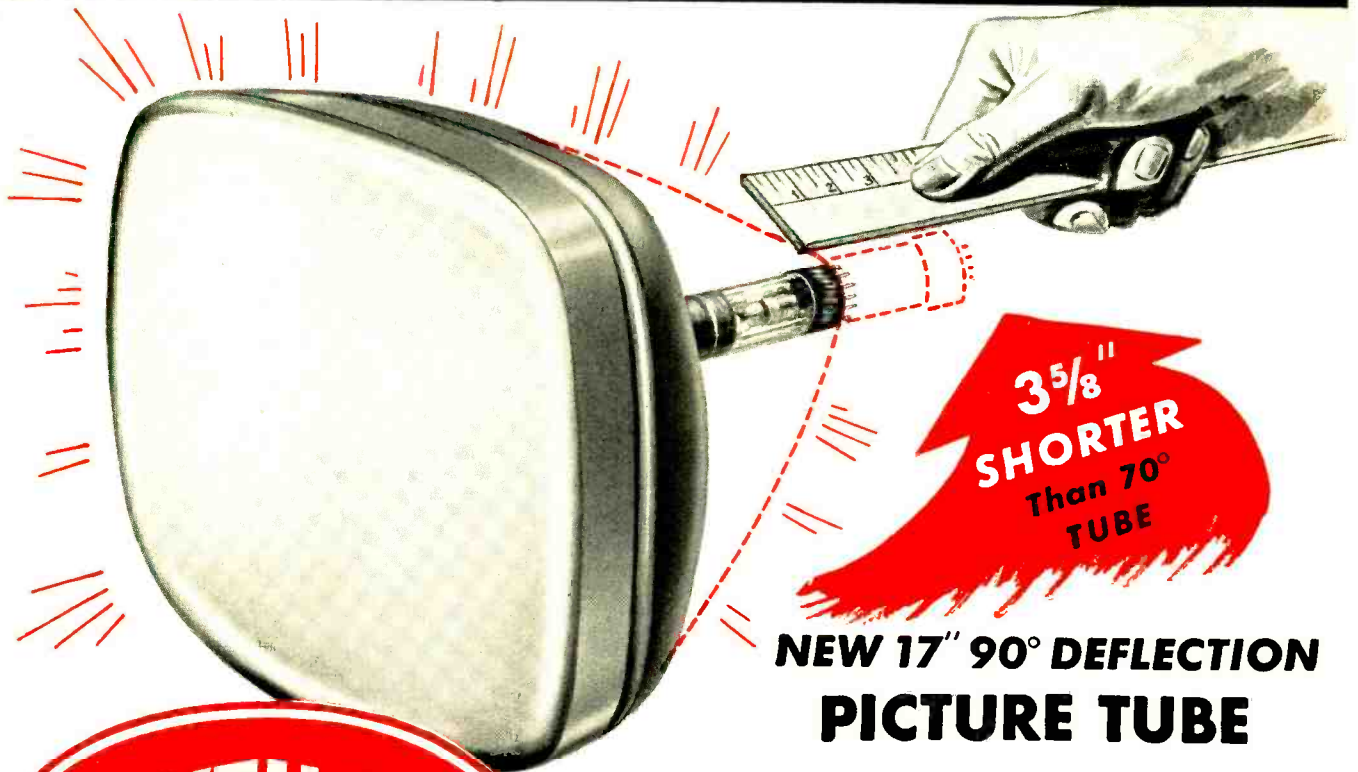

RAYTHEON 17AVP4

Raytheon leads the way to smaller, light weight, more compact, television receivers with the amazing new 17AVP4 monochrome picture tube. It is $3\frac{5}{8}$ inches shorter in overall length and approximately 4 pounds lighter than present 17 inch tubes. The type 17AVP4 incorporates a new 90° deflection angle bulb, a 1 inch shorter neck length and achieves maximum compactness with conventional viewing area. The 17AVP4 has electrostatic focus, magnetic deflection and features the same crisp, clean picture that makes all Raytheon Picture Tubes outstanding for quality.

This important new Raytheon tube, developed and produced at Raytheon's new modern picture tube plant at Quincy, Massachusetts is one more reason why you can standardize on Raytheon Picture Tubes with complete confidence that you are giving your customers the very latest and best.

Remember, Raytheon Picture Tubes are Right for Sight, Right for You, and always New. Buy them through your nearest Raytheon Tube Distributor.

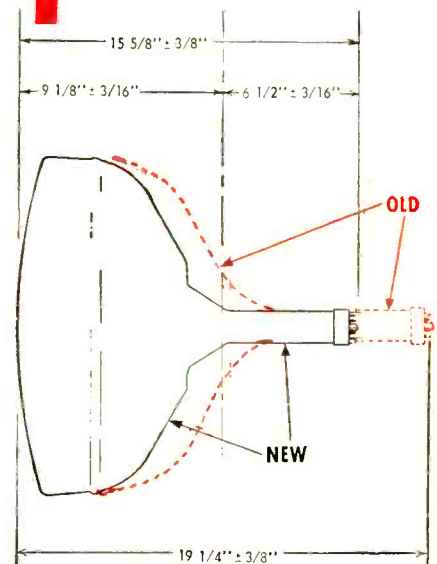

Excellence in Electronics

RAYTHEON MANUFACTURING COMPANY

Receiving and Cathode Ray Tube Operations
 Newton, Mass., Chicago, Ill., Atlanta, Ga., Los Angeles, Calif.

RAYTHEON MAKES ALL THESE:

RECEIVING AND PICTURE TUBES • RELIABLE SUBMINIATURE AND MINIATURE TUBES • SEMICONDUCTOR DIODES AND TRANSISTORS • NUCLEONIC TUBES • MICROWAVE TUBES

How I foxed the Navy

by Arthur Godfrey



The Navy almost scuttled me. I shudder to think of it. My crazy career could have ended right there.

To be scuttled by the Navy you've either got to do something wrong or neglect to do something right. They've got you both ways. For my part, I neglected to finish high school.

Ordinarily, a man can get along without a high school diploma. Plenty of men have. But not in the Navy. At least not in the U. S. Navy Materiel School at Bellevue, D. C., back in 1929. In those days a bluejacket had to have a mind like Einstein's. And I didn't.

"Godfrey," said the lieutenant a few days after I'd checked in, "either you learn mathematics and learn it *fast* or out you go. I'll give you six weeks." This, I figured, was it. For a guy who had to take off his shoes to count

above ten, it was an impossible assignment.

I was ready to turn in my bell-bottoms. But an ad in a magazine stopped me. Here, it said, is your chance to get special training in almost any subject—mathematics included. I hopped on it. Within a week I was enrolled with the International Correspondence Schools studying algebra, geometry and trig for all I was worth.

Came week-end liberty, I studied. Came a holiday, I studied. Came the end of the six weeks, I was top man in the class. Within six weeks I had mastered two years of high school math, thanks to the training I'd gotten.

I.C.S. made the impossible—easy!

GET EXPERT GUIDANCE 2 FREE BOOKS

Free, illustrated catalog on career that interests you. Also 36-page, pocket-size guide to advancement, "How to Succeed." Just mail the coupon!

For Real Job Security—Get an I. C. S. Diploma!

I. C. S., Scranton 9, Penna.

INTERNATIONAL CORRESPONDENCE SCHOOLS



BOX 2880-L. SCRANTON 9, PENNA.

(Partial list of 277 courses)

Without cost or obligation, send me "HOW TO SUCCEED" and the opportunity booklet about the field BEFORE which I have marked X:

ARCHITECTURE and BUILDING CONSTRUCTION

- Air Conditioning—Refrig.
- Architecture
- Building Contractor
- Building Maintenance
- Carpenter and Mill Work
- Estimating
- Heating
- Painting Contractor
- Plumbing
- Reading Arch. Blueprints
- Steamfitting

ART

- Cartooning
- Commercial Art
- Fashion Illustrating
- Magazine Illustrating
- Show Card and Sign Lettering
- Sketching and Painting

AUTOMOTIVE

- Auto Body Rebuilding
- Auto Elec. Technician
- Auto-Engine Tune Up
- Automobile Mechanic

AVIATION

- Aeronautical Engineering Jr.
- Aircraft & Engine Mechanic

BUSINESS

- Advertising
- Bookkeeping and Accounting
- Business Administration
- Business Correspondence
- Certified Public Accounting
- Creative Salesmanship
- Federal Tax
- Letter-writing Improvement
- Managing Small Business
- Office Management
- Retail Business Management
- Sales Management
- Stenographic-Secretarial
- Traffic Management

CHEMISTRY

- Analytical Chemistry
- Chemical Engineering
- Chem. Lab. Technician
- General Chemistry
- Natural Gas Prod. & Trans.
- Petroleum Engineering
- Plastics
- Pulp and Paper Making

CIVIL, STRUCTURAL ENGINEERING

- Civil Engineering
- Construction Engineering
- Highway Engineering
- Reading Struct. Blueprints
- Sanitary Engineering
- Structural Engineering
- Surveying and Mapping

DRAFTING

- Aircraft Drafting
- Architectural Drafting
- Electrical Drafting
- Mechanical Drafting
- Mine Surveying and Mapping
- Ship Drafting
- Structural Drafting

ELECTRICAL

- Electrical Engineering
- Electrical Maintenance
- Electrician Contracting
- Lineman

HIGH SCHOOL

- Commercial
- Good English
- High School Subjects
- Mathematics

LEADERSHIP

- Foremanship
- Industrial Supervision
- Leadership and Organization
- Personnel-Labor Relations

MECHANICAL AND SHOP

- Gas—Electric Welding
- Heat Treatment Metallurgy
- Industrial Engineering
- Industrial Instrumentation
- Industrial Supervision
- Machine Design-Drafting
- Machine Shop Inspection
- Machine Shop Practice
- Mechanical Engineering
- Quality Control
- Reading Shop Blueprints
- Refrigeration
- Sheet Metal Worker
- Tool Design Toolmaking

RADIO, TELEVISION

- Electronics
- Practical Radio—TV Eng'ring
- Radio and TV Servicing
- Radio Operating
- Television—Technician

RAILROAD

- Air Brakes Car Inspector
- Diesel Locomotive
- Locomotive Engineer
- Section Foreman
- Steam and Diesel Power
- Combustion Engineering
- Diesel—Elec. Diesel Eng's
- Electric Light and Power
- Stationary Fireman
- Stationary Steam Engineering

TEXTILE

- Carding and Spinning
- Cotton, Rayon, Woolen Mfg.
- Finishing and Dyeing
- Loom Fixing
- Textile Designing
- Textile Eng'g Throwing
- Warping and Weaving

MISCELLANEOUS

- Domestic Refrigeration
- Marine Engineering
- Ocean Navigation
- Shipfitting
- Short Story Writing
- Telephony

Name _____ Age _____ Home Address _____

City _____ Zone _____ State _____ Working Hours _____ A.M. to P.M. _____

Occupation _____

Canadian residents send coupon to International Correspondence Schools, Canadian, Ltd., Montreal, Canada. . . . Special tuition rates to members of the U. S. Armed Forces.

Exclusive!
Electro-Lens
Focusing*!



get sharper...
MUCH SHARPER...
 pictures

Give your customers the most sparkling pictures they've ever hoped for . . . pictures with all the dramatic highlights and tones of a portrait photograph . . . with the revolutionary new Winegard Interceptor TV Antenna! Restores vibrant life to the dull, blurred image of many old sets . . . brings out every last ounce of performance in the newest.

For only the Interceptor has that amazing "Electro-Lens Focusing" . . . the patented design that pulls in all the signal . . . actually builds up its intensity . . . then focuses the amplified signal to the screen, much as an

optical lens focuses and intensifies light rays.

And—the Interceptor gives maximum rejection of side and back interference . . . vastly superior reception in outlying areas. Particularly suited to color TV, designed to give performance unmatched by any other antenna on all VHF channels. Lightweight, compact, wind resistant.

An obsolete antenna can make even the finest set unsatisfactory. So give your customers the best performance from any set, old or new . . . insure their utmost satisfaction. Write for complete information about the Winegard Interceptor Antenna today!

*Patent Pending



WINEGARD **Interceptor** **ANTENNA**

with Exclusive Electro-Lens Focusing

WINEGARD COMPANY, 3000 Scotten Boulevard, Burlington, Iowa

Now EVERYBODY CAN HAVE A "QUICK-HOT" ELECTRONIC SOLDERING GUN



120 V. A.C.
60 CYCLE
1.1 AMP. MAX.



WORKING HOT
IN 2½ SECONDS

THE NEW **WEN**
MODEL #199

Costs Only \$7.95 RETAIL

and it's ideal for the work you do

It's smaller, lighter—slips readily into tool kit or pocket. Gives AMPLE heat—fast. Cools quickly too. Has wonderful balance. WEIGHS ONLY 1½ LBS. Easier to use accurately—less firing. Its extra long narrow tips (replaceable) make it easy to reach tight spots. And they

are new type steel nose LIFETIME TIPS—practically indestructible in ordinary use. Built-in spotlight automatically illuminates work. Cherry red plastic handle and case are heat and shock resistant. Gun is well made throughout—fully guaranteed. And that price!

FOR HEAVY DUTY
THERE'S THE FAMOUS
WEN 250 WATT "QUICK-HOT"



567 HOURS
CONTINUOUS OPERATION

Ideal for many production jobs, maintenance, repairs, intermittent soldering. Delivers more heat so can solder heavier metals. With special tip cuts plastic tile. Fully guaranteed.

RETAILS **\$12.95**

OTHER POCKET PORTABLES
YOU'LL WANT
TO OWN

SUPER-POWER SANDER
MODEL #303

Light (2½ lbs.)—compact, handy. 120 V. A.C. 60 cycle, 14,400 strokes P.M., straight line action. Kit is Sander, 12 Sandpapers, 2 Polishing Cloths.



SANDER-POLISHER
MODEL #202

For fine finishing. 120 V. A.C. 60 cycle straight line action; no scratches, reaches corners. Also polishes car, etc. **\$13.95** only

RETAILS **\$16.95**

COMPLETE KIT



PRODUCTS, INC.

5808 NORTHWEST HIGHWAY
CHICAGO 31, ILL.

(Export sales, Scheel International, Inc., Chicago)

the BOOSTER with the CASCODE CIRCUIT

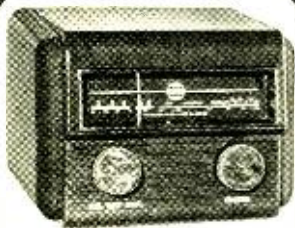

Turner:
Model TV-2

...for sharper reception
on any set — new or old!

We'll give it to you straight. This booster costs a little more. *It's worth it!* Who wants to watch Milton Berle through a blizzard of snow. The high-quality cascode circuit in the Turner booster reduces noise and snow to a minimum. Produces an excellent picture even in extreme fringe areas. Many servicemen say, "The Turner is the *only* booster that will help the new sets with cascode tuners." *Install* a Turner booster and you guarantee the best possible reception.

THE TURNER COMPANY



- The TURNER Company
- 933 17th Street N.E.,
- Cedar Rapids, Iowa
- Gentlemen: Please send me complete information on the superior performance of your booster.
- Name _____
- Address _____
- City _____ State _____

Correspondence

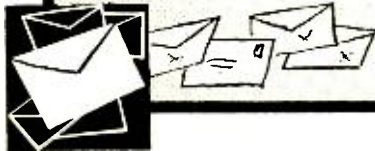

VENEZUELA TV

Dear Editor:

Having read your column in the July edition. I thought you might appreciate some facts concerning TV conditions here in Caracas.

Three TV stations are currently in operation: channel 4, *Televisa*, with about 15 kw of radiated power; channel 5, *Televisora Nacional*; and channel 7, *Radio Caracas-TV*, which is in the process of changing to channel 2. I believe that the radiated power of channels 5 and 7 is lower than that of channel 4.

The scanning rate of all three transmitters is in accord with the power-line frequency of 50 cycles. Using a 625-line scanning system, the horizontal sweep frequency is slightly less than that used in the United States. Most receivers manufactured in the U.S. will function with only slight readjustment of the standard vertical and horizontal controls, with an occasional few requiring resetting of the horizontal-frequency coil.

Some sets, particularly CBS-Columbia, require an additional resistor in the vertical oscillator circuit to obtain proper lock-in. With my 1949 Crosley, I just plugged in the set, adjusted the horizontal-frequency and synchronized the vertical sweep with the front adjustment—that was all.

I mention these facts so that any States-side viewers will be prepared to resync their receiver should they catch a signal from Caracas.

WALTER C. HIEBER, JR.

Caracas, Venezuela

"NO NEW THING"

Dear Editor:

On page 6 of the August issue you inform your readers about "a new departure in electron tube manufacture," describing a ceramic type tube developed by Sylvania.

In 1938 the German Telefunken G.m.b.H. developed and manufactured such tubes for use in German military equipment—especially for decimeter waves. After the last war I had an opportunity to study German military manufacturing techniques and I got hold of a few dozen of these tubes in the *Luftfahrt-forschungsinstitut* at Oberpfaffenhofen near Munich, Bavaria. The mechanical form of these tubes was equivalent to the German "steel" tubes

So, you see, "there is nothing new under the sun."

IVAN I. BEZUGLOFF, JR.

Vice-president, *Metronix, Inc.*
New London, Conn.

A NEW KIND OF BOOK FOR TV SERVICEMEN

by MILTON S. KIVER

"Analyzing and Tracing TV Circuits"



YOU'LL
MASTER
ANY TV
CIRCUIT

the book that gives you all
the knowledge you need and
shows you HOW TO APPLY IT

A BASIC
BOOK

for EXPERTS
or
BEGINNERS

Written by an authority who gives you *all* the facts about every TV circuit and then actually tells you how to apply the knowledge for everyday Service SUCCESS and PROFITS. This book spells out in simple, easy-to-understand language the rules a technician must follow to become top-notch in his work—the rules you need for assured Service SUCCESS. It's the *one "must"* book for every Service Technician.

CONTENTS: Chapt. 1: Things You Should Know About Every Circuit. Chapt. 2: From the General to the Specific. Chapt. 3: Differences Between Schematics and Actual Sets. Chapt. 4: Following the D.C. Power Lines of a Set. Chapt. 5: Where the Boost B+ Fits In. Chapt. 6: The A. G. C. System—From Beginning to End. Chapt. 7: In and Around the Deflection Systems. Chapt. 8: First Things First. Chapt. 9: What To Do When You Meet an Unfamiliar TV Circuit. Chapt. 10: Summary.

168 PAGES, 8½ x 11" \$3.00

ORDER JA-1. Only...

ORDER
TODAY

HOWARD W. SAMS & CO., INC.

Order from your Parts Jobber today, or write to Howard W. Sams & Co., Inc., 2205 East 46th St., Indianapolis 5, Ind.

My (check) (money order) for \$..... enclosed. Send copy(ies) of "Analyzing & Tracing TV Circuits" (JA-1, \$3.00).

Name.....

Address.....

City..... Zone..... State.....

(outside U.S.A. priced slightly higher)

free

1955 VALUE PACKED ALLIED

308-PAGE CATALOG

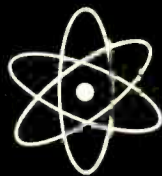

the only COMPLETE
catalog for Everything
in TV, Radio and
Industrial Electronics

SEND FOR IT TODAY

Get ALLIED's 1955 Catalog—308 pages packed with the world's largest selection of quality electronic equipment at lowest, money-saving prices. Select from the latest in High Fidelity systems and components; custom TV chassis, TV antennas and accessories; AM and FM receiving equipment; P.A. Systems and accessories; recorders and supplies; Amateur receivers, transmitters and station gear; specialized industrial electronic equipment; test instruments; builders' kits; huge listings of parts, tubes, tools, books—the world's *most complete* stocks of quality equipment. ALLIED gives you *every* buying advantage: fastest shipment, expert personal help, lowest prices, assured satisfaction. Get the big 1955 ALLIED Catalog. Keep it handy—save time and money on *everything in* Electronics. Send for your FREE copy today.



World's largest Stocks

- All TV and Radio Parts
- All Electron Tube Types
- Test and Lab Instruments
- High Fidelity Equipment
- Custom TV Chassis
- AM, FM Receiving Equipment
- Recorders and Supplies
- P. A. Systems, Accessories
- Amateur Station Gear
- Builders' Kits & Supplies
- Equipment for Industry

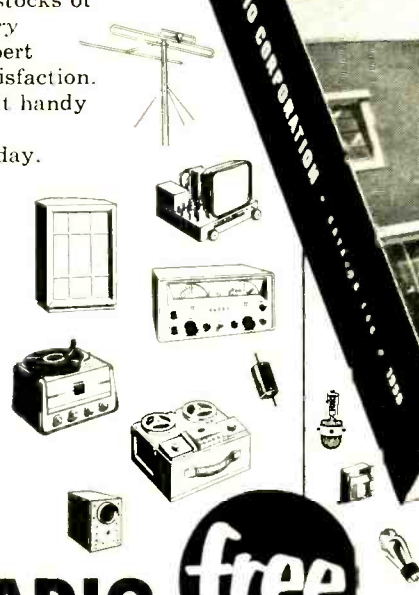

ALLIED RADIO

free

World's Largest Electronic Supply House

EASY-PAY TERMS

Use ALLIED's liberal Easy Payment Plan—only 10% down, 12 months to pay—no carrying charges if you pay in 60 days. Available on Hi-Fi and P. A. units, recorders, TV chassis, test instruments, Amateur gear, etc.

HI-FI SPECIALISTS

To keep up with the latest and best in High Fidelity, look to ALLIED. Count on us for *all* the latest releases and largest stocks of Hi-Fi equipment. We specialize, too, in TV supply—and are foremost in the field of Builders' Kits.

Send for the
leading Electronic
Supply Guide

ALLIED RADIO CORP., Dept. 2-K-4
100 N. Western Ave., Chicago 80, Illinois

Send FREE 308-Page 1955 ALLIED Catalog

Name

Address

City Zone State

ultra-modern facilities for the FASTEST SERVICE IN ELECTRONIC SUPPLY



This
is
CHANNEL
MASTER'S
greatest
antenna
discovery!

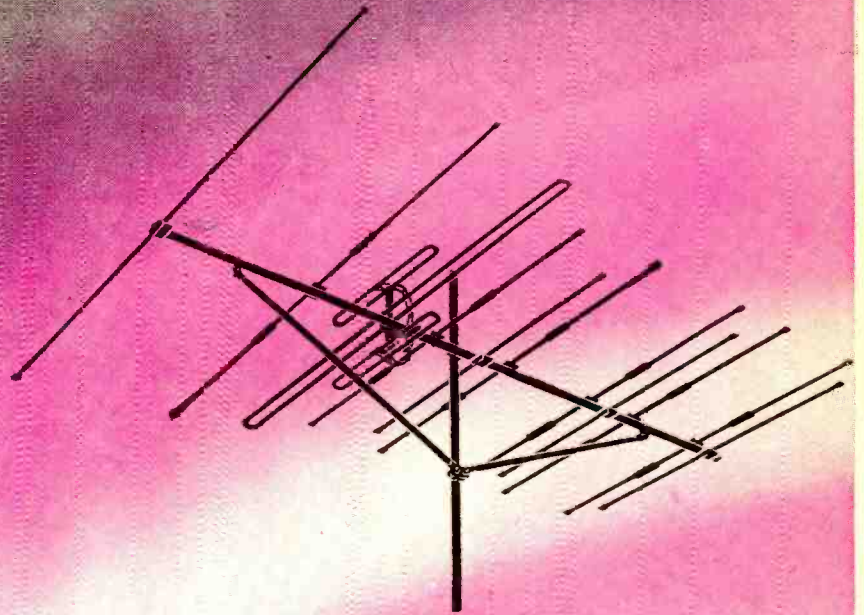

the

RAINBOW*

**the most important antenna
development since the
introduction of the basic Yagi!**

The World's First
Triple-Powered Yagi...

Brilliant all-channel
VHF performance —
and really ready for **COLOR!**

- No other antenna provides such outstanding long distance reception in black and white.
- No other antenna is so well prepared to meet the exacting requirements of color television: Uniform high gain, flat frequency response, extremely narrow polar patterns, highest front-to-back ratios.

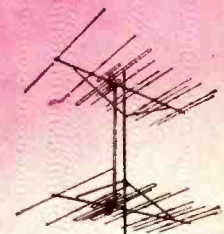

Stacked
SUPER RAINBOW
model no. 331-2

Single bay
SUPER RAINBOW
model no. 331

these 3 basic engineering advances

make the RAINBOW the most powerful all-channel VHF antenna science has yet produced.

- 1. New spacing formula:** Channel Master research has now established new, more efficient relationships between the Yagi's parasitic elements (directors and reflectors) — far greater efficiency than a screen. The radical new spacing arrangement between these elements has, for the first time, extended the full efficiency and high gain of the basic narrow band Yagi over the full width of an entire VHF band.
- 2. New "triple power" High Band directors and reflector:** Three-segment directors and reflectors, with each segment insulated from its adjacent segment, provide the combined power of three High Band Yagis, operating side by side, in perfect phase. This is the first time an entire antenna has been made to operate on the same high gain principle as the fabulous Tri-Pole.
- 3. New "intermix" design:** Combines — into one single antenna — two separate, independent sets of directors and reflectors, one for High Band, one for Low Band. Each parasitic system operates only on its own band. No compromise design. No interaction. No signal loss.

PLUS Channel Master's original, super-gain TRI-POLE . . . the unique triple-powered dipole that made the Champion the most wanted antenna in America.

2 great models available:

RAINBOW, Model No. 330 — for secondary and near-fringe areas.

SUPER RAINBOW, Model No. 331 — for fringe and super-fringe areas.

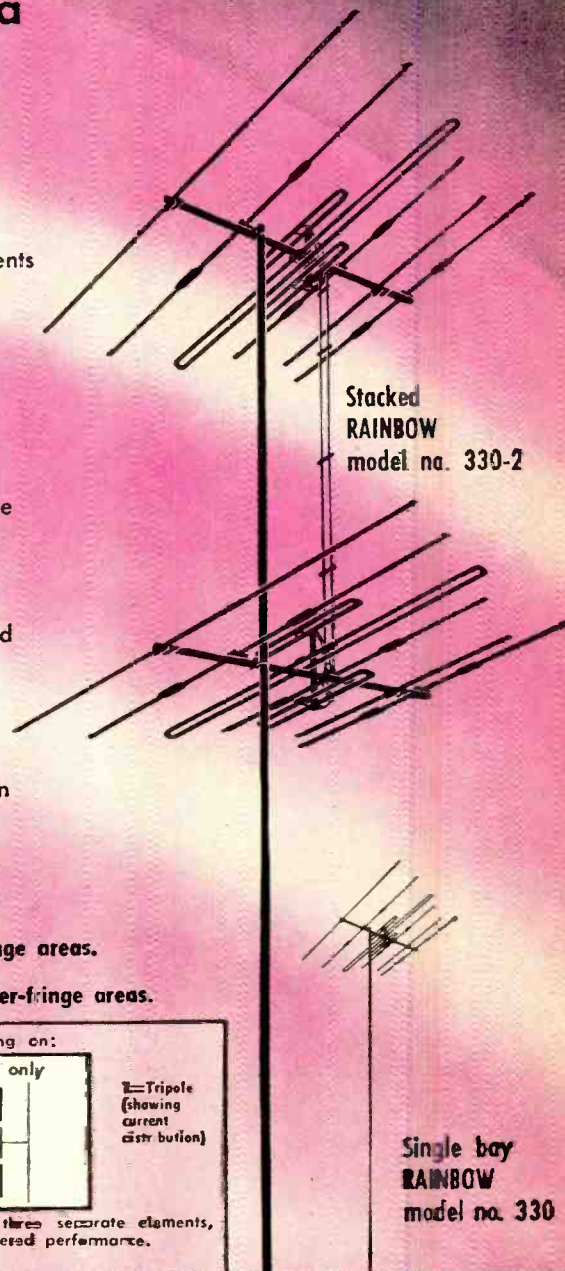

Stacked RAINBOW model no. 330-2

Single bay RAINBOW model no. 330

Full band width — highest gain — of any all-channel antenna.

Diagram illustrates independent operation of the RAINBOW's High Band and Low Band parasitic elements. Note unique new spacing arrangement between elements.

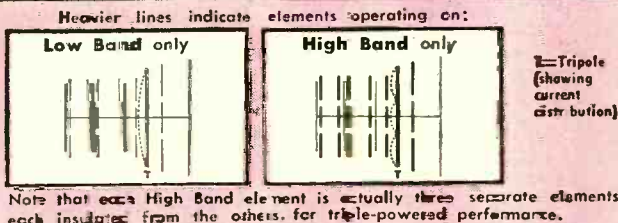

Here's how the RAINBOW out-performs the famous Champion.

		CHANNEL	2	3	4	5	6	7	8	9	10	11	12	13
Gain Over 1-Bay Champion	1-Bay RAINBOW	0	0	0	+1	+2	+3	+2.5	+1	+5	+2	+1.5	+2.5	
	1-Bay SUPER RAINBOW	+1	+1	+1.5	+2.5	+3.5	+3.5	+3	+2	+1.5	+2	+3.5	+4.5	
Gain Over Stacked Champion	Stacked RAINBOW	+1.5	+2	+1.5	+1.5	+2	+3	+3	+3	+0	+0	+0	+1	+1.5
	Stacked SUPER RAINBOW	+2	+2.5	+3	+3	+4	+5	+1	+1	+2	+2	+2.5	+3.5	

Horizontal Polar Pattern (relative voltage)

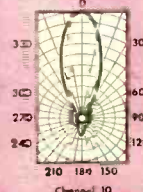

Seen in October



CHANNEL MASTER CORP.
ELLENVILLE, N. Y.

THE WORLD'S LARGEST MANUFACTURER OF TV ANTENNAS

Write for complete technical literature

YOU be the Judge!

Let the Kay-Townes SUPER-KATY
prove its superiority over
ALL other TV antennas
on the market today!



Here's why the famous
KAY-TOWNES

Super **KATY**

wins in every case!

- FAR REACHING Reception!
- New MOLDED, RIBBED INSULATOR for low water absorption!
- New RIGID Construction to withstand gale-force winds!
- EASY Installation!
- LESS DEPTH on mast!
- Best by Color-Test!
Super Katy has been proved the best antenna for fine color reception by actual field tests.

Every Super Katy installed
will bring **NEW SALES!**

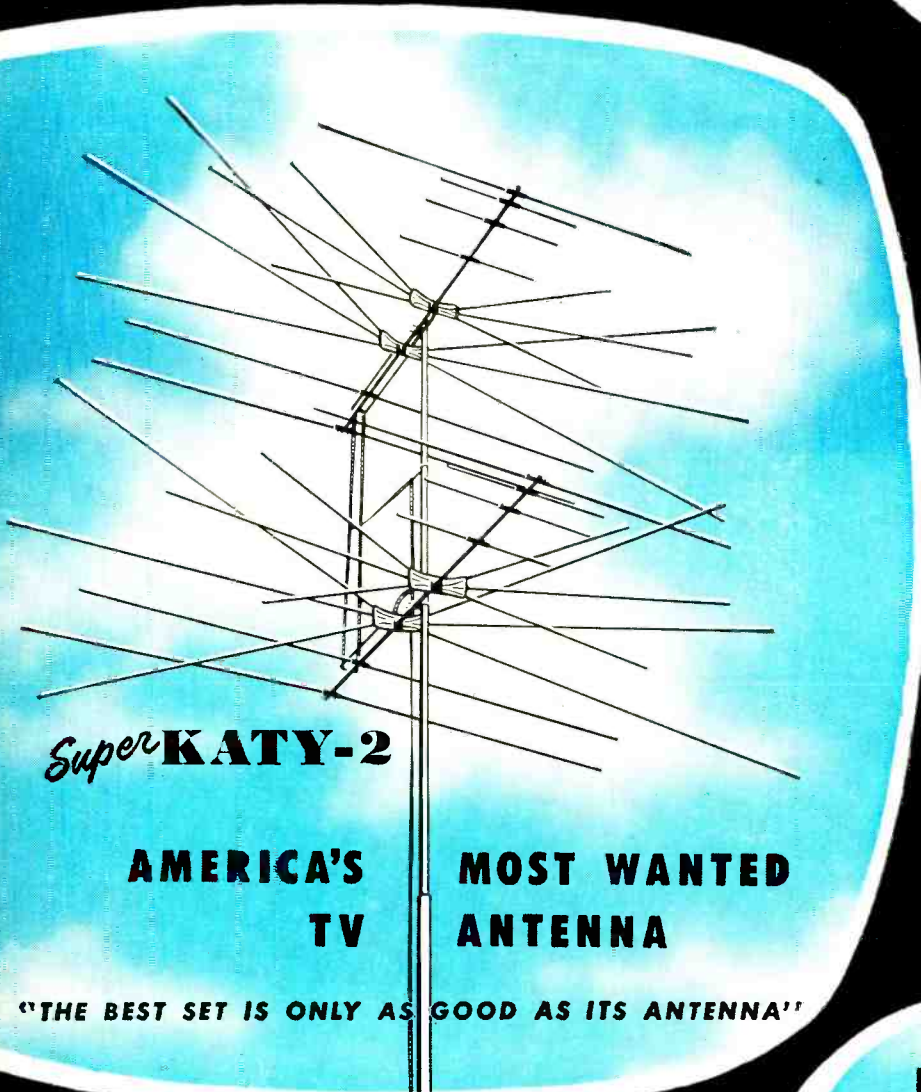

Super **KATY-2**

**AMERICA'S MOST WANTED
TV ANTENNA**

"THE BEST SET IS ONLY AS GOOD AS ITS ANTENNA"

The long reach, long profit antenna

"Fringe area" dealer-servicemen in every part of the country are reporting outstanding sales and service stories . . . and, mounting TV consumer demand! The new, revolutionary Super "KATYS" have now convincingly proved every quality and performance claim attributed to them.

Kay-Townes' original SUPER KATY design . . . now amazingly improved . . . will out-perform any other competitive antenna on the market today, regardless of type or design principle!

Manufactured and Distributed in CANADA By
DELHI METAL PRODUCTS, LTD., DELHI, ONTARIO

**KAY-TOWNES
ANTENNA CO.**
ROME • GEORGIA

Originators of
the **BIG-JACK**
the world's most Copied TV Antenna

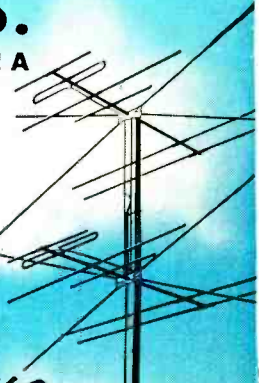

Write your own ticket



L. C. Lane, B.S., M.A.
President, Radio-Television Training Association. Executive Director, Pierce School of Radio & Television.

Use your experience in radio to step into a higher paying television job by studying AT HOME in your SPARE TIME.

The fabulous television industry has seen many booms — in building of broadcasting stations, manufacture of black and white VHF sets, and sale of these sets to millions of families — but the biggest booms are yet to come.

From my experience in the radio-television-electronics field and my contacts in high places, I can tell you that past TV booms will look small compared to the booms that will come with construction of new VHF and UHF stations and perfection of low-cost color television sets.

These developments are just around the corner. If YOU want to be in on the ground floor for the jobs that will be created, now is the time to do it. You can keep your present job and study one of my two NEW courses — FM and Television Technician Course — TV Cameraman and Studio Course.

These Courses — especially prepared for home study — will train you for top-paying jobs in the ever-expanding radio-television-electronics industry. You'll be able to write your own ticket to get a better pay job or set up your own business.

EXPERT FM-TV TECHNICAL TRAINING

My FM-TV Technician Course lets you take full advantage of your previous experience — either civilian or Armed Forces. YOU CAN SAVE MONTHS OF TIME. My FM-TV Technician Course completes your training by providing a thorough background in Frequency Modulation and Television Theory and Practice.

You "Learn by Doing", working with parts and equipment I send you. Six large kits of FM and TV parts are given to you as part of the course. You build and keep a professional GIANT SCREEN TV RECEIVER complete with big picture tube (designed and engineered to take any size up to 21-inch).

Upon completion of your training you may — if you desire — take two weeks of shop training at my associate resident school in New York City AT NO EXTRA COST!



PRACTICAL TV CAMERAMAN AND STUDIO COURSE

My TV Cameraman and Studio Course is designed to train TV Studio Technicians and TV Cameramen, urgently needed today by Television Broadcasting Stations throughout the nation.

New TV Stations are now mushrooming throughout the country. Men who can work as Audio Technicians, TV Cameramen, Microphone Boom Operators, Monitor

Operators, Turntable Operators, Control Room Technicians can write their own tickets.

I will train you for an exciting high pay job as the man behind the TV camera. Work with TV stars in TV studios or "on location" at remote pick-ups.

Available if you want it . . . one week of actual work with studio equipment & TV Cameras at my associate resident school in New York City.

This course is a MUST for those who wish to increase their technical knowledge of television operations.

TRAINING FOR BEGINNERS

My Radio-FM-Television Technician Course is especially prepared for men with no previous experience or training. I have trained hundreds of men for successful careers in radio-television-electronics. Many of them had only a grammar school education and no previous experience whatsoever in the field.

Two weeks of intensive shop practice at my associate resident school is also included with this Course.

Radio Television Training Association

52 EAST 19th STREET • NEW YORK 3, N. Y.

Licensed by the State of New York • Approved for Veteran Training

OCTOBER, 1954



VETERANS!

My School fully approved to train veterans under new Korean G.I. Bill. Available only to Veterans discharged after June 27, 1950. If eligible, CHECK COUPON.

FREE FCC COACHING COURSE

Important for BETTER PAY JOBS requiring FCC license. You get this training AT HOME and AT NO EXTRA COST. Top TV jobs go to FCC-licensed technicians.

EARN while you LEARN

Almost from the very start you can earn extra money while learning, repairing Radio-TV sets for friends and neighbors. Many of my students earn up to \$25 a week . . . pay for their entire training from spare time earnings . . . start their own profitable service business.



MAIL THIS COUPON TODAY!
NO SALESMAN WILL CALL!

Mr. Leonard C. Lane, President
RADIO-TELEVISION TRAINING ASSOCIATION
52 East 19th Street, New York 3, N. Y. Dept. R-10

Dear Mr. Lane: Mail me your NEW FREE BOOK, FREE SAMPLE LESSON, and FREE aids that will show me how I can make BIG MONEY IN TELEVISION. I understand I am under no obligation and no salesman will call.
(PLEASE PRINT PLAINLY)

Name _____ Age _____
Address _____
City _____ Zone _____ State _____

I AM INTERESTED IN:
 Radio-FM-TV Technician Course
 FM-TV Technician Course
 TV Cameraman & Studio Technician Course
VETERANS? Check here for Training under NEW G.I. Bill.

precise

says:

Ask ANY Engineer, "WHAT'S THE TOUGHEST TEST OF ALL?"

YOUR test . . . the way the equipment works in actual use . . . under actual conditions. PRECISE test equipment has passed that test countless times . . . every instrument fully proven. That is why YOU and thousands like you have made PRECISE the fastest growing line of test instruments in America today!

Remember, too, PRECISE uses no surplus. See the complete line of PRECISE quality instruments at your jobber now—and save!

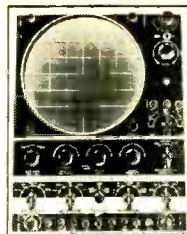

EXCLUSIVE PRECISE 8½" OSCILLOSCOPE
#308K kit form \$129.50
#308W factory wired \$229.50

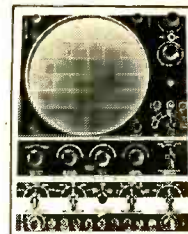

PRECISE 7" OSCILLOSCOPE
#300K kit form \$94.95
#300W factory wired \$199.50

precise ★ precise ★ precise ★ precise



EXCLUSIVE PRECISE VOLT. REG. V.T.V.M.
#9071K kit form \$35.95
#9071W factory wired \$49.95



NEW PRECISE VOLTAGE REG. POWER SUPPLY
#760K kit form \$39.95
#760W factory wired \$59.95

★ precise ★ precise ★ precise ★

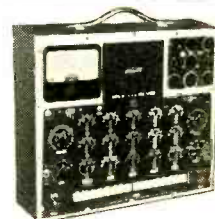

NEW PRECISE Em. & MUT. COND. TUBE TESTER
#111K kit form \$69.95
#111W factory wired \$139.95

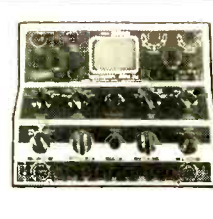

NEW PRECISE 3" PORTABLE OSCILLOSCOPE
#303K kit form
#303W factory wired

se ★ precise ★ precise ★ precise ★ precise ★ precise ★ precise



LOWEST PRICED

PRECISE RESISTANCE DECADE BOX
#468K kit form \$18.95
#468W factory wired \$24.95



PRECISE RF-AF-TV & MARKER GENERATOR
#630K kit form \$33.95
#630KA pre-assembled head \$38.95
#630W factory wired \$53.95



PRECISE RF SIGNAL GENERATOR
#610K kit form \$23.95
#610KA pre-assembled head \$28.95
#610W factory wired \$39.95



NEW PRECISE VACUUM TUBE VOLTMETER
#909K kit form \$25.98
#909W factory wired \$37.50

★ precise ★ precise ★ precise ★ precise ★ precise ★ precise ★ precise

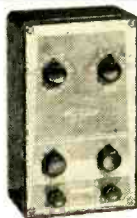

LOWEST PRICED

PRECISE CAPACITY DECADE BOX
#478K kit form \$18.95
#478W factory wired \$24.95



PRECISE RF PROBE
#912 wired only \$4.25
PRECISE CAPACITY ATTENUATOR PROBE
#960 wired only \$5.95

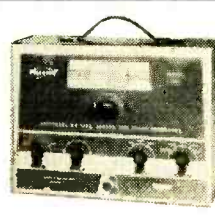

PRECISE UNIV. AF SINE, SQ. & PULSE GEN.
#635K kit form \$33.50
#635W factory wired \$52.50

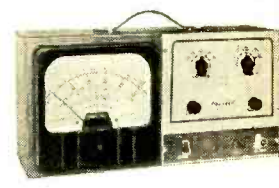

PRECISE DELUXE VACUUM TUBE VOLTMETER
#907K kit form \$38.98
#907W factory wired \$57.98

cise ★ precise ★ precise ★ precise ★ precise

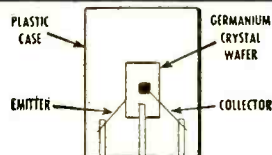

PRECISE NEW T1 TRANSISTOR KIT

PRECISE offers a simple and direct approach to the understanding of transistors. The instruction book covers the physics and practical applications in simple and non-mathematical terms. Two transistors, one germanium diode, transformer, electrolytics, coils, resistors, condensers, chassis, etc. are supplied.
Model T1

kit only \$17.95



PRECISE HIGH VOLTAGE PROBE
#999 wired only \$6.98

precise

DEVELOPMENT CORP.
OCEANSIDE, NEW YORK

Prices slightly higher in the West. Prices and specifications subject to change without notice.

SEND FOR NEWEST PRECISE CATALOG—DEPT. MB-1

Home Study Courses in TELEVISION SERVICING offered by RCA INSTITUTES



Study Television Servicing—from the very source of the latest, up-to-the-minute TV and Color TV developments. Train under the direction of men who are experts in this field. Take advantage of this opportunity to place yourself on the road to success in television. RCA Institutes, Inc. (A Service of Radio Corporation of America), thoroughly trains you in the "why" as well as the "how" of servicing television receivers.

FIRST HOME STUDY COURSE IN COLOR TV SERVICING

Now you can train yourself to take advantage of the big future in Color TV. RCA Institutes Home Study Course covers all phases of Color TV Servicing. It is a practical down-to-earth course in basic color theory as well as how-to-do-it servicing techniques.

This color television course was planned and developed through the combined efforts of instructors of RCA Institutes, engineers of RCA Laboratories, and training specialists of RCA Service Company. You get the benefit of years of RCA research and development in color television.

Because of its highly specialized nature, this course is offered only to those already experienced in radio-television servicing. Color TV Servicing will open the door to the big opportunity you've always hoped for. Find out how easy it is to cash in on Color TV. *Mail coupon today.*

SEND FOR FREE BOOKLET

Mail coupon in envelope or paste on postal card. Check course you are interested in. We will send you a booklet that gives you complete information. No salesman will call.



RCA INSTITUTES, INC.
A SERVICE OF RADIO CORPORATION OF AMERICA
350 WEST FOURTH STREET, NEW YORK 14, N.Y.

HOME STUDY COURSE IN BLACK-AND-WHITE TV SERVICING

Thousands of men in the radio-electronics industry have successfully trained themselves as qualified specialists for a good job or a business of their own—servicing television receivers. You can do this too.

This RCA Institutes TV Servicing course gives you up-to-the-minute training and information on the very latest developments in black-and-white television.

As you study at home, in your spare time, you progress rapidly. Hundreds of pictures and diagrams, easy-to-understand lessons help you to quickly become a qualified TV serviceman.

There are ample opportunities in TV, for radio servicemen who have expert training. Mail coupon today. Start on the road to success in TV Servicing.

MAIL COUPON NOW

RCA INSTITUTES, INC.
Home Study Dept. RE-1054
350 West Fourth Street, New York 14, N. Y.
Without obligation on my part, please send me copy of booklet on:

- Home Study Course in TELEVISION SERVICING.
 Home Study Course in COLOR TV SERVICING.

Name _____
(please print)

Address _____

City _____ Zone _____ State _____



THE 980 LINE



Model 985 Calibrator—\$199.50



Model 983 Oscilloscope—\$329.50



Model 984 Sweep Generator—\$199.50



Model 982 Vacuum Tube Voltmeter—\$69.50

Representing an entirely new approach in test equipment design and operation, the 980 Line instruments have brought new *simplicity* and new *time-saving facility* to TV receiver alignment and servicing. Now available to TV technicians through leading distributors. Literature giving complete information on request. WESTON Electrical Instrument Corporation, 614 Frelinghuysen Avenue, Newark 5, N. J.

8420



TEST EQUIPMENT

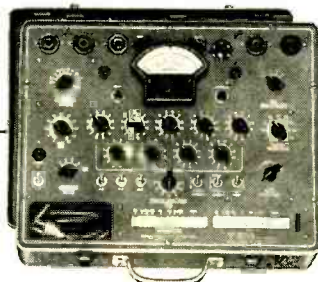

Model 981 Tubechecker—\$199.50



Model 980 Analyzer—\$52.50

Where do you find
PYRAMID
Capacitors?

As original components
in TV sets
bearing these famous
brand names ▶



Arvin

DU MONT

ZENITH

RAYTHEON

Emerson

Motorola

SYLVANIA

Packard-Bell

hallicrafters

Westinghouse

Hoffman



And at your parts distributor in this self-service dispenser—here are 93% of all the capacitors you use every day in TV service—make a quick check while you're waiting for your order—the time you save by keeping an adequate stock is the time you make your extra profit.

 **PYRAMID ELECTRIC CO.**

1445 Hudson Blvd. • North Bergen, N. J.

CO-TRAP gives highest FRONT TO BACK RATIO of 5 major competitors!

introducing the all channel **SKYLINE IMPERIAL** with Co-Trap

AMAZING FRONT TO BACK RATIO TEST DATA

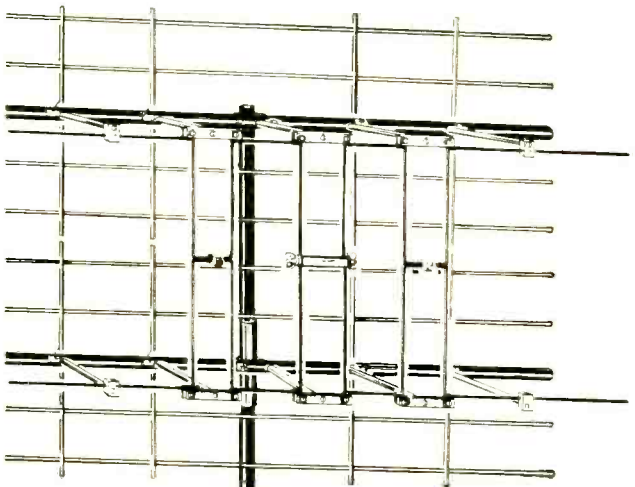

Patented

FREQUENCY (Megacycles)	RELATIVE VOLTAGE	
	2-bay Model 701 (Without "Co-Trap" Screen)	Skyline Imperial Model 701-CT (With "Co-Trap" Screen)
50	9.12	10.1
60	9.4	18.1
70	9.4	14.
80	6.8	14.8
90	7.4	14.8
170	3.5	12.9
180	5.1	14.
190	6.4	21.9
200	4.1	16.9
210	4.1	14.
216	3.5	20.

Independently tested by the Research Division of Mark Products Co. of Chicago, Edward F. Harris, Chief Engineer.

CHARACTERISTIC VHF BAND PATTERNS with "Co-Trap"



Channel 9

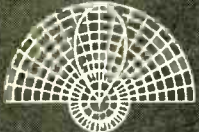

Channel 4

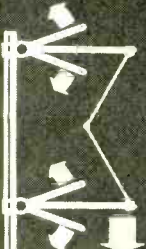

UNFOLD—
TIGHTEN

3000 WITNESSES AT GRAND DEBUT WATCH THE "IMPERIAL" OUTPERFORM 4 MAJOR COMPETITORS!

Side-by-side comparison test proves "Imperial" far superior at rejecting co-channel interference!

Two competitors failed completely—pictures entirely blotted out.

Another two showed inferior pictures and much interference.

Coming through with flying colors, the "Imperial" gave a clear picture free of interference.

Full size 5000 square inch screen.

All aluminum—extra heavy throughout.

Completely pre-assembled.

MODEL No. 701-CT (2-bay, with "Co-Trap" screen) ———> **\$27.50**

MODEL No. 700-CT (4-bay, with "Co-Trap" screen) also available—\$57 list

LIST

Packed 2 per carton

SKYLINE MFG. CO. 1652 Rockwell Ave., Cleveland 14, Ohio

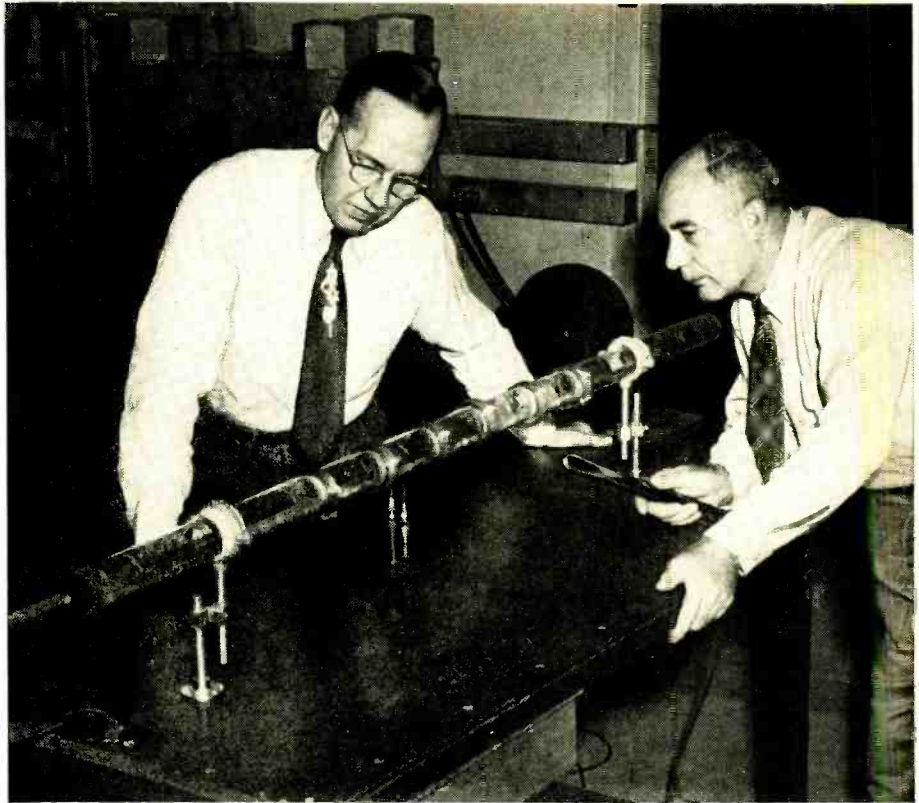

Zone Refining apparatus, showing tube and induction-heating coils. For transistors—tiny electronic amplifiers—germanium is made extremely pure. Then special impurities are added in controlled amounts for best transistor performance.

1 part in 10,000,000,000

To make the most of their revolutionary invention, the transistor, Bell Laboratories scientists needed ultra-pure germanium.

The scientists solved their problem by devising a radically new refining process. The germanium it yields may well be the purest commercially produced material on earth.

It has only *one part in ten billion* of impurities harmful to transistor performance. That's about the same as a pinch of salt in 35 freight cars of sugar.

Yet the new process, Zone Refining, is simple in principle. An ingot

of germanium is drawn through a series of induction-heating coils that melt narrow zones of the substance. Since impurities are more soluble in the liquid than in the solid form of a metal, the molten zones collect impurities. They are swept along by the successive melts to the end of the ingot, which is finally cut off.

Zone Refining is also being applied to the ultra-purification of other materials useful to telephony. This single achievement of research at Bell Telephone Laboratories clears the way for many advances in America's telephone system.

BELL TELEPHONE LABORATORIES

IMPROVING AMERICA'S TELEPHONE SERVICE PROVIDES CAREERS
FOR CREATIVE MEN IN SCIENTIFIC AND TECHNICAL FIELDS



NOW... 2 SENSATIONAL EICO SCOPE VALUES!

NEW AMAZING FEATURE PACKED
7" PUSH-PULL OSCILLOSCOPE

Only EICO Has All These Features

- VERTICAL FREQ. RESPONSE: flat ± 2 db 10 cps - 1 mc
- VERTICAL SENS.: .01 volts rms/inch
- HOR. FREQ. RESP.: flat ± 0 db 10 cps - 200 kc, -4 db at 500 kc
- HOR. SENS.: .3 volts rms/inch
- SWEEP RANGE: 15 cps-100 kc
- 3-STEP FREQ.-COMPENSATED ATTENUATOR eliminates freq. distortion, overloading.
- CATHODE FOLLOWER inputs to both amplifiers
- PUSH-PULL outputs in both amplifiers
- RETURN TRACE BLANKING
- INT. VOLTAGE CALIBRATOR
- V & H TRACE EXPANSION & CENTERING: 1.5X full screen without distortion.
- DIRECT CONNECTION to vert. CRT plates
- PHASING CONTROL of internal 60 cps sine wave sweep.
- AT FRONT PANEL: intensity mod. Input; 60 cps, sawtooth outputs.



MODEL 470K
KIT \$79.95. WIRED \$129.50.

EICO EXCLUSIVE! 5" PUSH-PULL SCOPE, 425K,
Amazing feature-packed economy-priced
Wired, \$79.95. KIT, \$44.95.

- PUSH-PULL V & H amplifiers. Sens: 0.5-1 rms v/in. Dual trace to 2.5 mc.
- SWEEP: 15 cps-76 kc. 2-axis intensity modulation. Dual trace positioning controls.



SCOPE VOLTAGE CALIBRATOR KIT
495K KIT \$12.95. WIRED \$17.95.

- Sq. wave output at power-line freq. with full-scale readings of 1, 1, 10 or 100 V. peak-to-peak
- Accuracy $\pm 5\%$ of full-scale on each range.

6V & 12V BATTERY ELIMINATOR KIT
1050K KIT \$29.95. WIRED \$38.95.

- DC output: 0-8 V or 0-16 V.
- Continuous current ratings: 10 A at 6 V, 6 A at 12 V.
- Intermittent current rating: 20 A at 6 V, 12 A at 12 V.
- Separate Voltmeter & Ammeter.



221K VTVM KIT \$25.95. WIRED \$39.95.

- AC/DC volts: 0-5, 10, 100, 500, 1000 (30 kv with HVP probe)
- Res.: 0.2 ohms-1000 megs, 5 ranges
- DC input R: 25 megs
- 4 1/2" meter in can't burn out circuit
- 1% mult. resistors
- HIGH VOLTAGE PROBE \$4.95
- Extends range of VTVMs & voltmeters to 30 kv.



630K CATHODE RAY TUBE CHECKER
KIT \$17.95. WIRED \$24.95



- Checks all types of TV picture and C.R. tubes in the set or carton. Bridge measurement of peak beam current (proportional to screen brightness).
- Detects shorted & open elements

625K TUBE TESTER KIT \$34.95. WIRED \$49.95.



- Illum. gear-driven "Speed Rollchart."
- New lever-action switches for individual testing of every element.
- Tests all conventional & TV tubes.
- PIX TUBE ADAPTER for Tube Testers \$4.50. Checks TV picture tubes while in set.

360K SWEEP GEN. KIT \$34.95. WIRED \$49.95.

- Continuous coverage of all TV & FM freqs. from 500 kc to 228 mc.
- Sweep width variable 0-30 mc.
- Crystal marker oscillator, variable amplitude.



214K VTVM KIT \$34.95. WIRED \$54.95.



- Large 7 1/2" meter, can't burn-out circuit.
- AC/DC volts: 0-5, 10, 100, 500, 1000 (30 KV with HV Probe).
- 5 ohms ranges from .2 ohm to 1000 megs.
- DC input R: 25 megs.
- 1% mult. resistors

Large 7 1/2" meter.

950B-K R-C BRIDGE & R-C-L COMP. KIT \$19.95.
WIRED \$29.95.

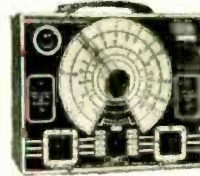

- Measures & tests all resistors; .5 ohm to 500 megohms.
- Every type condenser, 10 mmf to 5000 mid.
- 0-500 DC voltage source for capacitor leakage testing.

352K BAR GENERATOR KIT \$14.95
WIRED \$19.95

- Reliable, accurate, portable, easy-to-use.
- Operates on channels 2-6. 16-23 vert. bars to check M linearity. 13-22 hor. bars to check V linearity.
- Shows pic size & V & H sync circuit stability.
- Entirely independent of station sent signals.



Prices 5% higher on West Coast. Specifications and prices subject to change without notice.

NOW! ONLY **TEICO** KITS
& WIRED INSTRUMENTS Gives You
LIFETIME SERVICE &
CALIBRATION GUARANTEE*
*at less than our cost of handling (See EICO Guarantee Card enclosed with each Kit & Instrument).

315K DELUXE SIG. GEN. KIT \$39.95. WIRED \$59.95.



- Covers range of 75 kc to 150 mc.
- 7 calibrated scales: accuracy better than 1%.
- Bandsread vernier tuning.
- 4-step RF shielded output multiplier: constant output Z.

377K SINE & SQUARE WAVE AUDIO
GEN. KIT \$31.95. WIRED \$49.95.



- Complete sine wave coverage, 20-200,000 cps in 4 direct-reading ranges.
- Complete square wave coverage, 60-50,000 cps.
- Cathode follower output circuit.

536K MULTIMETER KIT \$12.90. WIRED \$14.90.
528K MULTIMETER KIT \$13.90. WIRED \$16.90.



- 1000 Ω /V; 31 ranges
- DC/AC volts: Zero to 1, 5, 10, 50, 100, 500, 5000.
- DC/AC Current: 0-1, 10 ma; 0.1, 1 A.
- Ohms: 0-500, 100 K, 1 meg.

565K MULTIMETER KIT \$24.95 WIRED \$29.95.



- 555K MULTIMETER KIT \$29.95
WIRED \$34.95.
(1% precision resistors)
- 20,000 Ω /V; 31 ranges.
 - DC/AC/Output volts: 0-2.5, 10, 50, 250, 1000, 5000.
 - DC Current: 0-100 μ a; 10, 100, 500 ma; 10 A.
 - Ohms: 0-2K, 200K, 20 meg.

145K SIG. TRACER KIT \$19.95.
WIRED \$28.95.



- Audibly signal traces all IF, RF, Video & Audio circuits from ANT to SPKR or CRT in all TV, FM, AM, etc. without switching.
- Germanium crystal diode probe responsive to over 200 mc.
- Integral test speaker.

320K SIG. GEN. KIT \$19.95. WIRED \$29.95



- Vernier tuning condenser.
- Stable Hartley RF osc., range: 150 kc to 34 mc, calibrated harmonics to 102 mc.
- Pure or modulated RF, & Colpitts oscillator 400 cps sine wave outputs.
- 322K SIG. GEN. KIT \$23.95. WIRED \$34.95.
(As above, plus individual calibration of each of its 5 bands)

Write Now for FREE latest Catalog C-10

New! EICO SCOOPS!

232K PEAK-to-PEAK VTVM
with DUAL-PURPOSE AC/DC *Uni-Probe*
KIT \$29.95 WIRED \$49.95



Measures directly p-p voltage of complex and sine waves: 0-4, 14, 42, 140, 420, 1400, 4200 V DC/RMS. Sine voltage range: 0-1.5, 5, 15, 50, 150, 500, 1500 V. Ohms: 0-1000 megs. 7 non-skip ranges on every function. Calibration without removing from cabinet. Zero center. Freq. Resp. 30 cps-3mc. 1% precision ceramic multipliers. Exceptional stability and accuracy. Compact, portable (8 1/2 x 5 x 5"), smart, rugged.

NEW! UNI-PROBE! Terrific time-saver! Only 1 probe for all functions—a half-turn of probe-tip selects DC or AC (Peak-to-Peak or RMS)/OHMS!

249K PEAK-to-PEAK VTVM with 7 1/2" METER KIT \$39.95 WIRED \$59.95-

944K FLYBACK TRANSFORMER AND YOKE TESTER
KIT \$23.95 WIRED \$34.95

Tests all flybacks and yokes, in or out of TV set—in just seconds! Detects even 1 shorted turn!

Exclusive separate calibration for air—and iron-core flybacks assures utmost accuracy. Large 4 1/2" meter, 3 colored scales. Compact, portable (8 1/2 x 5 x 5"), smart, rugged.

488K ELECTRONIC SWITCH KIT \$23.95. WIRED \$39.95
1171K DECADE RESISTANCE BOX KIT \$19.95. WIRED \$24.95
1180K DECADE CONDENSER BOX KIT \$14.95. WIRED \$19.95



Separate Assembly & Operating Manuals supplied with each EICO KIT!

You build EICO Kits in one evening, but... they last a lifetime!

SAVE OVER 50%! See the famous EICO line TODAY, at your local jobber.

ELECTRONIC INSTRUMENT CO., Inc. 84 Withers Street, Brooklyn 11, N.Y.

SERVICE INSURANCE

. . . . Can the Public insure itself against set failure?

THE idea of radio or television receiver service insurance is not new. It has been offered in many disguises in the past in the U.S. and abroad.

Briefly—in its simplest aspect—the set owner pays a periodic fee to the “insurer,” who then repairs the receiver “free” for a certain period. The insurer’s experience is that not every set goes out of order. Thus he can gamble—as in most forms of insurance—that a certain percentage of receivers per year need not be serviced. The insured, by paying his fee, in turn knows that, if his set fails, it will be repaired during the period for which it is insured.

This type of plan differs from a standard television contract service—which has been called a form of insurance in some areas—in that the tendency of TV contract organizations has been to concentrate on new receivers and on receivers handled by the organization or by dealers with whom it has a contract, rather than to advertise or canvass for contracts on older receivers of any make. The chief and most important difference, though, is that the fees or “membership dues” proposed by these insurance plans are invariably far lower than the cost of the conventional television service contract.

How does such a plan benefit the public? It all depends upon the insurance plan or contract. It can be good, poor, or downright bad. In business and in insurance, no sane organization ever gives away anything for nothing. At best, you get what you pay for!

Let us look now at one of the radio and TV insurance plans which has been in vogue for some time in Chicago, Milwaukee, and lately in Toronto, Canada.

The following is quoted verbatim from a half-page advertisement recently printed in the *Toronto Star*, a prominent Toronto newspaper:

Our Rates—Your TV set service and repaired in your home. (Complete for labor) . . . \$1.95. Major repair job, necessitating service in our shop, including pickup and delivery (Complete for labor) . . . \$4.95. Free inspection of your set before warranty is issued. 20% discount on all parts—or free if you have parts warranty. Phono-radio service included if your set is a combination. (Signed): *Authorized T.V. Service Clubs*, 2929 Dufferin Street, Toronto, Ontario.

(The difference between the \$1.95 and \$4.95 prices and the “No Charge” in different parts of the ad is that the first job is handled free.)

Similar ads have appeared in a number of metropolitan centers for several years. The plan would not work out as well in smaller communities for the simple reason that the quantity of customers would be unprofitable for a large-scale operation.

In the large cities, however, the situation is different and can be very profitable to the insurance organization. *Indeed, it can get most of its operating capital simply by advertising.* One thousand customers thus will pay \$12,500 a year—not a bad start for a comparatively small investment in one or two newspaper ads.

If the service insurance company is scrupulously honest, if the insurance funds collected from the public are safeguarded by state supervision, if its service technicians are able and honest, such a plan cannot be criticised in the least. Unfortunately, in the past, similarly conducted service enterprises have gone bankrupt in various parts of the country, losing hundreds of thousands of dollars of the public’s money.

It is a fact, too, that the temptation to the service insurance company to overcharge the set owner—even for minor repairs—is always very great. In many cases the public is made to pay for the insurance plus unreasonable charges for parts when

Here's What You'd Normally Pay Without Membership	What You Pay as a Member	Major Repair Job Necessitating shop service, including pickup and delivery and labor. (Without membership)	Major Repair Job Necessitating shop service, including pickup and delivery and labor. (With membership)
Home Service Call	Home Service Call	You Pay \$15.00	You Pay No Charge
You Pay \$4.50	You Pay No Charge	Plus parts at suggested list price of manufacturer.	20% Discount on parts from suggested list price of manufacturer.
Plus parts at suggested list price of manufacturer.	(Average) \$3.75	(Average) \$20.00	(Average) \$20.00
(Average) \$3.75	less 20% \$3.00	Total (Average) \$35.00	less 20% \$16.00
Total (Average) \$8.25	Total (Average) \$3.00	Total (Average) \$35.00	Total (Average) \$16.00
	No Charge if no parts required		No Charge if no parts required

TV OUT OF ORDER? If you join our club now . . . **WE'LL REPAIR IT FREE!** Absolutely no charge for either house call or shop labor, with a 20% discount on parts (from manufacturer’s suggested list price). No charge for parts if TV set is under parts warranty. We want to acquaint you with the service plan that is already saving thousands of members from costly repairs.

NOTE! If your television set is operating to your satisfaction now, you can still take advantage of our offer by enrolling now . . . and whenever your TV set does need service or repair within one year, your first repair job will be free!

How It Works. Based on the theory that television repair costs and profits are too high—Authorized TV Service Clubs have organized a plan whereby TV repair costs are reduced to a fraction. Through large membership and economical routing of trucks and men, its small operating cost—and its small net profit based on large volume—Authorized TV Service Clubs can afford to give you expert, guaranteed TV Service at these low cost prices.

Experienced and Bonded. Our service men are thoroughly experienced and trustworthy. Our modern shops contain the latest in scientific equipment. We have a fleet of trucks and an ample supply of parts. On every count Authorized TV Service Clubs is well prepared to serve you . . . and serve you well. Within 24-hour service in Metropolitan Toronto.

Only \$12.50 to join. Includes 1-year membership—all benefits.

not needed at all.

All too frequently the set owner finds that his “insurance” is worthless and that he would have been better off if he had not had any to begin with.

It seems to us that, if the service insurance companies are working for the best interest of the customer, they should take a number of important steps, which, incidentally, would benefit them as much as their customers. These are:

1. All insurance funds to be state-regulated or placed in a trust fund under bank, city or state regulation.
2. All service technicians in the employ of the service insurance companies to be bonded.
3. Written itemized receipts to be issued in repairing a given receiver.
4. All defective parts taken from repaired set to be returned to customer.

Such a program would give the customer greater confidence in the servicing insurance organization. In turn, the latter could use it to excellent advantage in its advertisements and literature.

However, we seriously doubt if any of the newer service insurance organizations will ever make use of the four-point plan outlined above. It is far more profitable to work without such handicaps. That is, unless the activities of these organizations assume large proportions all over the land.

Then, as has happened in parallel enterprises, the state or the Federal Government will regulate their activities in any event.

H.G.

TEST INSTRUMENTS

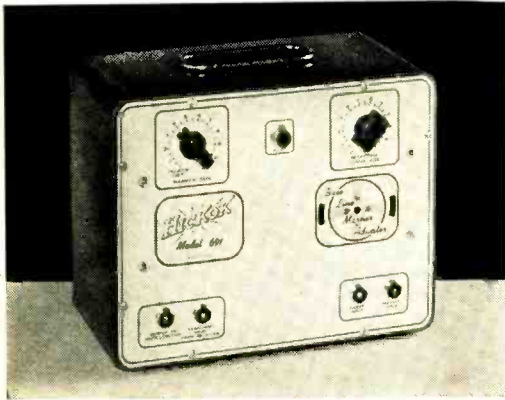

The Hickock model 691 marker adder.

Specialized equipment widens usefulness of your scope or v. t. v. m; makes servicing easier and faster

NEW INSTRUMENTS for TV SERVICING



The HF3 probe and video amplifier.

by **ROBERT F. SCOTT**
TECHNICAL EDITOR

THIS magazine has published a number of articles describing specialized scope and v.t.v.m. test probes for use where circuit resonances and waveforms are critical and where very high impedances and complex high-amplitude voltages are encountered. One of the most common specialized probes is the frequency-compensated type (Fig. 1) used to prevent distortion of TV signals tapped off high-impedance points and fed to the input of an oscilloscope. The unit consists of two parallel-connected R-C networks in series across the signal source with the output signal tapped off at the junction of the R-C networks. Distortion is minimum when R_1-C_1 equals R_2-C_2 .

The tip and body of the probe are shielded to minimize pickup of hum and stray signal voltages. Although the shield is designed for optimum performance, it adds to the stray input capacitance C_s and brings the total value to 10–15 μf . This capacitance greatly attenuates the signal (20 db or higher) and often is high enough to detune high-impedance circuits or distort video-frequency signals. When a capacitance type probe is used with a wide-band low-gain scope, the technician must be constantly aware of the amount of attenuation and possible distortion in his instrument and must compensate mentally for these limitations.

Probe and preamp

The new model HF3 LO-C Oscilloscope developed by Linear Equipment Laboratories consists of a probe of novel design with an input capacitance of only 1.5 μf and a wide-band video amplifier to compensate for the 40-db signal attenuation in the probe.

The Oscilloscope has an over-all gain of unity from the probe tip to the 80-ohm output terminals. The low output impedance prevents signal distortion that normally occurs when the scope has a high input impedance shunted by high cable capacitance.

The HF3 has a built-in selector for attenuating the input signal by 10 and 100 to prevent possible overloading of the video amplifiers. The scope is usually operated at maximum gain, with the Oscilloscope attenuator set for the lowest output that gives adequate vertical deflection. Thus any possible circuit overloading will occur in the scope where it will be more readily recognized and can be corrected by reducing the scope's gain.

The basic circuit of the probe of the HF3 is shown in Fig. 2. The high input capacitance usually caused by the probe shield is reduced by using C_1 as the shield around the hot input lead. This results in the greatest portion of the stray capacitance, C_s , being shunted in parallel with cable capacitance.

The complete circuit of the HF3 is

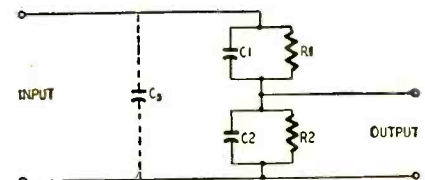

Fig. 1—Frequency-compensated probe.

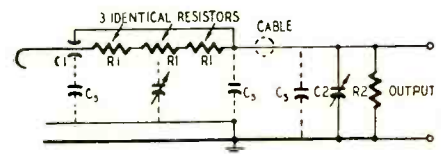

Fig. 2—Probe of the HF3 Oscilloscope.

shown in Fig. 3. The body of the probe houses R_1 —three 1.5-megohm resistors in series—shunted by a small gimmick capacitor. The portions of the compensating circuit equivalent to C_2-R_2 (in Figs. 1 and 2) are a part of the attenuator. The input stage is a 6U8 with its pentode section connected as a shunt-peaked video amplifier and its triode section as a direct-coupled cathode follower. The second stage is a 6AH6 with shunt peaking in its plate circuit. A 1-megohm variable resistor in the grid circuit is the low-frequency compensation adjustment. The output stage is a 12BY7 cathode follower with an 80-ohm output impedance. B plus

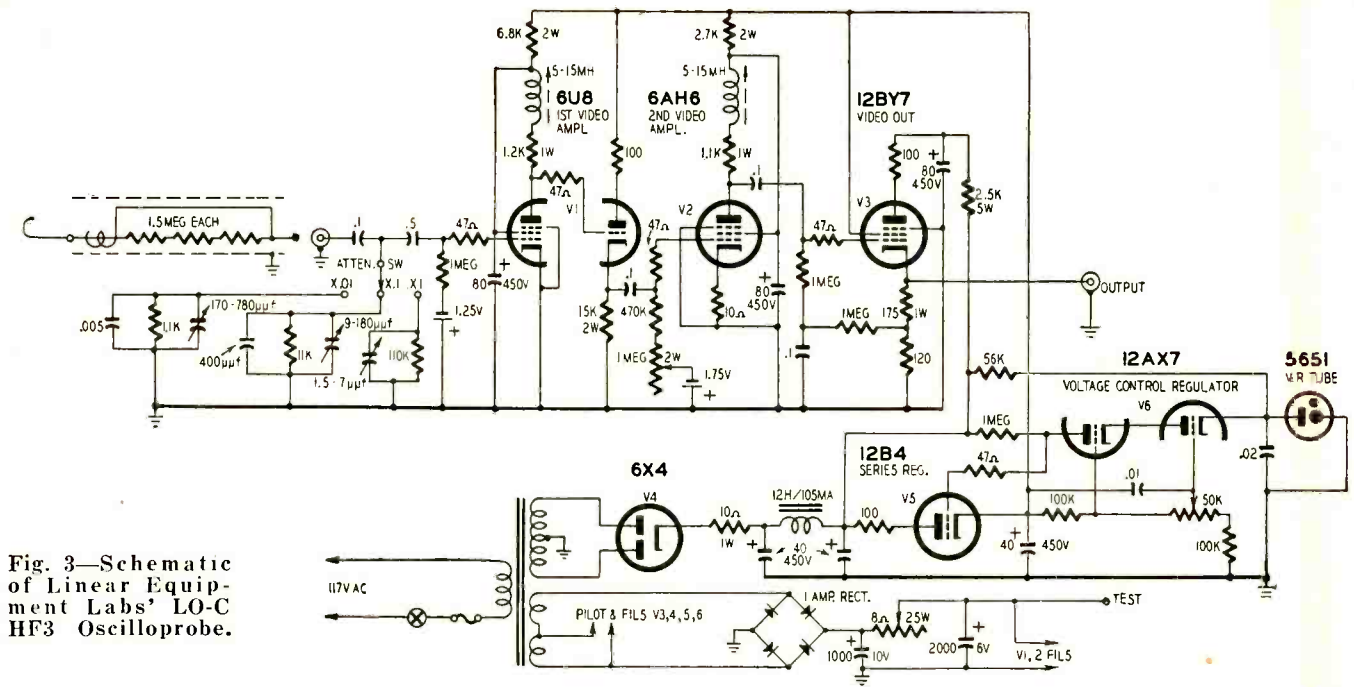

Fig. 3—Schematic of Linear Equipment Labs' LO-C HF3 Oscilloprobe.

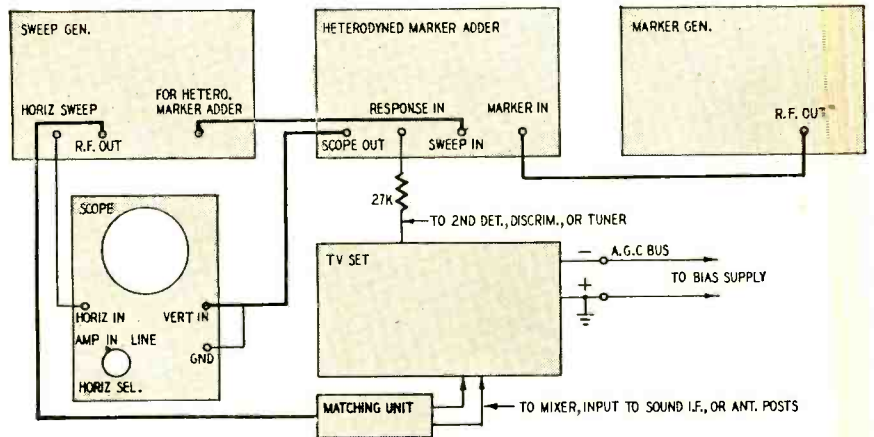
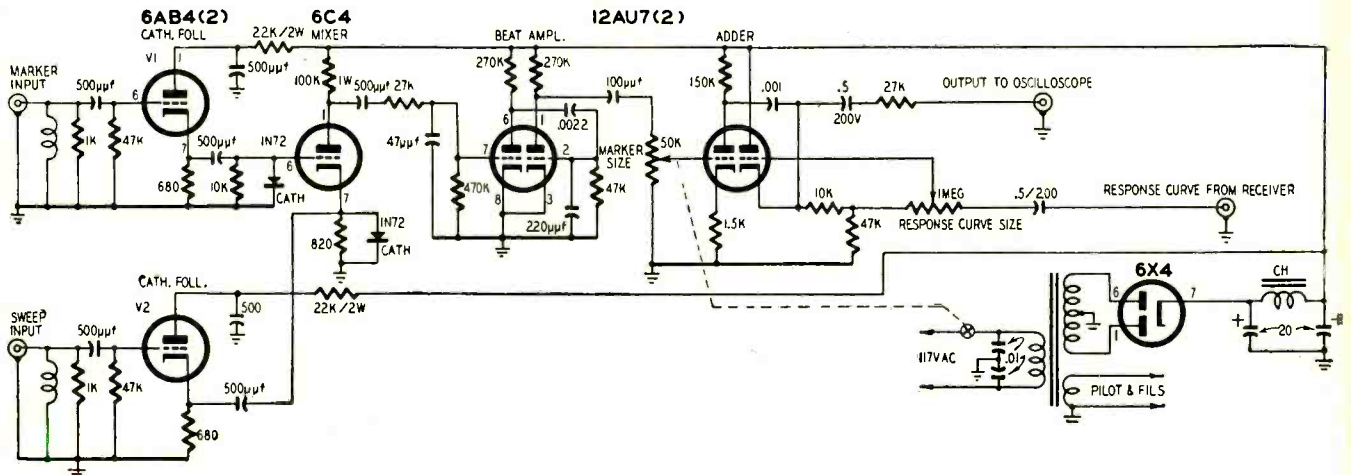

Fig. 4—Typical equipment set-up using a marker adder for circuit alignment.

Fig. 5—Schematic diagram of the Hickock model 691 Heterodyne Marker Adder.



TEST INSTRUMENTS



Fig. 6—Device provides sharp pulses.

voltages are regulated by a 3-tube voltage-regulator circuit using a 12B4 series regulator, 12AX7 control tube, and a 5651 voltage-regulator tube to supply the reference voltage. The heaters of the 6U8 and 6AH6 are supplied with d.c. voltages developed by a 1-amp bridge rectifier across the heater winding of the transformer.

The video amplifier section of the Oscilloprobe may be used alone as a scope or v.t.v.m. preamplifier with a gain of 40 db.

Specifications for the HF3 Oscilloprobe are: Over-all gain, X 1, X 0.1, and X 0.01; bandwidth, 5 cycles to 12 mc plus or minus 3 db; input impedance, 4.5 megohms; input capacitance, 1.5–2 μf ; maximum input voltage, 150 a.c., 600 d.c.; undistorted output, 4.5 volts maximum.

Sweep marker injection

When using a sweep generator to check alignment or response of TV r.f. and i.f. circuits, the service technician often finds that the marker pip disappears when it falls along the base line or close to a trap frequency where it is needed most. Instruments called *marker adders* or *marker injectors* have been developed to provide uniform marker size independent of the circuit under test. When this instrument is used, the marker signal is not fed into the TV circuits where it can load the response curve. Instead, it is fed into the adder along with a part of the sweep voltage. The two signals are heterodyned to produce a beat that is filtered, amplified, and then superimposed on the receiver's response curve before being fed to the scope. A typical setup for using a marker adder during TV and FM circuit alignment is shown

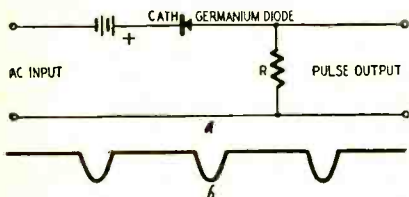

Fig. 7—Clipper circuit and waveform.

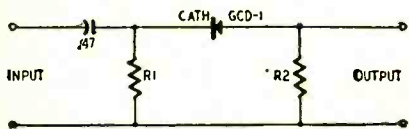

Fig. 8—Capacitor replaces battery.

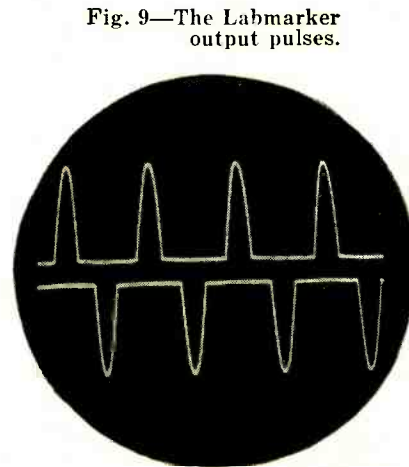

Fig. 9—The Labmarker output pulses.

in the equipment layout of Fig. 4.

Hickok has recently developed the model 691 Heterodyne Marker Adder shown schematically in Fig. 5. The signal from the marker generator is fed to cathode follower V1, and a part of the sweep voltage is fed to cathode follower V2. The outputs of these two

is connected to the output terminal. The MARKER SIZE and RESPONSE CURVE SIZE controls adjust the response-curve and marker amplitudes as they appear on the scope.

Timing-mark generator

The Berkshire Labmarker (Fig. 6) is a waveshaping device for converting a.f. or r.f. sine waves into sharp pulses for triggering and gating applications and for intensity-modulating a C-R tube for oscilloscope observations. The Labmarker can hardly be considered a necessity for radio, TV, or audio servicing, but it is useful in checking and calibrating oscilloscope sweep generators and audio- and low-frequency r.f. oscillators.

Fig. 7-a shows a conventional diode clipper with a bias battery in series with the a.c. input. The battery voltage is polarized so the diode passes only the portion of the negative half-cycle that exceeds the bias. The output (Fig. 7-b) is a series of negative pulses.

Fig. 8 shows how the battery is replaced by a capacitor to develop a practical battery-less self-contained instrument. This circuit has the advantage that initial conduction of the diode automatically charges the capacitor to the right value for good clipping. The output pulse width is determined by the ratio of R1 and R2.

Six different Labmarkers are available. Two produce negative pulses handy for scope-trace blanking, two models produce positive pulses suitable for trace intensification, and two models have two clipper circuits in parallel—one produces positive pulses and the other negative (Fig. 9). The char-

BERKSHIRE LABMARKERS

SPECIFICATIONS	Model					
	1-U	1-N	1-P	1-U1	1-N1	1-P1
Max. input volts	34	34	34	36	36	36
Pulse duration, cycle	0.3	0.3	0.3	0.1	0.1	0.1
Pulse amplitude—input volts	0.5	0.5	0.5	0.05	0.05	0.05
Max. output imp.	10K	10K	10K	4K	4K	4K
Input imp. during pulse	8K	9K	9K	4K	4K	4K
Input imp. between pulses	50K	100K	100K	500K	1 meg.	1 meg.

stages are fed to grid and cathode, respectively, of the 6C4 detector (mixer) where they heterodyne to produce sum and difference frequencies. A low-pass filter eliminates the sum frequency and passes the difference frequency on to the 12AU7 beat amplifier. The triodes of this stage are cascaded to develop a gain of about 200. The coupling components are selected to provide sharp markers.

The output of the beat amplifier is coupled to one triode of the 12AU7 adder tube. The output from the circuit under test is fed to the other triode through the RESPONSE CURVE FROM RECEIVER terminal. The adder superimposes the marker pip on the response curve. This appears on the scope that

acteristics of the various models are given in the table. The lower frequency limit is 25 cycles and the upper limit is 1 mc on all models. The units are 5.5 inches long over-all and 1.5–1.75 inches in diameter.

In the model 1-N, 1-P, and each section of the 1-U, R1 is 100,000 ohms and R2 is 10,000 ohms. In the 1-N1, 1-P1, and 1-U1, R1 is 2.2 megohms and R2 is 3,900 ohms. Diode polarity is reversed from that shown in Fig. 8 in the positive half of the 1-U and 1-U1 and in the 1-P and 1-P1. The letters U, N, and P in the model numbers indicate the output polarity. U is for the dual units producing positive and negative pulses, N for negative pulse output, and P for positive pulses. END

LINEARITY GENERATOR for TV

By M. J. M. DUNSCOMBE

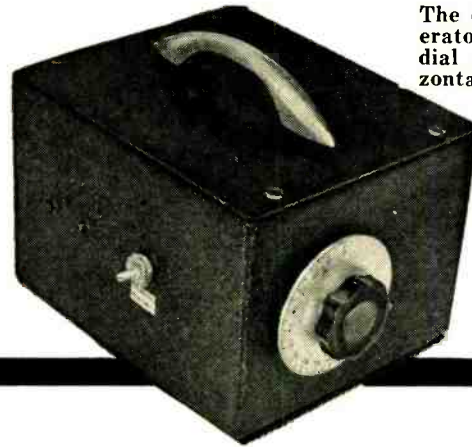

The cross-bar generator. Front-panel dial controls horizontal bars.

SEVERAL instruments that will produce a picture on a TV screen are available. The simplest type is the bar generator, which produces a variable number of horizontal or vertical bars. The applications of such a pattern are limited.

Using a cross-bar generator, black and white horizontal and vertical bars appear on the screen simultaneously. This type signal is far superior to the simple bar pattern, because its waveform is similar to the signal from a TV transmitter. Both line and field sync pulses are present, as well as a synthetic video signal. This reduces servicing time because it enables a technician to estimate at a glance the over-all performance of the receiver.

Unfortunately the cross-bar generators available are either too bulky for house calls or else their price puts them beyond the reach of many smaller service shops.

The solution to this problem is to

build a compact, portable version of the pattern generator. The construction time for this instrument is about four hours and the total parts cost is under \$15.

The output of the unit produces a cross-bar picture on a TV screen. (If desired a dot pattern can be produced by reducing the picture-tube brightness.) Picture size, horizontal and vertical linearity, sync stability and overall quality, as well as any fault in the set, are checked quickly by observing the image.

Fig. 1 is a block diagram of the cross-hatch generator. There are three separate oscillators. Vertical-bar oscillator V1-b develops vertical bars by oscillating at a multiple of the horizontal sweep frequency (15,750 cycles). Horizontal-bar oscillator V2 operates at a multiple of the vertical sweep frequency (60 cycles). The outputs of these oscillators amplitude-modulate V1-a, the channel oscillator that can be tuned from channels 2 to 6.

The schematic of the complete unit is shown in Fig. 2. A 6 x 5 x 4-inch utility box houses all the components, mounted on an aluminum chassis bolted to the sides of the cabinet. The physical layout is shown in the photographs. The positioning of the components is not critical and can be varied to suit the constructor's taste.

Circuit

The vertical-bar oscillator is a combined t.p.t.g. and inductive-feedback

circuit. Grid bias is developed by R2-C2. In designing this system I decided on producing 12 vertical bars on the screen. (For any particular receiver the actual number of bars visible may be one or two less, depending on the length of the flyback time. Thus, the oscillator frequency must be $15,750 \times 12$, or 189 kc. Coils L2 and L3 are the primary and secondary, respectively, of a 175-kc i.f. transformer. By adjusting trimmer capacitors C8 and C9, mounted on the transformer, the resonant frequency can be adjusted so that the output becomes a train of distorted sine waves at 189 kc.

A cathode-coupled multivibrator (V2) generates the horizontal bars. The number of bars is varied by rotating R10—the frequency of oscillation is controlled by time constant C4-R10. The frequency range is approximately 60 to 600 cycles. Thus, the number of horizontal bars appearing on the screen can be varied from 1 to 10. The output developed across R8 is a train of almost rectangular pulses. To stabilize the output of this circuit, V2 is locked to the power-line frequency through network R6-C3. This puts a small 60-cycle signal on the grid, making the output frequency an exact multiple of 60 cycles.

The pulses from V1-b and V2 amplitude-modulate the channel oscillator V1-a. The circuit of V1-a appears at first to be unconventional, though it is actually a Colpitts oscillator, as can be seen by adding the plate-cathode and grid-cathode capacitance of the tube to the diagram. The output frequency of V1-a is set by adjusting the slug in oscillator coil L1. Bias for the grid is produced by C1-R1. In the original model of the generator C1 was a 20- to 100- μf trimmer capacitor used to increase the frequency range of the circuit. This was later found unnecessary and a 47- μf mica fixed capacitor (Ceramicon) replaced the original trimmer. With this modification the oscillator now tunes through channels 2 to 6 as required.

Plate voltage for V1-a is obtained from the power supply through R4 and

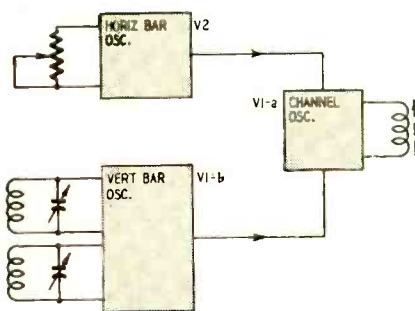

Fig. 1—Block diagram of generator.

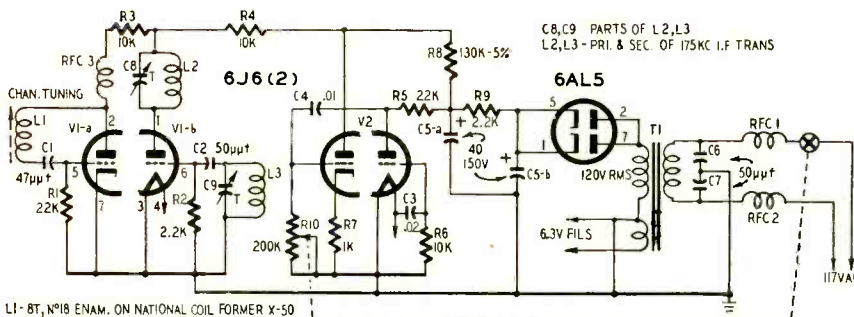
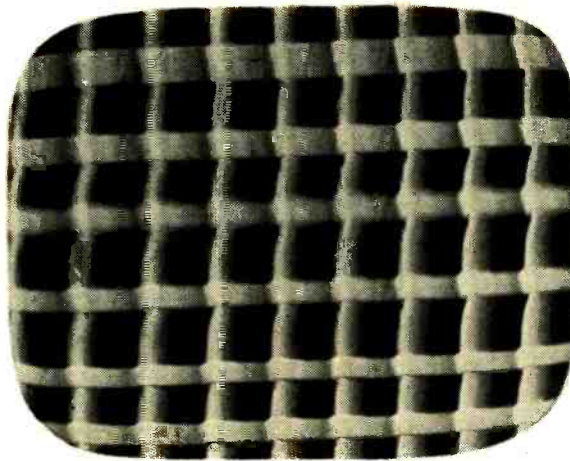

Fig. 2—Schematic of the cross-bar generator. Wiring is not critical.

TEST INSTRUMENTS



Vertical and horizontal bar pattern.

Top—This view of the cross-bar generator shows tube location. Below—Underchassis view shows physical layout of small components.

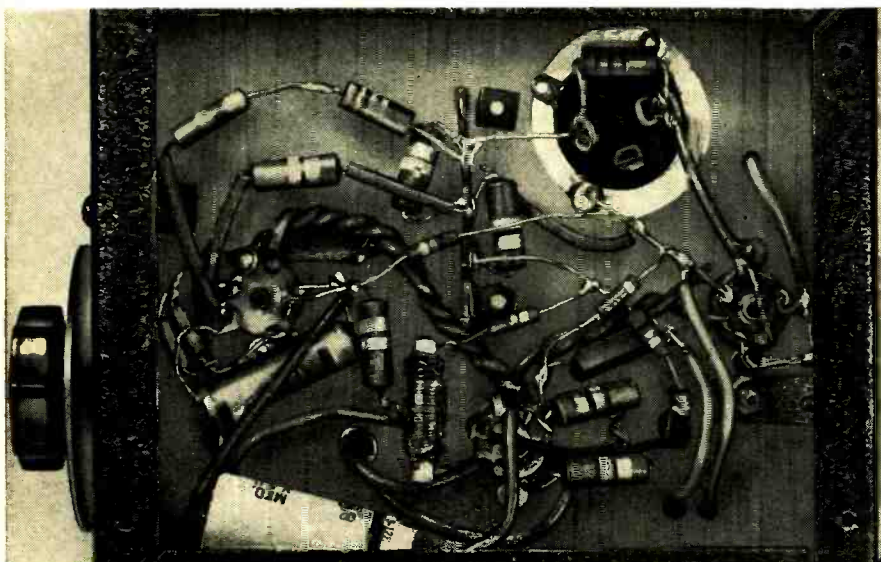
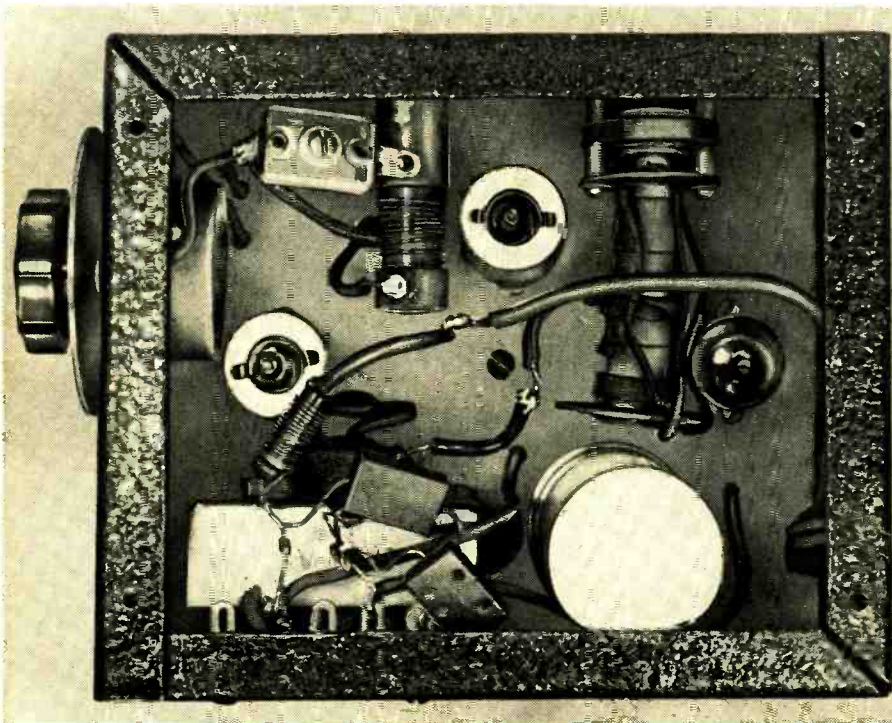

R8. Since these resistors are also the plate loads of V1-b and V2, the pulses from these tubes will be superimposed on the plate of V1-a, modulating the output. In this way a mixed output is produced containing pulses that are multiples of the vertical and horizontal sweep frequencies. When this signal is fed to a TV set, these multiple pulses trigger the vertical and horizontal sweep generators by automatically counting down to the field and line frequencies. At the same time these pulses pass through the video amplifier to the picture tube, modulating the beam and producing a cross-hatch pattern.

The power supply is a straightforward half-wave rectifier. Since the total current drain is only 6 ma, about 150 volts d.c. is available across C5-a for the oscillators. A 6AL5 was chosen as the rectifier, because of its low heater current.

No antenna connection to the TV set under test is needed as there is sufficient radiation from the generator to be picked up by any set within a radius of about 15 to 20 feet. Balanced filter circuit RFC1-RFC2-C6-C7 prevents r.f. from getting to the power line.

Construction is extremely simple. All leads to the channel oscillator should be kept short, otherwise it may not be possible, due to the increased capacitance of the circuit, to tune through the five low-band channels. The tuning slug of L1 can be seen projecting through the left-hand side of the cabinet. Behind this slug a hole was drilled to permit tuning C9. Horizontal bar control R10 is on the front panel. I later added an on-off switch to the back of this control.

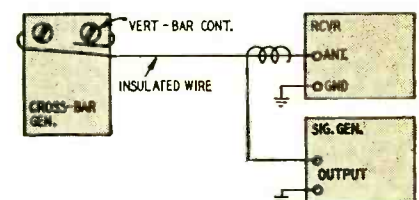

Fig. 3—Alignment setup for adjusting vertical-bar oscillator to 189 kc.

Phase-Shift Oscillator

By MILTON LAIKIN

When the complete unit has been built, the only adjustment necessary is to set the vertical-bar frequency of V1-b. As mentioned, this must be 189 kc. As most service shops have no receiver capable of tuning to this frequency, the layout of Fig. 3 can be used for the job.

Parts for crosshatch generator

Resistors: 1—1,000, 2—2,200, 3—10,000, 2—22,000, 1/2 watt; 1—130,000, 1/2 watt, 5%; 1—200,000-ohm potentiometer (Mallory Midgetrol U-43).

Capacitors: 1—47 μ f, ceramic; 3—50 μ f, mica (Aerovox Midget 1468); 1—.01 μ f, mica (Aerovox Midget 1467); 1—.02 μ f, paper; 1—40x40 μ f, 150 volts.

Miscellaneous: 1—s.p.s.t. switch (may be located on potentiometer); 1—coil (L1), 8 turns No. 18 enameled wire, wound on National X-50 or equivalent form; 1—primary and secondary windings of a 175-kc i.f. transformer (Meissner 16-6650 or equivalent for L2 and L3); 1—coil, 14 turns No. 18 enameled wire on Ohmite 470,000-ohm 1/2-watt resistor for RFC1 and RFC2; 1—coil, 50 turns No. 18 enameled wire on 1/4-inch form for RFC3; 1—power transformer, secondaries—120 volts at 15 ma or more, 6.3 volts at 1 ampere; 2—6J6, 1—6AL5, tubes; 1—chassis and cabinet; 1—line cord; 3—tube sockets; 1—calibrated tuning dial.

This is possible because the oscillations of V1-b contain harmonics that fall in the broadcast band. The fourth harmonic, i.e., 756 kc, is generally used.

Plug in the cross-bar generator and allow it to warm up for about 30 minutes. Take a lead from the antenna connection of a reliable broadcast receiver and wrap it around the cabinet of the generator. Connect the clip of the hot lead of the best AM signal generator in the shop onto the insulation of the wire going from the receiver antenna post. Switch off the modulation on the signal generator and tune it to 756 kc. Adjust trimmers C8 and C9 until a beat note from the two generators is heard in the receiver. To do this it will probably be necessary to adjust the output of the r.f. signal generator to a strong level. Tune the trimmers until the beat-note frequency drops to a minimum. The frequency should be set as accurately as possible.

Once calibration is completed, the cross-bar generator is ready for checking with a TV set. Turn on a set and tune it to channel 4. Rotate L1 until a pattern appears on the screen. At this point it may well be a wavering pattern of diagonal lines. Tune L1 for maximum contrast.

Rotate R10 to its maximum position. One horizontal bar should appear, drifting up or down the screen. To stabilize it adjust the set's vertical-hold control. Rotation of R10 should now increase the number of horizontal bars, which will drop in and out of lock as it is turned. Set R10 for 9 stable bars. A slight adjustment of the set's vertical-hold control may be required.

Steady the vertical bars by adjusting the horizontal-hold control of the receiver until the vertical bars lock in. The picture should now be a crosshatch of bars (see photo). As mentioned earlier the horizontal flyback time of the TV set in use will determine how many vertical bars are visible.

THIS phase-shift oscillator is extremely compact and stable, and is a handy test instrument for the experimenter and service technician. It is especially useful for signal tracing in audio-amplifier work.

Any oscillating device must include a system of feedback, in which energy is taken from the output circuit and fed to the input circuit in phase with the original signal. (If the phase is wrong, we have negative feedback and degeneration.)

Energy is often fed back by various combinations of transformers, inductors, and capacitors in the plate or grid circuits of vacuum tubes. These

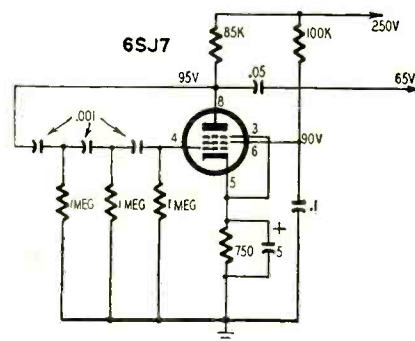

Typical phase-shift oscillator circuit.

components are often bulky and expensive, especially at audio frequencies. A better system is the phase-shift oscillator using a vacuum tube with only resistors and capacitors as circuit elements. The oscillator is so named because an R-C network produces the necessary phase shift between the input and output circuits. Any high-gain vacuum tube may be used—a low-gain tube will not supply sufficient feedback for the purpose.

The oscillator is shown in the diagram and its frequency is determined by the formula:

$$f = \frac{.09}{RC}$$

where R (each individual resistor) is in megohms, and C (each individual

If the picture does not fill the picture-tube mask, adjust the size controls until it does. At the same time the picture should be centered. Nonlinearity will show up as uneven spacing of the bars from top to bottom or left to right, and can be corrected with the linearity controls.

Vary the generator's channel tuning—check that the instrument radiates properly on all low-band channels. As the sound channels are tuned through, the generator signal will be heard. This provides a check of the audio side.



Phase-shift oscillator uses one tube.

capacitor) is in microfarads.

The only critical values are the phase-shifting resistors and capacitors. The circuit is fairly stable and the output waveform can be made nearly sinusoidal by adjusting the bias slightly. Any high-gain vacuum tube may be used in this oscillator.

The operating frequency may vary from the calculated value because of component tolerances. This can be corrected by using a variable resistor for the middle resistive element (the center resistor in the diagram).

Phase-shift oscillators are ideally suited for producing FM signals. One method is to place the middle resistor in the cathode circuit of a cathode follower. The cathode follower's output impedance shunts the middle phase-shift resistor. Varying the bias on the cathode follower varies its output impedance and shifts the oscillator frequency. A low-frequency signal on the cathode-follower grid sweeps the oscillator about its design frequency. (See "Beat-Frequency Tone Generator with R-C Tuning" in the May, 1948, issue of *Electronics*.) END

To use the instrument set it up near the receiver under repair and make the adjustments discussed. If a stable pattern cannot be obtained on the screen, the resulting picture or lack of it will indicate in which part of the set the trouble lies. By carrying out a standard trouble-shooting procedure the fault can be localized in a few minutes. No longer need sets pile up in the shop waiting for a station to put out a test pattern—repairs will be expedited and more satisfied customers will result. END

UTILITY AMPLIFIER and SIGNAL TRACER

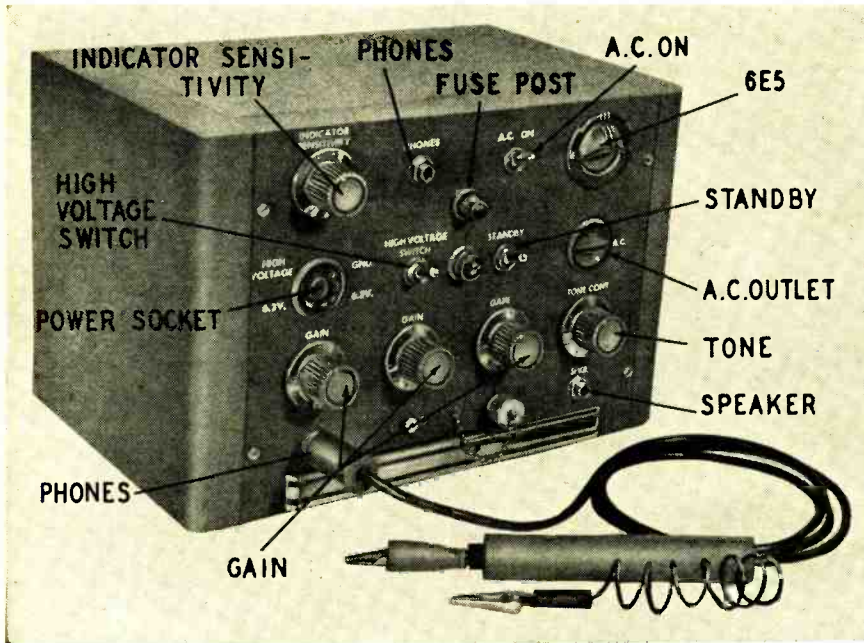

Front view of utility amplifier. Probe and various input sockets are shown.

By ALAN G. SORENSEN

A high-quality 5-watt audio amplifier that doubles as a signal tracer

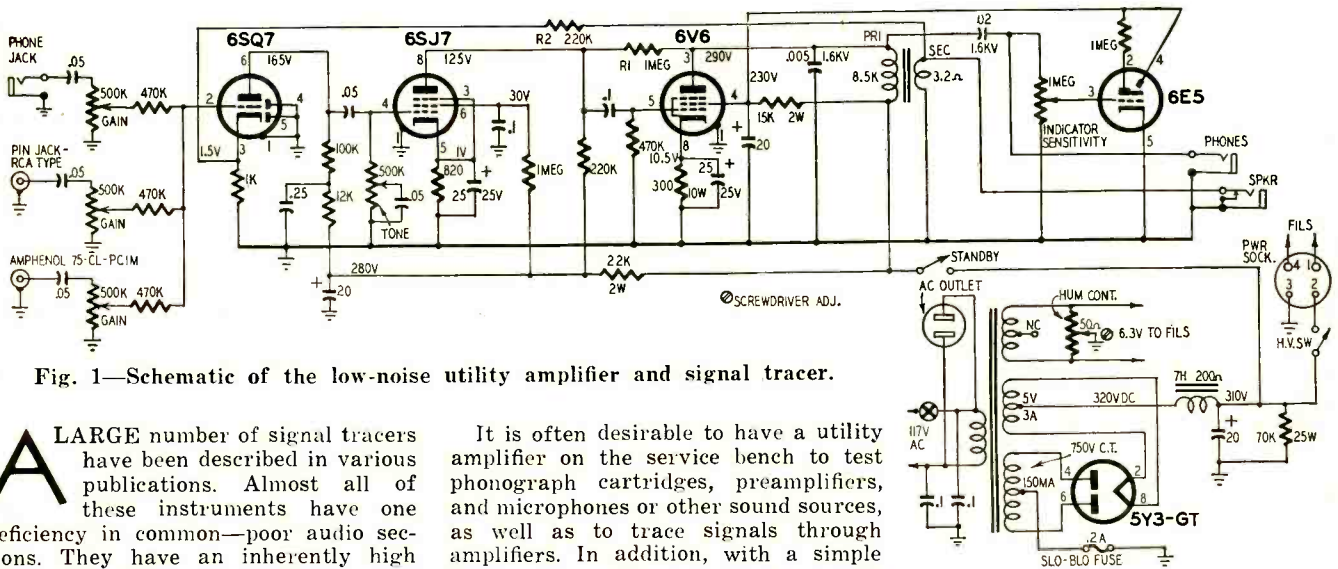

Fig. 1—Schematic of the low-noise utility amplifier and signal tracer.

ALARGE number of signal tracers have been described in various publications. Almost all of these instruments have one deficiency in common—poor audio sections. They have an inherently high noise and hum level which makes qualitative measurements next to impossible. What is most needed is a high-quality audio amplifier that is quiet, without hiss and hum.

The complete schematic of such an instrument is shown in Fig. 1. The tonal quality is very good and, with no input signal, the speaker is extremely quiet with only the slightest trace of noise. A person would have to place his ear directly in front of the speaker to detect any hiss, even with the tone control in treble position. The gain is adequate for almost any purpose. A 1-volt input signal will drive the amplifier to a full 5.5 watts output. A microphone whose level was -54 db provided an output of almost 1 watt.

It is often desirable to have a utility amplifier on the service bench to test phonograph cartridges, preamplifiers, and microphones or other sound sources, as well as to trace signals through amplifiers. In addition, with a simple probe, the unit can trace signals through radios.

Several useful features have been included in the instrument. Three inputs, each with a different type of connector and a separate volume control, provide a flexible arrangement. This virtually eliminates plug changing and makeshift hookups. In addition, several extension cables with a variety of connectors attached were made up to handle almost any service job.

Signal and line-voltage sockets are on the front panel. A cable with alligator clips is used for connecting into the circuit. High voltage (up to 310 volts d.c.) and filament voltage (6.3) is available. A switch in the B plus line permits the power to be turned off

when the instrument powered by the tracer is not in use. The unit draws about 50 ma, leaving 100 ma for external use. If the full 150 ma of the power supply is required, the STANDBY switch may be used to disconnect the B plus voltage from the instrument. A choke-input filter provides the best possible power-supply regulation. As a safety measure, the 0.2-ampere fuse is wired into the B supply. The fuse is of the Slo-Blo type to reduce needless fuse blowing and is replaceable from the front panel.

A 6E5 electron-ray tube is used for making rapid checks of comparative gain levels. This tube has its own gain

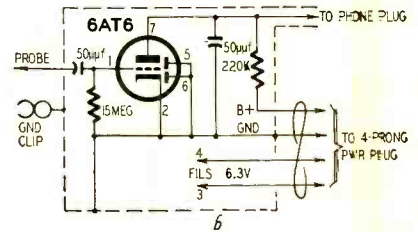
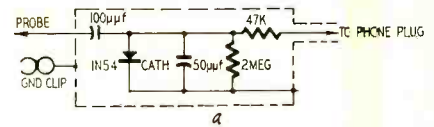
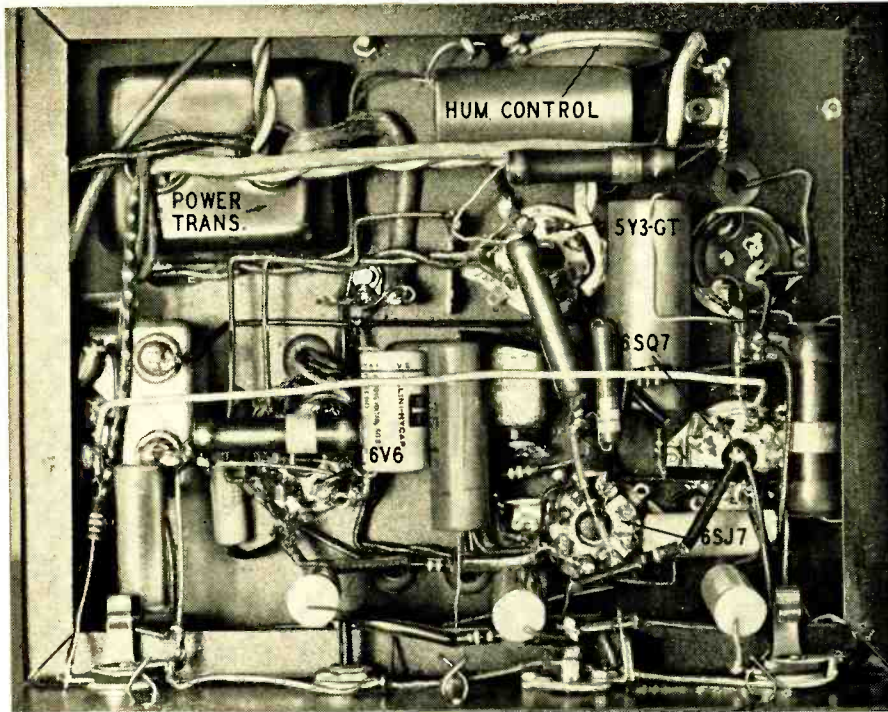

Fig. 2-a—Probe uses germanium crystal.

Fig. 2-b—Tube gives added amplification.

Underchassis view. Filament wiring is twisted and isolated from grid circuits.

control. One service job that can be done very quickly by this method is checking the balance of a push-pull amplifier. A steady tone is applied to the amplifier under test. The a.f. signal probe is placed on each plate and the electronic eye is used to observe signal strength. The INDICATOR SENSITIVITY control is adjusted so that the 6E5 shows only a small wedge. Slight differences in signal level are easily detected. Another use is as a null detector.

Headphones may be used if desired. The loudspeaker jack is connected so that when the plug is removed the output transformer secondary will be shorted. (This was installed after the photos were made.) Either headphones or an a.c. voltmeter may be plugged into the PHONES jack.

The amplifier circuit requires very little explanation. Two feedback resistors, R1 and R2, are used to reduce tube noise and hum to a minimum. The value of R2 may be decreased, at the expense of over-all gain, to reduce the noise still further; or it may be increased to obtain more over-all gain. A switch can be installed to change the value of R2 in steps from about 15,000 ohms up to an open circuit. This would serve as a coarse gain control to be used when the measurements being made call for either very high or very low amplifier gain. If the amplifier motorboats or oscillates when wiring R2, reverse the secondary leads on the output transformer.

Two probes are used with the instrument: one for audio frequencies and one for r.f. The a.f. probe is merely a length of shielded cable with an alligator clip and ground lead. There is a choice of two styles of r.f. probe. The simplest is nothing more than a demodulator circuit (Fig. 2-a) using a 1N54 germanium crystal diode. This

Top view of utility amplifier shows mounting of all major components.

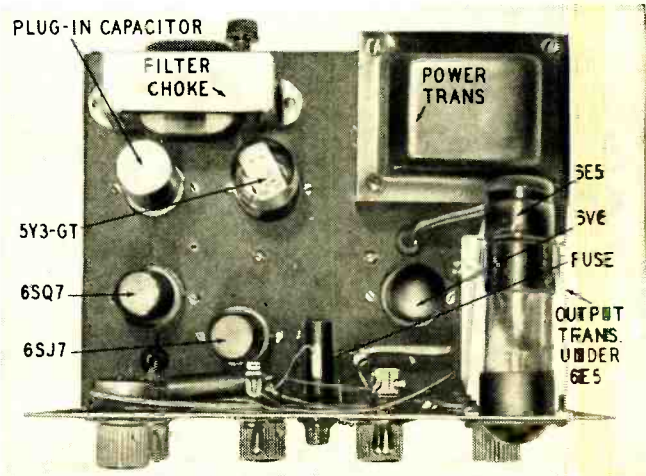

probe has the disadvantage of offering no signal amplification. Therefore it is not very useful if you want to pick up a signal back around the 12SA7 mixer in some little a.c.-d.c. set—especially if you live several miles from broadcasting stations. However, given enough signal strength, this type does a good job.

A more sensitive probe is a miniature triode connected as a zero-bias amplifier (Fig. 2-b). This will amplify the signal and is useful anywhere from the antenna on. It does have the disadvantage of requiring a power cable.

The choice of probes will depend upon the constructor's preference and his distance from broadcasting stations. If he lives farther than 25 miles from transmitters, the tube-type probe would be the better choice. Both probes should be shielded.

Wire the set with the idea in mind that the unit is a high-gain amplifier. Twist heater leads together and place

Parts list for amplifier

- Resistors:** 1—820, 1—1,000, 1—12,000, 1—100,000, 2—220,000, 4—470,000, 3—1 megohm, 1/2 watt, 1—15,000, 1—22,000 ohms, 2 watts; 1—300 ohms, 10 watts; 1—70,000 ohms, 25 watts. 1—50-ohm, wirewound, potentiometer; 4—500,000-ohm, 1—1 megohm, carbon, potentiometer.
- Capacitors:** 1—.005 µf, 1—.02 µf, 5—.05 µf, 4—0.1 µf, 1—0.25 µf, paper; 1—20.20 µf, 350 volts, 1—25.25 µf, 25 volts, 1—20 µf, 450 volts, electrolytic.
- Miscellaneous:** 1—6SQ7, 1—6SJ7, 1—6V6, 1—6E5, 1—5Y3-GT, tubes; 1—power transformer, 750 volts ct at 150 ma, 5 volts at 3 amps, 6.3 volts at 2 amps (Stancor PM-8411); 1—filter choke, 7 h at 150 ma, 200 ohms (Stancor C1710); 1—6E5 assembly; 5—tube sockets; 1—output transformer, 8,500-ohm primary, 3.2-ohm secondary (Stancor A3849); 1—0.2-amp fuse and holder; 2—open-circuit jacks; 1—shorting-type jack; 1—jack, RCA type; 1—jack, Amphenol 75-CL-PCIM; 3—s.p.s.t. switch; 1—a.c. female socket; 1—4-pin female socket; 1—chassis; 1—cabinet.

them well away from the grid circuits. A HUM CONTROL potentiometer is placed in the heater circuit. It should be adjusted for lowest hum level. The B plus line is well filtered, and there should be no motorboating or oscillation. All ground leads for the 6SQ7 and 6SJ7 should be connected to a common ground bus wire.

END

TOUGH U.H.F. INSTALLATIONS

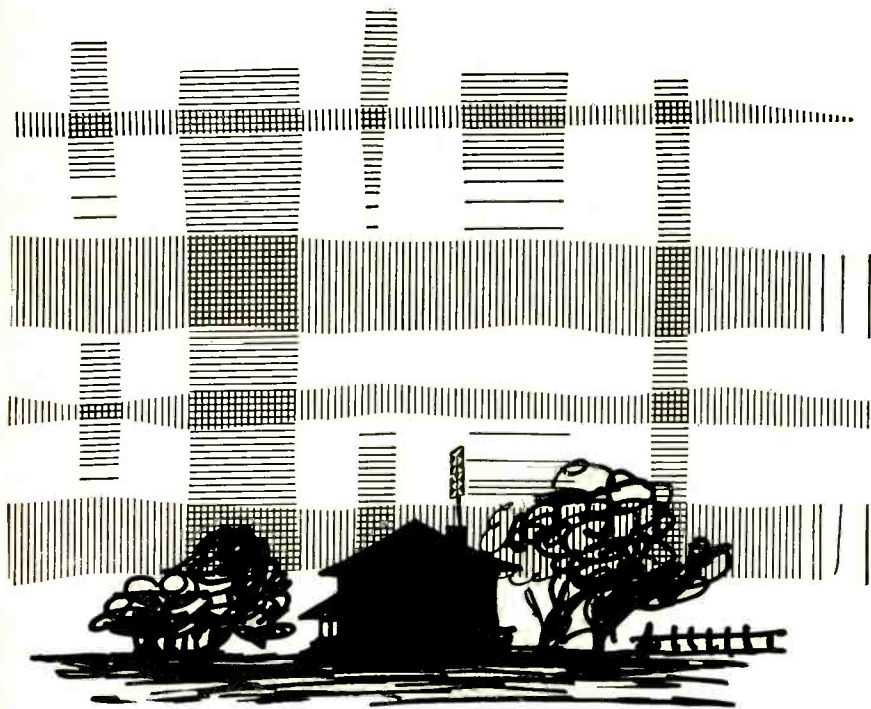

Fig. 1—Distribution of vertical and horizontal layers as seen by our artist.

THOSE of you who are not familiar with u.h.f. and its problems will have to learn the hard way or have someone handy who has had the experience. No matter how much you know about v.h.f., the new u.h.f. station in your town will give you many an anxious moment.

I don't intend to go into techniques for the average primary-area antenna installation. Of more interest to the dealer are the sales he is losing in the areas where good reception is difficult or impossible to obtain.

The customer in these shaded or fringe areas *must have* a TV set with high sensitivity. Often a good antenna crew is helpless because the TV set was not engineered for difficult signal conditions.

After the receiver has been selected, it is up to the antenna crew to bring in the picture. Real know-how is needed.

There is a very important condition known as *layer effect*. That is, the existence of layers of good signal area—one on top of the other—separated by dead spots. If that were all, then it would be necessary only to keep raising the antenna higher and higher until a good layer is found. That might be all right in v.h.f., but forget it in u.h.f.! There are *vertical* "layers" as well as horizontal layers. At say 10 feet above the roof in one spot there is nothing and 3 feet either side of that spot is a hot signal. So we begin to learn that height is not the answer to fringe areas with u.h.f. These so-called layers are shown in the drawing (Fig. 1).

If obtaining a good signal from one station is the problem, then we must

select an antenna that will do the job. The Yagi and colinear u.h.f. antennas will do a good job. The colinear, though more costly, can be used very well at u.h.f. because of the smaller wavelengths. At v.h.f. this antenna has a high wind resistance and is too large and heavy.

I do not recommend stacking Yagis. Two- or 3-db gain is not worth the added expense and trouble. You will also find that you can lose everything you gained with one Yagi when you stack them, because one may be in the hot layer while the others may be completely in a dead spot. U.h.f. layers in the real fringe and shaded areas are only about 5 to 6 inches thick. So you can see that stacking Yagis is no solution. (Part of the losses experienced when stacking antennas may be due to mismatch caused by improper design or selection of the stacking bars.—*Editor*) The colinear seems to work well because there are a lot more elements (driven) that are liable to catch two or more layers instead of one. The larger all-channel antennas such as the trombone have met with success partly because they can contact much more signal. In any case, several types of antennas should be taken along and tried.

It has been my experience that a field-strength meter is practically useless and a waste of time. The simpler and most accurate method is the "watch-and-talk" method. This consists of a pair of sound-powered phones with a separate lead. One man watches the TV set while the man on the roof does the testing. Do not hook the phones

Using the "Layer effect" technique for obtaining greater signal strength in weak-signal areas

By C. F. MAHLER, Jr.

into the u.h.f. transmission line as a short cut. There is no way, to my knowledge, of combining the two functions in one lead. Not in u.h.f. anyway.

In locations blocked out by hills or such within the strong primary signal area, *always* start your tests closest to the ground. In these areas a very strong ground wave might turn out to be the only signal. The ground wave will diminish farther out from the station, depending upon the power of the transmitted signal. It is not uncommon here in Portland, Ore., to see antennas in the front yard or low on the side of the house. One extreme instance I can remember was finding the *only* signal 7½ feet from the living-room floor.

You probably have heard by now that flat 300-ohm line is no good for u.h.f. The reason is that water on the line will disturb the magnetic field around

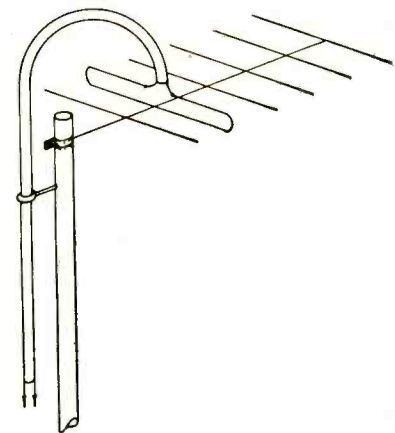

Fig. 2—Lead-in is looped over antenna.

the wire. You must use a round or tubular line. Open line has a tendency to pick up line ghosts and will short out when it snows. Some manufacturers recommend that you seal the top end of the tubular line to keep out the water. Since the line is hollow on the inside, this procedure should be avoided. *Do not seal the top end.* When you have heavy condensation inside the tubular line the droplets of water collect and are trapped in the line until it dries out. Always loop the lead-in over the top of the antenna and leave the ends open to let the air circulate (Fig. 2).

If you use a lightning arrester, make sure it doesn't short out the antenna or cause signal attenuation. Some arresters that worked O.K. on v.h.f. are no good for u.h.f.

When checking the roof of a home for an antenna installation, start at the lowest point possible on the roof and walk back and forth covering everything at that height before raising the antenna. This is the only way—there are no short cuts. You might hit something right at the start but you will never know there wasn't something better elsewhere on the roof. Remember, you are getting paid to bring in the best picture available. You must test to find vertical and horizontal layers.

The vertical layer goes straight up and provides a good signal. If you are trying to pull the signal through heavy tree growth, this layer will be strong down low and weaker up higher until you get over the tops of the trees. If it is raining and the trees are wet, it is extremely difficult to pull the signal through the green growth, but you probably will find it 3 to 10 feet from the ground. The trunk section of the tree group, of course, has more openings than the heavy green sections. Trees will often cause bad streaks and ghosts. You then must try the corner-reflector type antenna, or any with a good front-to-side ratio.

The horizontal layer runs parallel with the ground. Sometimes this layer will be very short. You can easily lose it if you are not careful to mark a place on the roof where you notice it. At other times this layer will be strong from one end of the building to the other. However, this is rare when in a very weak signal area. As a final reminder, don't think just because you are in the fringe that you have to test 20 or 30 feet in the air. Give the low spots a chance. You may be surprised.

I think this idea of layers of signal in patches around the building will enable you to do a better job on those tough ones. (Part of the horizontal and possibly the vertical layer effect may be due to the changes in the impedance of the antenna and its vertical angle of radiation, due to the variation in its height above ground as it is moved in search of a sensitive spot. This point is very important theoretically, though it will not have to be taken into consideration by the practical installation man.—*Editor*)

END

tv dx

October-December

WITH the summer of 1954 the best season for sporadic-E dx in many years, the observation and recording of TV dx is becoming a major hobby. The pile of reports already on your editor's desk is much higher than that for any previous entire year.

Who would believe, for instance, that 156 different television stations could be identified in a single location? Yet that's the record of 16-year-old Bedford Brown, Jr., Hot Springs, Ark. In June, 1954, alone, he identified 114 stations, 84 of them by sporadic-E dx. On a single day, June 7, Observer Brown logged 64 stations. Can anyone top this record?

Our old friend, Louis Matullo, Washington, Pa., now has logged 134 different stations, which is the Eastern record, as far as we know. Fred Von Genten, Berne, Ind., has 111, 91 of them photographed. Fred picked up 65 stations in June, 44 of them on the 24th. Roger Anderson, Madison, S. D., has 91, of which 29 were received on June 1.

Dx records have been made and broken, too. PRF-3, São Paulo, Brazil, has been reported several times. Best dx on this or any other TV station we know of is a logging by Bob Cooper, Lafayette, Calif., nearly 7,000 miles. HGLO (Colombia?) is reported by John Aldridge, Winston-Salem, N. C., as picked up at 8 p.m., July 4. Anyone know more on this one?

TV dx is the motivating factor of numerous clubs and societies around the country; some old, some new. There's the Newark News Radio Club, Newark, N. J., and the National Radio Club, Box 38, Kensington Station, Buffalo, N. Y., both old-line radio clubs, now featuring TV dx as well. Kenneth Bush, 60 Grace St., Buffalo, N. Y., sends us a feature story from a Buffalo paper about the "E Skippers," some 50 TV dx-ers of the Buffalo area. Bob Cooper, 1016 Sunnybrook Drive, Lafayette, Calif., operates the American Ionospheric Propagation Society, complete with bulletins and predictions of things to come. Yes, TV dx-ing is developing into quite a game!

Now let's have a look at the prospects for the balance of 1954. In the last quarter we pass through a marked change in both weather and radio propagation seasons. Through October we can still count on fine tropospheric bending in fair, calm weather, particularly in localities near large bodies of water. Tropospheric propagation will hold up well in the warmer climates through November. There will be little sporadic-E dx either month.

The middle of December will bring a renewal of E_s dx, for a couple of weeks either side of the Christmas holidays. This winter peak, though much shorter than the summer one, is good for plenty of surprises. END



AL KAUFMAN

COLOR TV CIRCUITS

By KEN KLEIDON* and PHIL STEINBERG*

*Part V—The I-Q system
of color demodulation
and its circuitry*

THE I-Q system has a distinct advantage in that it can produce greater color detail than is possible with the R-Y B-Y system. This advantage is similar to that of a monochrome receiver having an i.f. and video amplifier response to 3.8-mc over one with a response to only 3.2-mc. While many technical people may contend that the wider-band receiver is superior because it is capable of reproducing a picture with greater detail, tests have shown that most nontechnical viewers observing both pictures notice little if any difference in picture quality. One or possibly two tubes may be saved, with proper design, in the 3.2-mc receiver (three instead of four i.f.'s and one instead of two video amplifiers). A greater number of stages usually will be required for the 3.8-mc receiver because of the problem of obtaining the required bandwidth and adequate gain.

This comparison applies to color demodulators in that the I-Q system affords greater color detail because of the higher-frequency color response (1.3 mc). In the R-Y B-Y system, color detail is presented up to only 600 kc. The finer detail in the picture, for both systems, is provided by the luminance (Y) signal which has a frequency response up to approximately 3.5 mc. The detail-reproducing ability of the luminance signal is not affected by the type of color demodulator employed. Only color detail is affected.

The demodulators used for the I-Q system are similar to the R-Y B-Y demodulators covered in our last article. The I and Q signals are demodulated at a 90° phase difference identical to the R-Y signals as shown in Fig. 1. The Q demodulator can be considered identical in action to the B-Y demodulator; the 600-kc filter in the plate circuit is also identical. The I demodulator may be considered similar to the R-Y demodulator. However, there is a major difference in the plate-circuit low-pass filter, which has a response to 1.3 mc as shown in Fig. 1. A more elaborate type of low-pass filter is required compared to the simple 600-kc filter which was discussed in the last article. The elaborate filter is necessary because a time delay is required for the I channel due to the higher frequency response. This time delay is usually included in the design of the low-pass filter, Fig. 2, and is necessary for the same reason a delay is put in the luminance channel.

Another dissimilarity between the I-Q and R-Y B-Y demodulators is the difference in phase between the two oscillator signals and the color burst signal. This difference in phase is 33° between the Q and burst signals (as explained in Part IV of this series) and requires shifting the oscillator phase by 33° with respect to the burst signal, before application to the demodulator suppressor grids.

Two methods that are commonly employed in present color receivers are illustrated in Fig. 3. One method involves slightly detuning the 3.58-mc burst takeoff transformer in the plate circuit of the first video amplifier, which effectively causes a phase shift in the 3.58-mc burst signal with respect to the 3.58-mc color subcarrier signal going to the bandpass amplifier. The other method is a special R-C phase-shift network between the oscillator and demodulators.

The demodulated color signals from the I and Q demodulators are coupled to phase inverters to obtain both negative and positive I and Q signals for application to the matrix circuit. The matrix circuit will differ slightly from the R-Y B-Y circuit in that a portion of both the I and Q signals are required for each primary color signal (red, blue, green). In the R-Y B-Y system the R-Y and the Y signals are mixed to obtain the red signal independent of the B-Y signal, and the B-Y and Y signals are mixed to obtain the blue signal independent of the R-Y signal. This fact is an important consideration when servicing. If, for example, an absence of blue is detected in a color picture of a receiver employing R-Y B-Y demodulators, one source of the trouble may be a defective B-Y demodulator whereas in the I-Q system one or both demodulators may be defective.

Reviewing the over-all operation of the I-Q demodulators, the color signal from the bandpass amplifier (see Fig. 4) is coupled to both the I and Q demodulators along with two signals 90° out-of-phase from the color oscillator. The resulting difference frequency (I and Q demodulated signals) is bandpass filtered and coupled to phase inverters for application to the matrix circuit. The negative and positive I and Q signals are mixed along with the Y or luminance signal, and three primary color signals are obtained, identical to the three color signals from the camera tube at the station.

The three primary color signals (red, blue, and green) from the matrix circuit are coupled to individual video amplifiers. There are two basic types of color video amplifiers. They are identical for all tri-gun color picture tube receivers using either the R-Y, B-Y, or I-Q demodulator system. The first type merely amplifies the red, green, and blue color signals before they are applied to the color picture tube. Fig. 5 represents a typical color video amplifier and d.c. restorer schematic diagram. As can be seen, a color video amplifier is almost identical to a monochrome video amplifier, except that, instead of only one, there are three.

The three color signals from the matrix circuits are applied to separate amplifiers which may use the same tube type and circuitry as many black-and-white receivers. The signal is amplified and coupled to the correct grid or cathode of the color picture tube. The color signals may be coupled to either the control grids or cathodes, depending on the polarity of the color signals. The three cathodes are connected together if the signals are coupled to the control grids, and the control grids

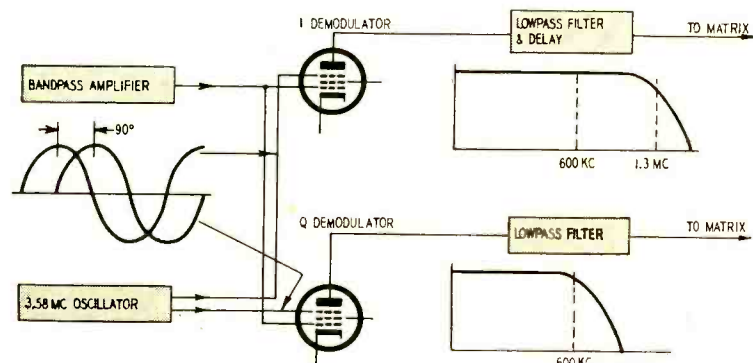

Fig. 1—The I and Q demodulators, with their 90°-separated screen supplies.

*Rathcon Manufacturing Company, Television and Radio Division, Chicago, Ill.

are connected together if the signal is coupled to the cathodes. The d.c. restorers' function (identical to that in a monochrome receiver) is to insure the proper color background at all times. Three d.c. restorers are used—one for each color—and are usually contained in one tube envelope.

All three color amplifiers are identical and each must have a frequency response to approximately 3.5 mc. This is necessary because during monochrome reception the three amplifiers are operating and amplifying their respective portions of the video signal. Therefore, servicing will be similar to monochrome video amplifiers and the same precautions must be observed with respect to rearranging leads and part replacements.

The cathode gain control, illustrated in Fig. 5, will be found in the green and blue color video amplifiers and is adjusted to provide proper color balance. The brightness control in the plate circuit of the d.c. restorer varies the d.c. potential and the operating level of the d.c. restorer. A green and blue brightness control will be provided. However, there is no individual red brightness control or red gain control. The red phosphor of the 15½-inch tricolor picture tube is very inefficient compared to the green and blue phosphors. For this reason the red signal is controlled only by the chroma and master brightness controls, and the green and blue gain and brightness controls are adjusted for proper over-all color balance. A more complete description and adjustment procedure will be covered in the next article.

Fig. 6 illustrates the second type of color video amplifier which may be used in a color receiver. Instead of deriving the three primary color signals from the matrix circuit, the color video amplifiers receive the color difference signals of $R - Y$, $B - Y$, and $G - Y$ from the matrix. The luminance or Y signal is coupled to the cathodes of the color picture tube, which are connected in parallel instead of being applied to the matrix.

Due to polarity inversion in a vacuum tube the $+R - Y$, $+B - Y$, and $+G - Y$ signals at the output of the color video amplifiers are applied to the individual control grids of the color picture tube. The Y signal applied to the common cathodes is identical to applying a $+Y$ signal to the control grids. Therefore, the color picture tube acts as a matrix. With this system a bandwidth of only about 1 mc is required for the color difference video amplifiers as only color video signals are being amplified and the 3.5-mc bandwidth monochrome or Y signal is applied directly to the color picture tube cathodes. D.c. restorers are required as with the other system but must be connected between control grid and cathode so as to respond to changes in the sync amplitude between grid and cathode.

TO BE CONTINUED

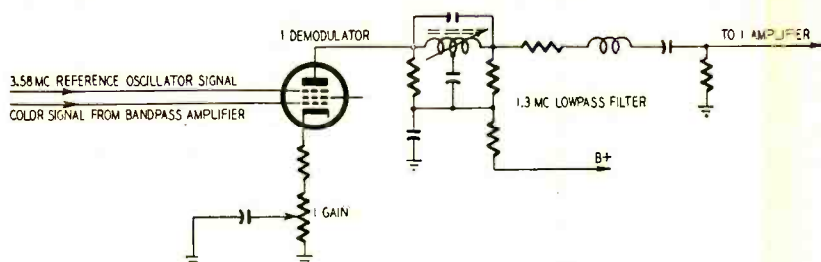

Fig. 2—The 1.3-mc low-pass filter in the plate circuit of the I demodulator.

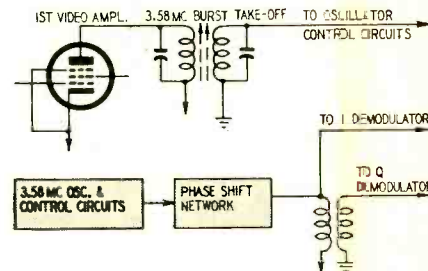

Fig. 3—Two methods of shifting phase.

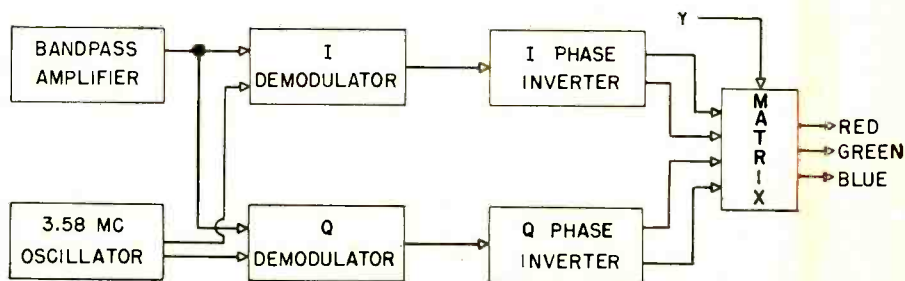

Fig. 4—Passage of the color signals through the I-Q and matrix networks.

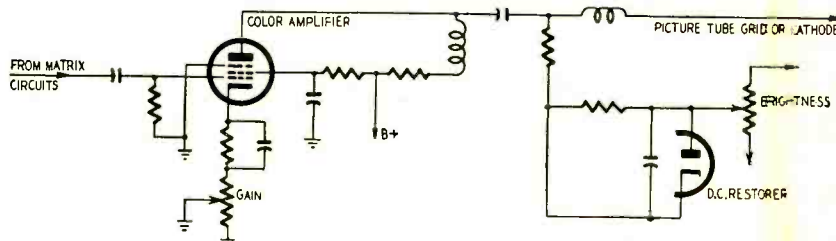

Fig. 5—The cathode gain control, brightness control, and d.c. restorer circuits.

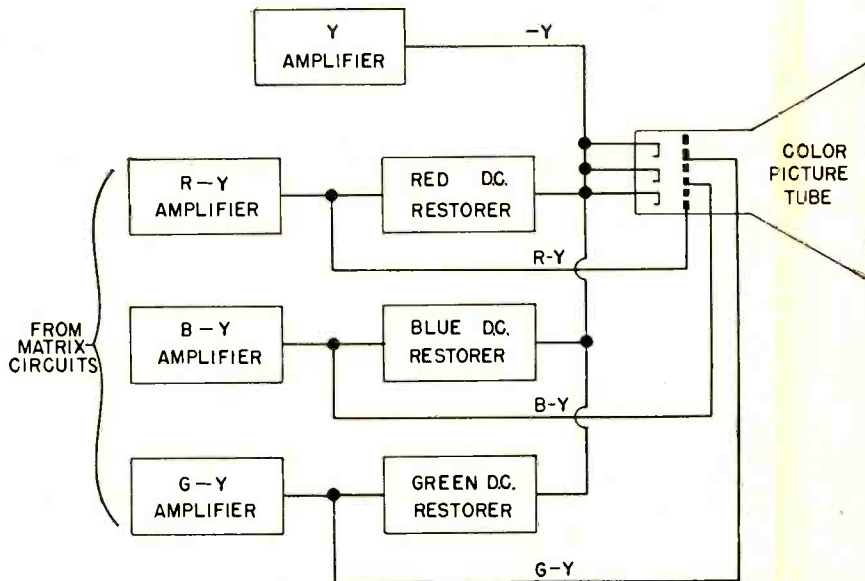
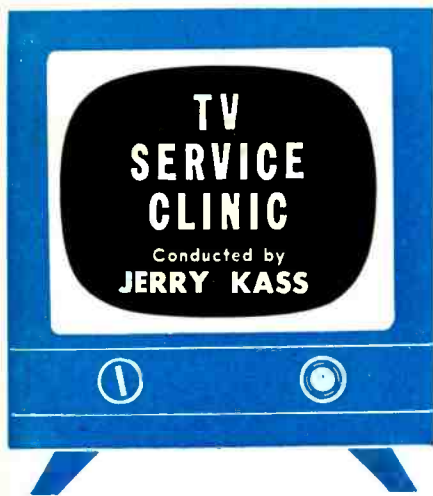

Fig. 6—A circuit which uses color amplifiers following the matrix networks.



A NONLINEAR horizontal sweep is not particularly difficult to diagnose. The picture is usually compressed over some part of the sweep and stretched over another. In severe cases horizontal fold-over can be seen.

Locating the defective component is an altogether different task. The linearity of the horizontal sweep depends on the proper operation of the horizontal discharge circuit, horizontal output circuit, linearity circuit, damper tube, and horizontal deflection yoke. Each one contributes to sweep linearity, and a defect in any one of them may make the sweep nonlinear.

Of all these stages, the importance of the linearity circuit is least appreciated. Living in the shadow of the output stage on one side and the damper on the other, it nevertheless is responsible for the smooth knitting together of the left and right sides of the picture.

Let us first look at the formation of the deflection-yoke waveform. The logical starting point is the output tube, usually operated as a class-B or class-C amplifier. The output-tube grid is fed by a combination sawtooth and rectangular voltage, and operating bias voltage is established by a grid leak.

The output tube comes out of cutoff (Fig. 1) and starts conducting at A, about one-third up its positive-going sawtooth. It continues to conduct for the remainder of the rising waveform. During this time of output-tube plate-current flow, the output transformer transfers the energy to the deflection yoke, and current flows there too. *This flow sweeps the trace from about the center, its undeflected resting place, to the right side of the screen.*

At the end of the peak positive grid drive, the input voltage suddenly reverses its polarity, and a large negative-going voltage drives the output tube far into cutoff. Since current flow through the primary of the output transformer stops, the magnetic field around the deflection yoke suddenly

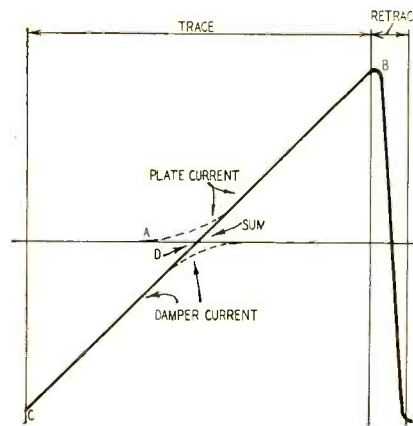

Fig. 1—Current flow through yoke.

collapses, shock-exciting the entire horizontal output system, and the horizontal retrace B—from right to left—begins. With the yoke current damped, this collapse would merely return the beam to the center of the screen. But the sudden reversal of the yoke's magnetic field drives the damper into cutoff and sends the shock-excited output system into oscillation (70 to 75 kc). The beam—instead of stopping at the center of the screen—keeps moving to the left edge (this is the necessary 7-microsecond retrace). If the shock-excited oscillation were to continue, the beam would swing wildly back and forth across the screen, causing many fold-over lines and extreme nonlinearity. Obviously, at this point the damper circuit must come into play.

Damping action

If no damping tube were connected across the deflection coil, the circuit would continue to oscillate until all the energy was used up. However, with the damper functioning, as soon as the retrace is completed and the spot starts a rapid swing from left to right, the damper begins to conduct (C), placing a heavy load across the deflection coil, damping the oscillations and making the first half of the left-to-right sweep linear.

As the rate of energy decay becomes nonlinear, the output tube, which has been cut off not only during the retrace period but also during the early part of the left-to-right sweep, begins to conduct and takes over the job of maintaining a linear sweep the rest of the way. Between the point of damper-current nonlinearity and the nonlinear start of output-tube current, there is a critical crossover point. At this point, the linearity coil, in series with the primary circuit of the output tube and the damper tube, takes over.

At the center of the screen, where both the output tube and the damper are conducting simultaneously, the linearity circuit plays its part.

Linearity circuit

This circuit is a simple low-pass filter resonant at 15,750 cycles—its inductance is variable. Its function is to

deform the nonlinear portion of the output-tube current so that it is equal and opposite to the nonlinear portion of the damper-tube current. This done, there is a linear transition from one curve to another (D), and thus a linear sweep.

To obtain a linear sweep, the start of conduction in the output tube and decay in the damper tube must occur simultaneously. To control the start of the output tube, we can vary its grid bias or vary the amount of signal fed to the grid (grid drive).

To vary the conduction period of the damper tube, the linearity coil must be adjusted. This controls the phase relationship between the current in the resonant linearity circuit and the damper-tube current. The relationship between these two currents affects the voltage across the linearity boost capacitor (damper "bias" voltage) and thus the conduction period of the damper. Thus, *the linearity circuit controls the sweep linearity around the center of the picture*—it shapes the output-tube plate current at the start of its conduction, and shapes the damper current at its period of decay. The result is a linear sawtooth current through the deflection yoke.

Servicing linearity circuits

In adjusting the linearity coil, remember that in some receivers good linearity can be obtained at two different coil settings. If the slug is turned to almost its innermost position, the picture will bloom. If this occurs, turn the slug for good linearity at the outer edge of its tuning range.

The service technician can get a good view of the sweep current in the deflection yoke by inserting a low-value resistor—10 to 20 ohms—in the low side of the deflection coil and observing the voltage across it with an oscilloscope. This will frequently provide an excellent clue as to the exact point of nonlinearity.

In checking the resistance of linearity coils, no general rule can be laid down. Even in the popular ranges of inductance, the coil resistance varies depending upon the type of winding used.

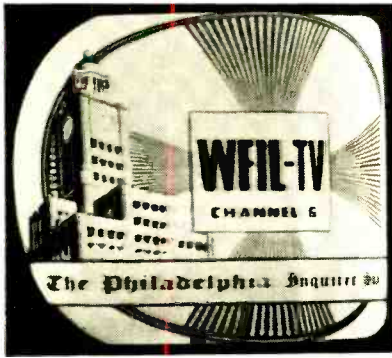

Courtesy RCA

Fig. 2—Extreme horizontal non-linearity

Poor linearity can take the form of an uneven sweep, or foldover. The linearity coil itself is effective usually only in the case of slight nonlinearity. In such a case, the coil should be varied. If turns are shorted, lowering the inductance, all adjustments will either be ineffective or critical and unstable.

A very common cause of nonlinearity is a defective boost capacitor or damper tube. These usually cause serious foldover of the picture at the left and white vertical bars, also on the left side of the screen. In severe cases, less pronounced bars can be seen across the entire face of the screen.

Many linearity problems arise as a result of overdriving the horizontal output tube. Check it! Adjust the drive control to eliminate the white vertical drive bar from the picture. Overdriving will shorten the life of the horizontal output tube.

In general, when the picture is stretched over the right side of the screen, invariably the trouble will be before the linearity coil. Check all voltages and components in the horizontal output circuit. An open screen bypass capacitor is a frequent troublemaker, as are the cathode resistor and capacitor. Also, check all components in the horizontal discharge and drive circuits.

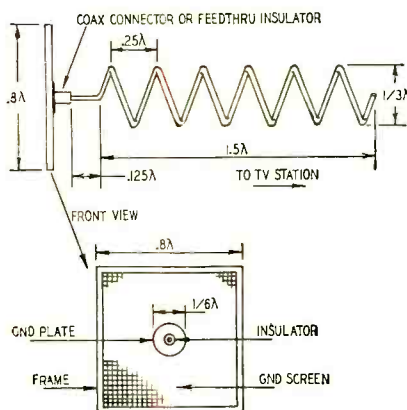
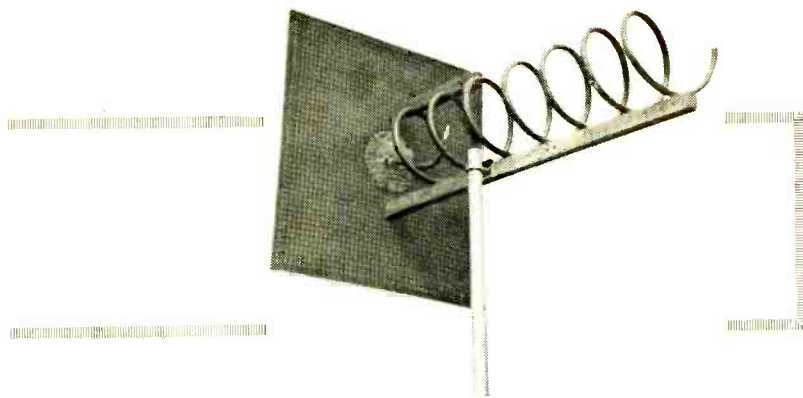

Fig. 3—Dimensions of helical antenna.

However, when picture stretch is on the left side, the trouble will usually be at or after the linearity coil. Check



The helical, a high-gain antenna.

for a defective linearity coil, damper tube, deflection yoke, and components in these circuits. See Fig. 2.

Using these same principles, foldover on the left side should be checked for in the damper and yoke circuits; foldover on the right side should be checked for in the horizontal output circuit.

Helical antenna

I have been trying for some time to get information on a helical antenna. I have written to several antenna companies, but none of them stock it. Could you please give me dimensions on the helical antenna as I wish to build one to receive a local u.h.f. station. I have heard these antennas have a very high gain.—E. V. D., Troy, N. Y.

The helical antenna is a fairly high-gain and broad-bandwidth unit. The principal reason for its comparative lack of popularity is the awkwardness of its construction. In practice, the antenna has been found very difficult to mount and presents a high wind resistance.

Fig. 3 shows the general configuration and dimensions of the helical antenna. The ground screen can be made from 0.5-inch mesh wire fastened to a wooden or metal frame. A small metal ground plate about $1/6$ wavelength in diameter should be soldered to the center of the ground screen. The ground plate may be made of sheet copper or tin. The transmission line (RG-63/U, RG-79/U, or RG-89/U) is connected to the antenna through a hole in the center of the ground plate. The center coaxial conductor goes to the helix and the outer to the ground plate.

The main construction difficulty comes in the winding of the helix. A soft grade of aluminum tubing or aluminum clothesline or ground wire should be used. It will have to be wound on a heavy wooden or metal cylinder. Precise calculations are pointless as the helix will "relax" when it is taken off its winding form. Use nonmetallic longerons to support the turns and to fix them in place.

The antenna has an impedance of approximately 125 ohms. Good results can be obtained using a length of 6

wavelengths. Since the antenna has a fairly broad bandwidth, the dimensions given are not critical. Obviously, the helical is practical only at u.h.f.

Internal corona

In an RCA model 9T57 there are one and sometimes two vertical bars down the left-hand edge of the picture. They look exactly like the Barkhausen lines that I have cleared up on many other sets, but the trouble has not responded to any treatment. I have replaced the horizontal output tube, damper tube, and high-voltage tube, and made adjustments of the horizontal drive control and the linearity control. I have even tried redressing leads and using an ion-trap magnet on the horizontal output tube.—R. W., N. Y., N. Y.

The vertical bar or bars at the left side of the picture, that look like Barkhausen oscillations, are probably the result of internal arcing in the $4.7\text{-}\mu\text{f}$ capacitor located in the plate circuit of the horizontal output tube. Such interference looks very much like the familiar Barkhausen oscillations but none of the usual remedies will correct it, and you seem to have used most of them. Before checking the output transformer, replace this capacitor.

Loss of a.g.c.

After a long period of perfect operation, the picture on a Philco model 48-1000 began to get very dark, but by adjusting the contrast and brightness controls I was able to get a passable picture. Then it became very difficult to synchronize the picture which became still darker. Any help would be appreciated.—M. L., Boston, Mass.

The symptoms you describe, that of a dark picture and difficulty in synchronizing, indicate trouble in the a.g.c. circuit. The chances are very good that the capacitor between the diode and triode plates of the a.g.c. amplifier tube is causing the trouble. Failure of this capacitor, either by shorting or leakage, places a positive voltage on the a.g.c. bus. This positive voltage is then fed to the grids of the r.f. and i.f. amplifiers.

Since capacitor leakage is sometimes difficult to check, this capacitor should be replaced.

END

TELEVISION...

it's a cinch

By E. AISBERG

From the original "La Télévision . . . Mais c'est très simple!" Translated from the French by Fred Shunaman. All North American rights reserved. No extract may be printed without the permission of RADIO-ELECTRONICS and the author.

Thirteenth conversation, first half: Positive and negative detection; polarity with one or two v.f. stages; detector component values; push-pull detection, will it work?

WILL—You know, every once in a while our talks remind me of a trip up a steep mountain trail.

KEN—I hope the road isn't getting too rough and rugged for you. We can take things a little easier—go into a little more detail, if you like.

WILL—No, that's not it! You know those hairpin roads that hang onto the side of a mountain, and give you the feeling that you're passing the same place over and over again, though you're really quite a little higher up each time? Well, every once in a while I have the feeling that I'm going back through my course in radio, because the things we've just been learning are—if you don't mind me stealing a radio-TV term—"parallel" to things I've learned in radio. For example, haven't we just been talking about r.f., frequency changing, and i.f.?

KEN—You've got a good comparison there. And you'll find as you go further and further up, the scenery is going to broaden out—get vaster and vaster. As you go through the various stages of a TV set, you're going to find the terrain a lot more rugged than in radio, because both the carrier and the modulating signal it carries are at much higher frequencies.

WILL—Well, I suppose we're just coming to the part of the trail where the signs they put up for tourists read: *Detection and Audio Amplification?*

KEN—You're right! We'll begin with the problem of detection today. Now that we've amplified our signal at higher and lower radio frequencies (in the r.f. and i.f. stages) the time comes when we have to get at the modulation it's carrying. After all, the r.f. is just a means of transportation for the signal. It gives us so many problems we sometimes forget that. It's very rapid transport—but nothing more. Your carrier is like a truck. We load the video signal on it at the transmitter. Now we've got to unload it—get the video frequency out of this r.f. carrier.

WILL—And when we detect our signal, we have to amplify it at audio frequency, I suppose?

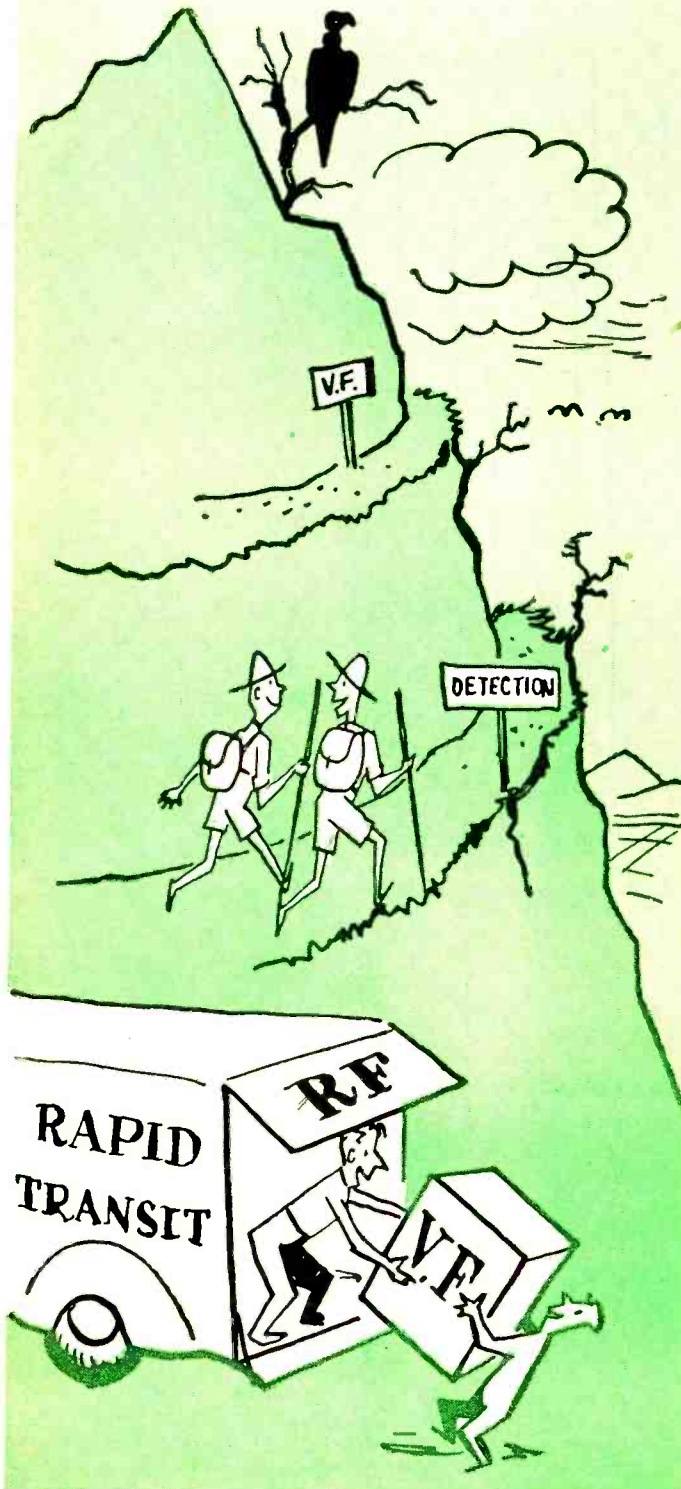

KEN—You can hardly use the term “audio frequency” for the video signal. It covers a band that runs practically from zero to several million cycles per second. Let’s give it its right name—video amplification!

A question of polarity

WILL—Beg pardon! I was just thinking of radio again. But let’s not get ahead of ourselves. Suppose we cover detection before going on to amplification. I suppose we can use a crystal, diode, or triode to detect a TV signal, just the same as a radio signal, and either grid-leak or grid-bias detection—if we detect with a triode?

KEN—Yes. I guess you *could*. But in actual practice you’ll find the diode most of the time, and grid-bias (or plate-bend) detection with a triode pretty rare. But the crystal is becoming very common. A crystal diode is less trouble than a tube and, because of its small capacitance, is better adapted to high-frequency work.

WILL—Is there any difference between a diode detector circuit in TV and radio?

KEN—Not a bit! Take a look. The r.f. (or i.f., if you like) voltages across coil L are applied to the diode (crystal or tube). It is connected in series with load resistor R, which has capacitor C across it. The alternation that makes the cathode positive cannot get through. But the next alternation, the one that makes the cathode negative, permits current to pass to the anode in the direction of the arrows. . . .

WILL—But why do you say that current flows when the cathode is negative? You have the plate marked negative here.

KEN—When the cathode is more negative than the anode, electrons can flow across the vacuum in the tube, or through the surface barrier in the crystal. You know that. These electrons are supplied by the voltage induced in L. Since the top end of L is the most negative point in the circuit, any current flow will make the bottom of the resistor more positive than the top. Electrons are being drawn away from it by the positive lower end of L, if you like. When the top end of L is positive and the bottom negative, no current can flow through the diode or R, so the polarity isn’t changed.

WILL—Then if we represent our modulated r.f. signal in the usual way, as you have here below the circuit, the detector blots out everything above the horizontal zero axis and lets only the negative alternations go through, and even these r.f. alternations lose their identity and are combined to produce the video signal by the accumulative action of capacitor C.

KEN—I see you haven’t forgotten much of what I taught you about radio not so many years ago. But notice now that instead of passing the negative alternations, we could just as well use the positive ones. All you have to do is turn the diode around.

WILL—That would be silly! Then your maximum video signals would be produced by the most positive voltages. If you applied signals like that to the picture-tube grid, you’d get blacks where you should have whites—a negative image!

KEN—Perfect reasoning! And if you intend to use the signal from the detector direct on the pix-tube grid, you’ll have to use negative polarity. But we usually have one or two stages of video amplification between the detector and the picture tube. The detector doesn’t put out enough voltage to modulate the cathode-ray spot from a good white to a good black. Now, an amplifier stage reverses the phase of a signal applied to it—what comes in as a positive pulse to the grid becomes a negative one at the plate, and *vice versa*.

WILL—I can finish the story now. If you have one v.f. stage, you need positive polarity. But if you have two, you need negative.

KEN—Exactly! But remember you can change your signal polarity another way. You can apply a *negative* voltage to the control grid of your cathode-ray tube, or a *positive* voltage to the cathode, which makes the grid rela-

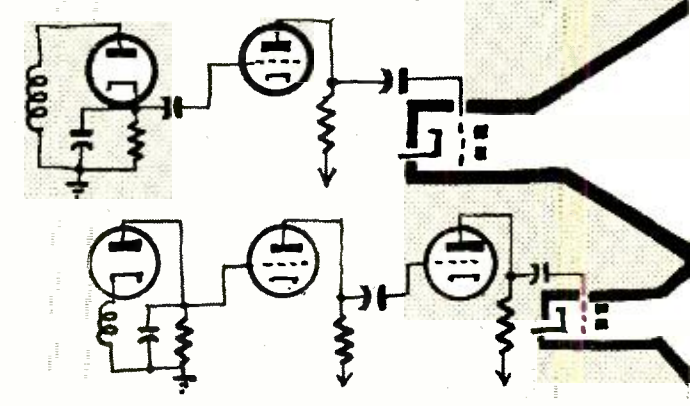
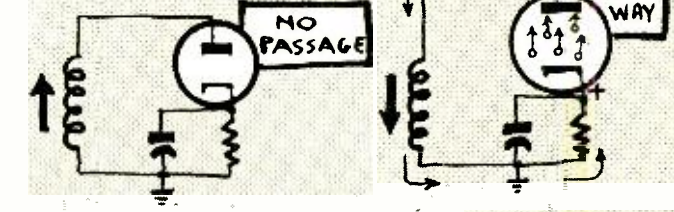
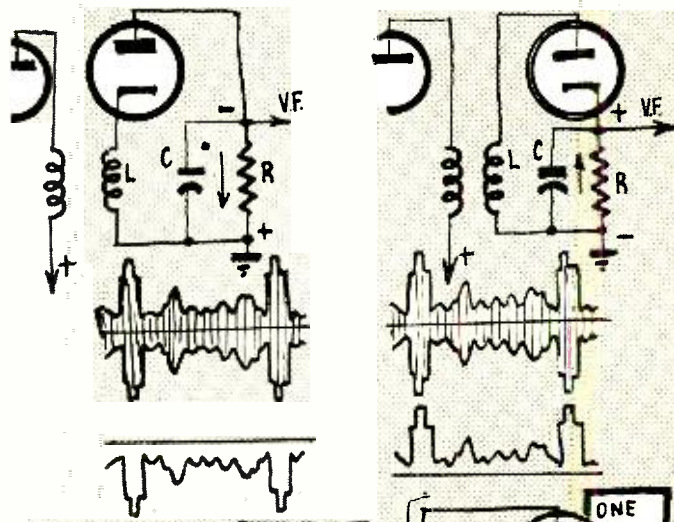
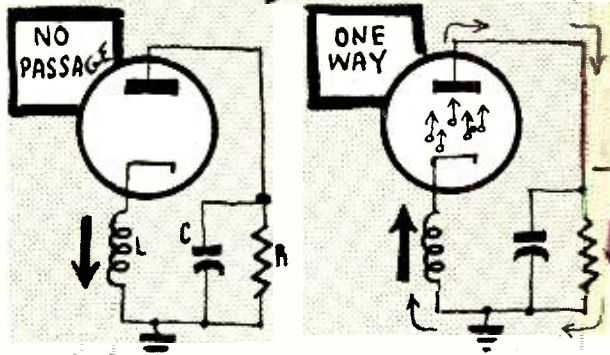
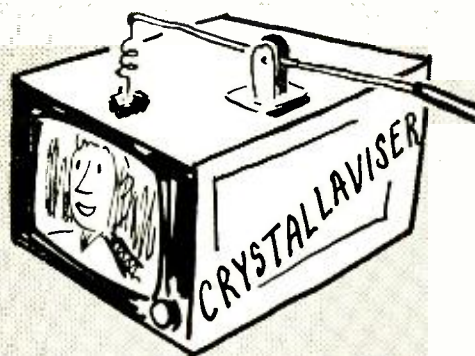

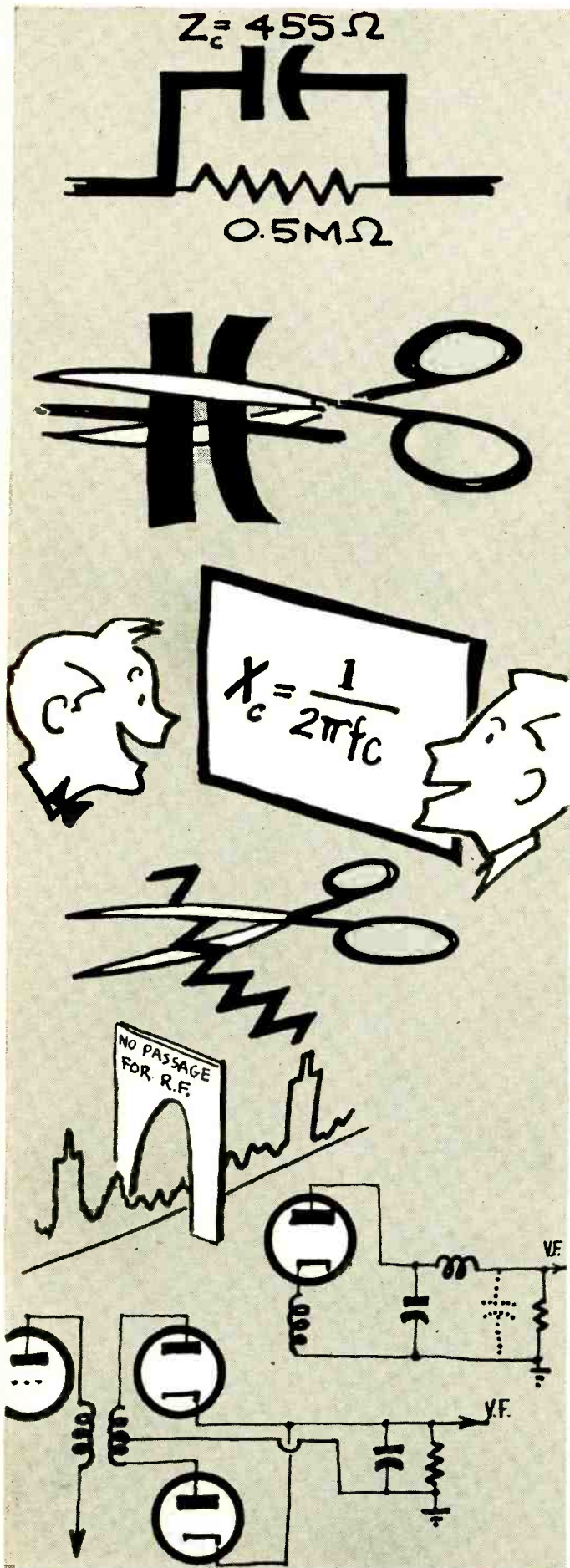

tively more negative. So, if you have the wrong polarity at the picture-tube grid, it may be easier to redesign your circuit to apply the signal to the cathode than to add another video stage.

WILL—Then, with polarity injection, we'd use negative detection for one stage and positive for two.

Sudden drop of values

KEN—You seem to have it, Will. Now let's try to figure out the values of capacitor C and resistor R in the detector circuit.

WILL—Well, I suppose we can still use our standard values of one hundred μf and a half megohm, just as in radio?

KEN—Oh, you think so? Well, now, just remember that the current you're detecting is alternating at a frequency not far from 50 megacycles a second. And the detected video voltages can run up to 4 mc. What reactance would your little one hundred- μf capacitor offer to 3.5 mc, for example?

WILL—Let me calculate—why, only a little more than four hundred ohms!! Is that possible?

KEN—It's probably correct. Now, how do your 400-odd ohms compare with the half-megohm resistor?

WILL—It would be practically shorted. You'd get practically no voltage across resistor R, and no signal into the video amplifier.

KEN—You're getting just a little too quick again! Certainly the lower video frequencies would get through with practically no attenuation. But the higher frequencies would be attenuated, and you'd get a picture with little or no fine detail.

WILL—Well, let's cut down the capacitor till it has enough reactance for the higher video frequencies.

KEN—That's just what has to be done. But you can't go too far in that direction either. The capacitance of C must remain considerably higher than the cathode-anode capacitance of the detector diode, if the greater part of the detected voltage is to appear across the terminals of C and R. So we use a capacitance of 10-20 μf . Some sets omit it entirely, and leave the job to the various wiring capacitances.

WILL—That would be economical, anyway. But it seems to me that the reactance would still be a little low compared to R.

KEN—Yes, you have to cut that down, too. Most sets use 3,300 or 3,900 ohms.

WILL—I suppose with a load resistor as small as that, the detection efficiency would take quite a drop, too?

KEN—Well, even in radio we're a long way from getting 90% of the detected voltage. But by using special diodes designed for television, which have very low internal resistance as well as low cathode-anode capacitance, we can apply a good part of the detected voltage to our video amplifier.

WILL—So the circuit will be the same as in radio, but the values will be much smaller?

KEN—Well put! And you'll see a filter to bypass the residual r.f. much more often than in radio—present-day radio, at least.

WILL—Why, that filter looks just like the low-frequency filter in a power supply!

KEN—Nothing strange about that, Will. Both circuits are designed to get rid of a higher frequency than the one to be passed. So in both cases you use inductors to block the higher frequencies, and capacitors to give them an easy path to ground.

WILL—Well, since this filter looks so much like part of a power supply, couldn't we go even further and make our detector a double-diode affair, to give full-wave rectification?

KEN—Your idea would no doubt work perfectly, and—if you had a suitable balanced input transformer—the circuit would be more efficient than a single diode. Filtering would be easier, too, same as at 60 cycles.

TO BE CONTINUED

BRITISH TV STANDARDS

By EDWIN N. BRADLEY

THE British system of television transmission, using 405 lines at 25 frames per second, must seem to many American technicians to be relatively coarse in definition. In practice, the picture obtained is very pleasing on a 27-inch tube, and at an adequate viewing distance even a 3 x 4-foot projected picture is perfectly satisfying.

For correct response to the transmitted information the receiver pass-band should be 2.7 mc, so that the design of single sideband apparatus is relatively simple. The channels in use are the original London channel of 45 mc (with double sideband transmission), together with almost national coverage from various points on 51.75 mc, 56.75 mc, 61.75 mc and 66.75 mc, single sideband. In each case the AM sound carrier is located 3.5 mc below the video carrier. Transmitter powers are high; the four latest stations operating at 50 kw (output—not effective radiated power). Vertical polarization is used at the main stations. Small stations covering specified areas use horizontal polarization and share distant transmitter channels.

At present all channels radiate the same program except for occasional local transmissions such as those in Welsh from the Cardiff station. In the near future it is intended to establish a further chain of semicommercial stations giving an alternative program.

A combined radio-TV license costs £2 yearly (\$5.60).

A particular advantage of the British system of only one channel in any area is that it enables simple receivers to be designed and built by the home constructor. Even a t.r.f. circuit with no more than 3 r.f. stages can give a very good account of itself. The simplest commercial set is arranged along the lines of the Baird *Everyman* receiver, containing no more than 12 tubes, including the picture tube. This has tricked some visitors to Britain into thinking that British receiver design is overelementary and lacking in various points. The reverse is actually true; there is no lack of high-gain televisions of the superhet variety with flywheel sync, and the like.

Home construction of televisions is remarkably popular not as an economic necessity but as a hobby. Circuits and components are obtainable everywhere for both simple and advanced designs. The final alignment of such receivers is almost always carried out on a transmission of Test Card C, which has become as familiar a picture to the British viewer as Muffin the Mule.

Test Card C, transmitted for 3 or 4 sessions of 15 minutes in the morning and as a tuning signal before the com-

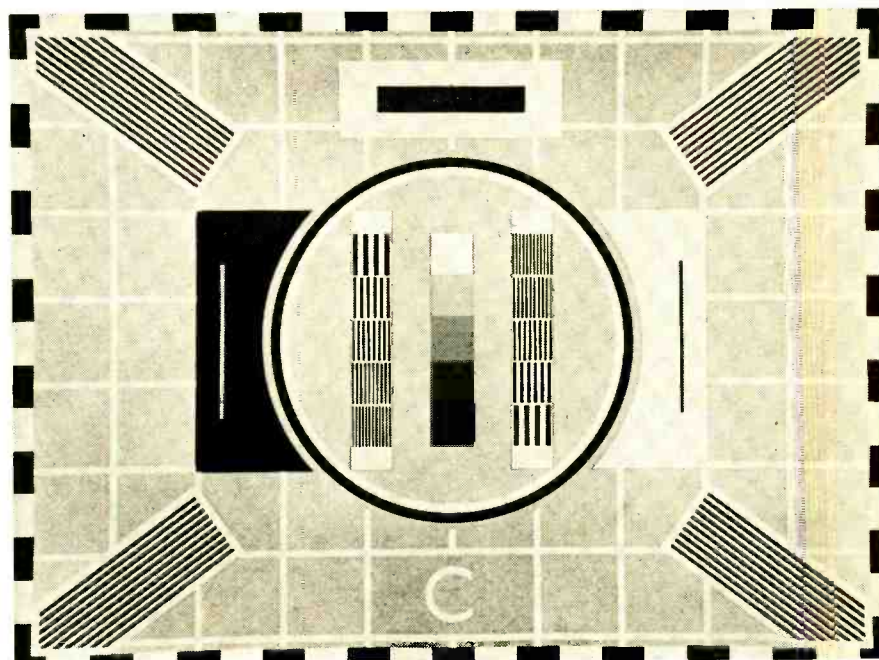

mencement of programs, enables a close examination to be made of receiver performance.

1. Aspect ratio test.

The central concentric black and white circles appear truly round when the aspect ratio is adjusted to the correct value of 4 : 3. The black and white rectangles along the borders of the card should then appear framed by the mask, and if the mask is out of true (which it rarely is) the viewer will generally demand a correction in no uncertain terms.

2. Definition and bandwidth tests.

Within the circles are a pair of frequency grating sets, made up of black and white stripes. These correspond to fundamental frequencies of 1, 1.5, 2, 2.5, and 3 mc, the 1-mc grating appearing at the top of the left-hand set and at the bottom of the right-hand set. Since the response of the system should be 2.7 mc, the 2.5-mc grating should be clear and distinct. Many receivers give a clear 3-mc response.

3. Contrast test.

A contrast wedge of 5 steps is displayed in the center of the card. The top white square corresponds to 100% modulation and the bottom black square to 30%. Positive modulation is used with the sync signals falling in the under 30% or blacker-than-black section of the modulation envelope. With the brilliance controls setting the top and bottom steps to white and black, the intermediate steps should appear as light, medium, and dark grey.

4. Scanning linearity test.

The background of the test card is a medium grey with a set of white

lines. These lines should be so reproduced as to make each enclosed area an equal square.

5. Synchronization test.

The black and white border of the card gives an excellent test of the sync separator stages. Faulty synchronization is immediately seen as tearing.

6. Low-frequency response test.

The black rectangle on a white background is designed to show up any failing in low-frequency response, and should be displayed as a clean-cut rectangle of uniform blackness on a clean background.

7. Reflection and ghost test.

Ghosts due to the signal reaching the aerial or in the receiving system itself are revealed by the two narrow vertical bars on either side of the circles. These should be reproduced without positive or negative images along their right-hand sides.

8. Focus test.

The diagonally inclined areas of black and white stripes at the corners of the card correspond to a fundamental frequency of about 1 mc and the four areas should all be in uniform focus.

The letter C is purely an identification, Test Cards A and B having been used previously. Test Card C is now a tried and trusted friend, however, and even has its fans. In the morning it always appears with its own familiar recorded musical selection, and one small boy, it is reported, in bed with measles, asked couldn't he have Tess Can't See' because that was the only thing that didn't hurt his eyes. It is presumed that he will grow up to be a TV critic.

END

UNIVIBRATORS and

UNIVIBRATORS

The operation and application of interesting electronic circuits

FLIP FLOPS

By ED BUKSTEIN*

THE univibrator differs from the multivibrator in that one of the tubes is biased far enough negative to prevent free-running operation. In this stable state, one of the tubes conducts and the other is cut off. This condition will remain until a trigger pulse is applied. The cut-off tube will then conduct and the conducting tube will be cut off. After a length of time determined by circuit values, the circuit will again return to its stable state and remain there until another input pulse is applied. Since,

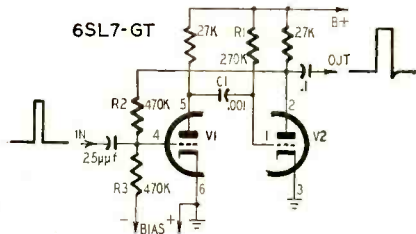

Fig. 1—A basic univibrator circuit.

for each input pulse, the univibrator is switched from its stable to unstable state and back again, a pulse waveform is produced at the plates of the tubes. The duration of this pulse is equal to the length of time the circuit remains in its unstable state. Since this interval is determined by circuit values and not by the input pulse, the output pulse duration and amplitude will be independent of the characteristics of the input pulse. The univibrator is widely used where pulses of random amplitude and width must be converted to uniform pulses. When used for this purpose, the circuit is also known as a *pulse equalizer*.

The univibrator circuit is shown in Fig. 1. V1 is cut off by applying a negative bias voltage to its grid, and

V2 conducts heavily since its grid returns to B plus. This is the stable state of the circuit. If a positive pulse is now applied to the grid of V1, the following changes will occur in the circuit:

1. The plate current of V1 charges capacitor C1.
2. The charging current of C1 produces an IR drop across R1.
3. The IR drop across R1 makes the grid of V2 less positive and drives it to cutoff.
4. When V2 goes to cutoff, its plate

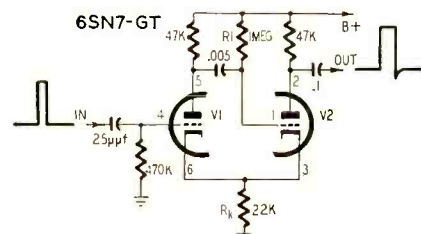

Fig. 2—Cathode-coupled univibrator.

voltage increases.

5. This increasing voltage is coupled to the grid of V1 through voltage divider R2 and R3.

6. The increase of voltage at the grid of V1 further increases the plate current in this tube. This action ends with V1 conducting heavily and V2 cut off.

7. As C1 continues to charge, the

IR drop across R1 decreases until it is no longer sufficient to keep V2 cut off.

8. V2 now begins to conduct plate current and its plate voltage decreases.

9. This decreasing voltage is transferred through the voltage divider to the grid of V1.

10. V1 becomes cut off and the circuit is back to its stable state.

The length of time the circuit remains in its unstable state (V1 conducting and V2 cut off) is determined by the charging time of C1. The time constant R1C1 therefore determines the width of the output pulse. Since the univibrator produces an output in response to an input pulse, it is sometimes referred to as a *one-shot multivibrator*.

In the univibrator circuit shown in Fig. 2, the second tube is coupled to the first by a common cathode resistor. Since V2 operates at saturation, it draws a large amount of plate current. The resulting IR drop across R_k is sufficient to bias V1 to cutoff. If a positive pulse is now applied to the grid of V1, this tube will become conductive. Its plate current will now cause C1 to charge through R1. The IR drop which now appears across R1 cuts off V2. As V2 ceases to draw plate current the voltage across R_k is no longer sufficient to keep V1 cut off. When the charging current of C1 has decreased to a value such that the IR drop across R1 is no longer sufficient to keep V2 cut off, the circuit returns to its stable state. Here again, the

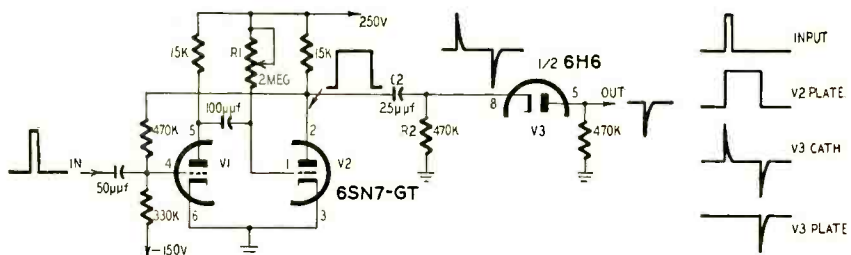

Fig. 3—The trigger-delay circuit is based on the univibrator.

*Northwestern Vocational Institute Minneapolis, Minn.

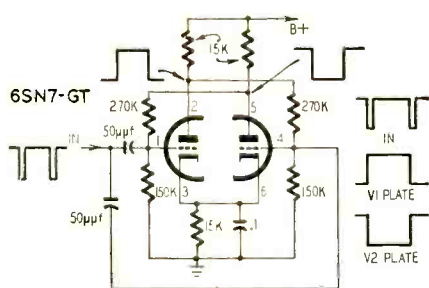

Fig. 4—The basic flip-flop circuit.

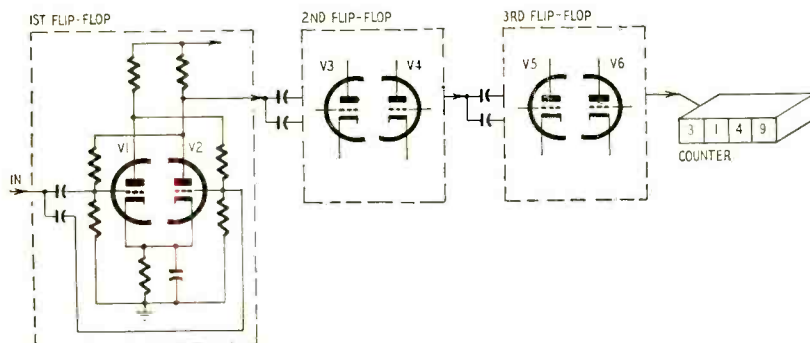

Fig. 5—Scaler circuit permits operation of electromechanical counter.

characteristics of the output pulse are independent of the input pulse. The advantage of the cathode-coupled univibrator is that it requires no negative voltage, simplifying the design of the power supply.

Univibrator applications

As a pulse equalizer the univibrator has been widely used to convert the random pulses of a Geiger or scintillation counter into the uniform pulses required to operate a counting-rate meter or a scaler. Another use of the univibrator is as a trigger-delay circuit. This is a circuit that produces an output pulse at a fixed, usually controllable, interval after the application of an input pulse.

In the trigger-delay circuit shown in Fig. 3, V1 and V2 are connected as a conventional univibrator. The pulse produced at the plate of V2, in response to an input pulse, has a width dependent upon the setting of variable resistor R1.

The pulse from the plate of V2 is applied to the differentiator network R2C2. The output of the differentiator consists of two narrow pulses, one positive and one negative. The positive pulse corresponds in time to the leading edge of the pulse from V2, and the negative pulse corresponds to the trailing edge. This relationship is shown in the waveforms of Fig. 3. The output of the differentiator is fed to a half-wave rectifier that passes only the negative pulse. Since this negative pulse coincides in time with the trailing edge of the pulse from V2, the time between the application of an input pulse to V1 and the production of an output pulse from the rectifier can be controlled by the setting of R1. The chief use of the trigger-delay circuit is to delay the sweep of an oscilloscope

so that it will coincide in time with the waveform to be observed. This technique is extremely useful in the study of transients.

The flip-flop circuit

Like the univibrator, the flip-flop circuit is not free-running and will switch only in response to an input pulse. Unlike the univibrator, however, the flip-flop has two stable states and can remain in either one indefinitely. Applying an input pulse will switch the circuit from its first stable state to its second. The next input

ferred through a voltage divider to the grid of V1, further reducing the plate current of this tube.

6. This action culminates with V1 cut off and V2 conducting.

If a second input pulse is applied to the flip-flop, the same action will repeat with the roles of the tubes interchanged, and the circuit will return to its first stable state.

Flip-flop applications

The flip-flop circuit is primarily used as a scaler. The scaler circuit is a frequency divider, i.e. it produces a pulse output whose frequency is equal to a submultiple of the input pulse frequency. It differs from the multivibrator frequency divider in that the input pulses can be applied at random. This is because the circuit can exist in either of its stable states indefinitely, a feature of extreme importance when used with such sources of random pulses as the Geiger counter. In this application, the scaler reduces the pulse frequency of the Geiger counter to a value sufficiently low to operate an electromechanical counter (Fig. 5).

In the first flip-flop of Fig. 5, V2 is conducting and V1 is cut off. A negative-pulse input (supplied by the Geiger counter) will reverse these conditions. A second input pulse will restore the circuit to its initial state. Since one complete cycle of operation of the flip-flop results from the application of two input pulses, the waveform at the plate of V2 has a frequency one-half the frequency of the input pulses.

The output of V2 is differentiated and applied to the grids of the second flip-flop. Here, the frequency is again divided by two so that the output of V4 has a frequency one-fourth that of the input pulses. Successive flip-flops provide output frequencies of 1/8, 1/16, 1/32, 1/64, etc.

The total pulse count is determined by multiplying the counter reading by the circuit scaling ratio. END

PARTLY PRINTED TV CHASSIS

A TV chassis built around a printed circuit features the 1955 line of Admiral receivers. The printed circuit contains six tubes and one-third the normally exposed wiring in the chassis. The circuits are photo-etched on sensitized copper plates. After all components, such as resistors, transformers, and capacitors, are assembled to the plate, it is dipped briefly into molten solder. The solder adheres to the etched circuit. In making service repairs, the leads of a component may be clipped off and used to "spot solder" a new component in place, eliminating extensive circuit rewiring.

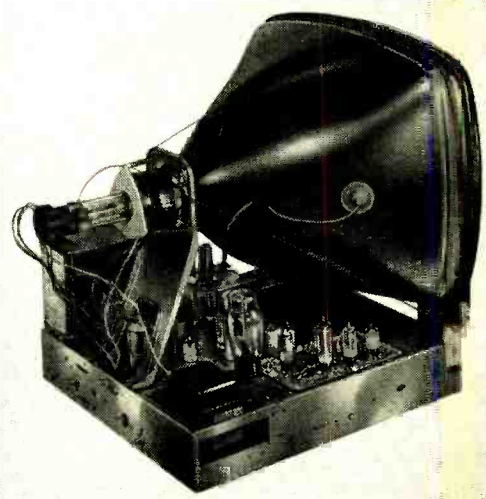

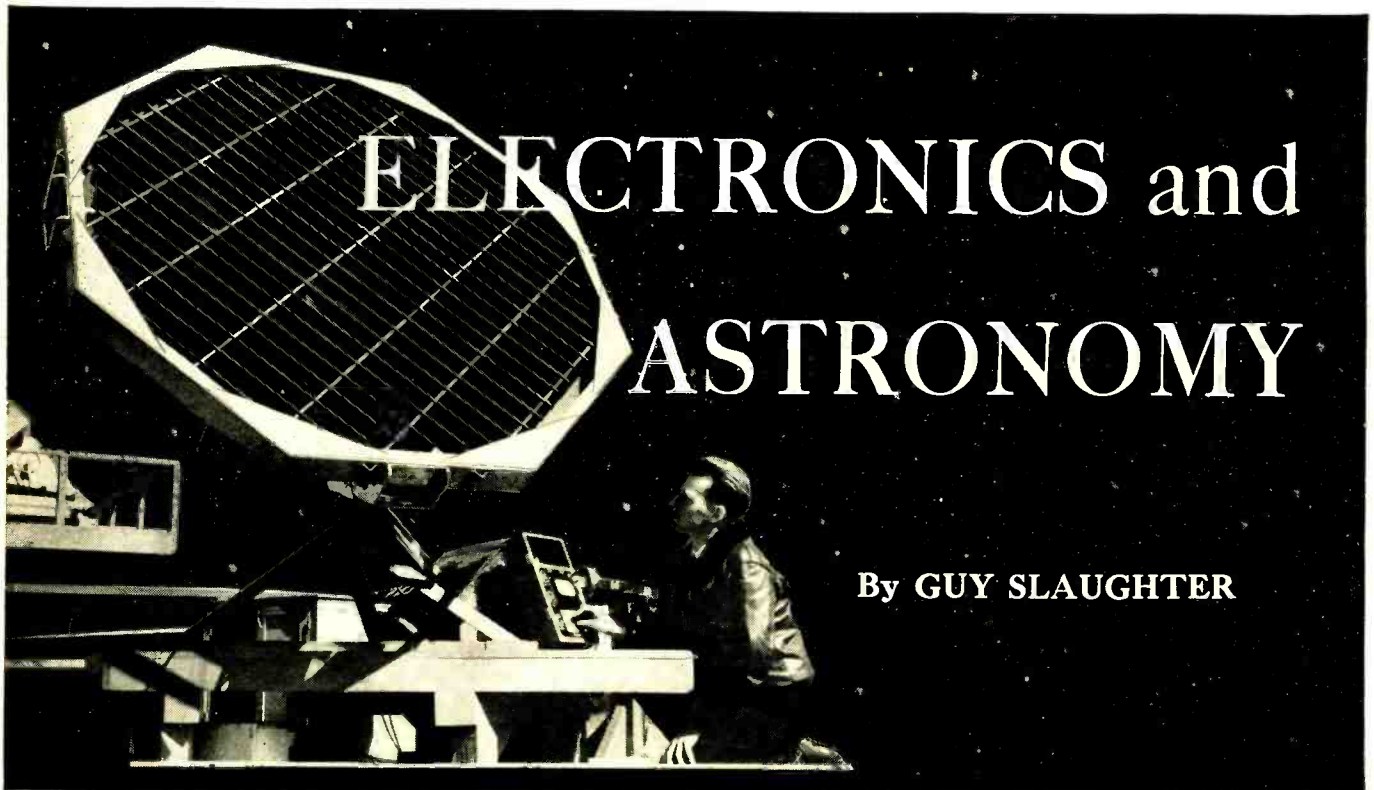

ELECTRONICS and ASTRONOMY

By GUY SLAUGHTER

4-foot reflector for 10.7-centimeter operation.

Photo courtesy National Research Council, Canada

WHILE astronomy is usually associated with optical instruments, modern observatories are crammed with electronic apparatus as well (Fig. 1). And while astronomy itself is perhaps the oldest of man's sciences, recent developments in the comparatively young field of electronics have become so important to the study of the stars that a whole new field of activity has sprung up. This new field is often called *radio astronomy*.

Professor A. C. B. Lovell, writing in the July, 1951, issue of *RADIO-ELECTRONICS*, has already called attention to one branch of this new alliance between astronomy and electronics: that of tracking the paths of meteors by radar. But there are many others.

Electronic controls

The ponderous mechanism of a multi-ton telescope must be arranged so it can allow the instrument to point at any spot in space. Once sighted on a star, it must follow that star across the heavens. Electronic controls are ideal for this application. The delicately balanced and almost frictionless telescope mount is driven, in a typical case, by a geared-down, fractional-horsepower synchronous motor. The motor is excited by the amplified output of an oscillator whose frequency can be varied within narrow limits. The gear reduction of the drive motor is such that, when it is excited at the oscillator's center frequency, it will

move the scope across the heavens at the same pace as the apparent rate of motion of the stars. Theoretically, once the scope is zeroed-in on a given star it will keep that star within its field of view for hours at a time, allowing long-exposure photographs of faint objects. Actually, however, even the most perfectly designed apparatus won't "freeze" the star for extended periods due to such phenomena as variable refraction of the star's light by the earth's atmosphere and slight twisting and bending effects within the telescope itself because of temperature changes. This is where the variable-frequency oscillator comes in. By altering the oscillator frequency slightly from time to time, the astronomer can keep the star virtually motionless within the scope's field of view.

Perhaps the most popular type of electronic drive uses an electromechanical oscillator (Fig. 2). It consists of a thin wire stretched between two anvils; a small piece of iron attached to the middle of the wire extends into the centers of two coils, a "driver" and a "pickup" coil. When the signal from one coil is amplified and fed to the other in the proper phase to maintain oscillation, the wire vibrates at a rate dependent upon its tension. A signal is picked off and fed through an amplifier to a power stage whose output excites the telescope drive motor, producing a rate of motion in the instrument which is dependent on the vibration-rate of the wire system. This

the astronomer controls by increasing or decreasing the current flow through an electromagnet whose field contributes to the tension on the wire.

Photometry

Another phase of astronomy in which electronics plays an important role is photometry. At one time the intensity of light arriving from a star or other celestial body was either estimated or compared visually with a standardized source. But now the image density of a photograph of the star is compared with that of an identical exposure of a standard star by a photoelectric "comparator." This instrument is a light-source-and-pickup device, with mechanical means for precisely positioning two negatives, in turn, between the light source and the photocell. The difference in cell current is proportional to the difference in star-image densities, and therefore dependent on the ratio of visual magnitudes between the unknown and the standard star.

The direct-reading photometer is also of great value to the astronomer. This device allows direct measurement of the intensity of light reaching it when its photocell is placed in the telescope's focal plane. Because of the extreme sensitivity of present-day photosensitive materials, the problem of measuring the tiny amounts of stellar light reaching a photocell is largely that of accurately measuring the resulting current flow. In a typical instance the incremental current flow from the

phototube's light-sensitive surface might be in the order of 1/50th of one billionth (2×10^{-11}) ampere. To accurately measure such minute changes, electron-multiplier phototubes are often used (Fig. 3). These tubes have, in addition to a light-sensitive surface, a number of anodes, each with a higher applied voltage than the preceding one. Electrons emitted from the light-sensitive surface of the cathode are attracted toward and impinge upon the first anode where, by secondary emission, they knock off several more electrons; these are attracted toward and strike the second anode, knocking off a whole cluster of electrons. The process is cumulative until, at the last anode, electron flow has been multiplied by a factor of perhaps a million, and hence current flow is large enough to be measured with the proper equipment. Often the photocell is refrigerated with dry ice to keep its dark-level output at a minimum, and is followed by a more or less conventional d.c. amplifier.

Closely allied with photoelectric photometry is stellar radiation measurement by thermocouple receivers. While many radiomen know that two dissimilar metallic strips joined at one end will generate a voltage proportional to the temperature of their junction, the use to which this fact is put in modern astronomical observation is almost spectacular. Previous articles in this magazine have pointed out the comparative simplicity of thermocouple temperature-recording devices used in industrial applications; here the tem-

perature-sensitive elements can be immersed in the molten metal or encased in a furnace, close to the source of the heat. But consider the astronomer's problem. He wants to measure temperature and temperature change on a distant planet, or perhaps on a tiny sun in some remote galaxy. What's more, he does it!

Actually his tools, except for the telescope, are basically similar to those used in industry. But they are used with greater finesse, and are considerably refined. While the industrial technician requires fair accuracy of metering temperature changes ranging from a few degrees to perhaps a few thousand degrees, the astronomer works with almost unbelievably small increments of thermometry. The temperature rise of a thermocouple receiver, for instance, induced by such a faint star (radiometrically speaking) as Boss 4342, is of the order of 9 millionths of one degree (9×10^{-6}) Centigrade.

A typical thermocouple receiver consists of two couples hooked in series-bucking, and often sealed off in a partial vacuum to increase sensitivity, with a tiny, blackened plate fused to each couple. The function of the plate is to provide an energy-absorptive surface upon which to focus the star image; the energy absorbed by the plate is conducted to the joint of the couple, and provides greater sensitivity than would be the case were it not present. The reason for the series-bucking arrangement is twofold: it provides a compensated circuit, so that

the no-light voltage generated by each couple is balanced out by the other; and it provides for twice the full-light output of a single couple, since—with a star image focused alternately on one and then on the other—total voltage output is opposite and therefore additive. The two couples are mounted side by side on a thumb-screw-driven stage which permits first one then the other couple to be positioned at the focus of

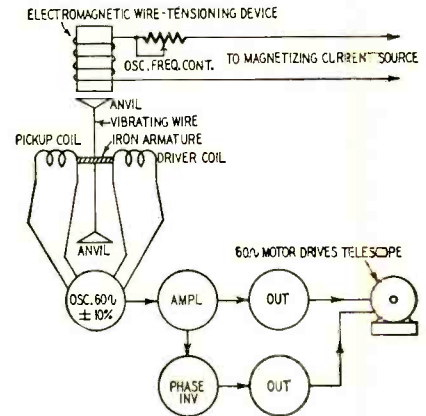

Fig. 2—Electromechanical drive.

the star image by a turn of the screw. It is a little-known fact that all the light energy reaching a thermocouple receiver contributes to its temperature rise, and not just the infra-red alone.

The current output of a thermocouple receiver is minute and requires special measuring techniques. The incremental current flow caused by starlight from Boss 4342 is in the neighborhood of one ten-billionth ampere. Meters for these tiny values fall into two general categories: galvanometric and electronic. As the names imply, the former is a sensitive galvanometer whose mirror is deflected by an amount proportional to the current flow through its moving coil; a light source reflected off the surface of the mirror registers its movements on a sheet of photographic film mounted several yards away, so that a tiny movement of the mirror causes considerable displacement of the light beam upon the film. The latter type of equipment consists of a high-gain d.c. amplifier whose output is either read on a meter in the plate circuit of the output stage, or recorded on a stylus-and-chart device similar to those used in industry for recording temperature-versus-time curves.

The radiotelescope

Perhaps the most interesting alliance between astronomy and electronics is radiotelescopy. A radiotelescope consists of a sensitive, broad-band receiver and a highly directional antenna pointing at the sky. Usually the antenna system is rotatable so that it can scan the heavens, and often takes the form of a parabolic reflector with a dipole at its focus. The radiotelescope at the Naval Research Laboratory in Washington, D.C., is of this type. Its reflector

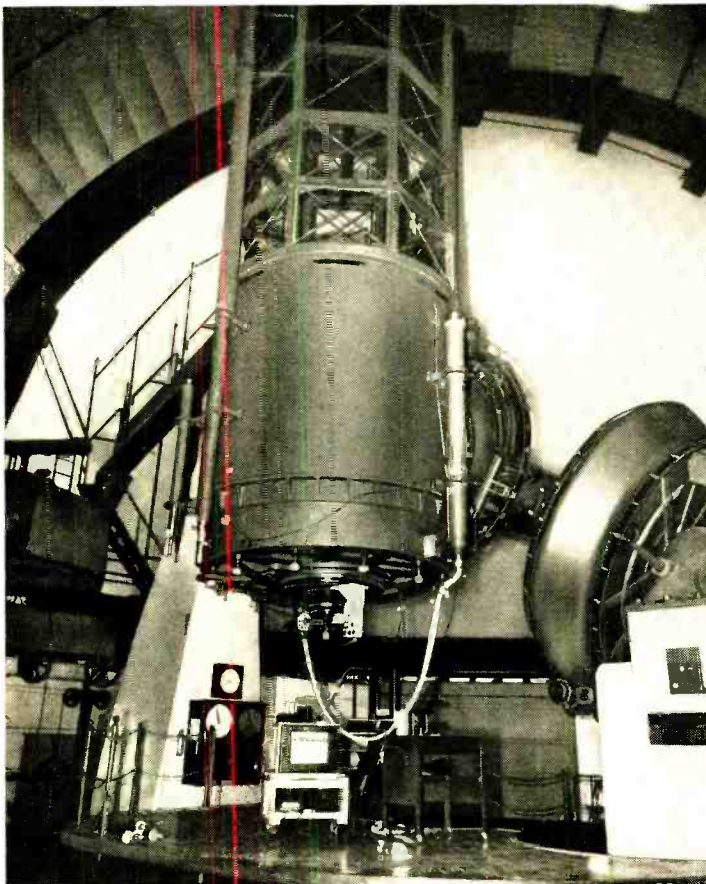

Fig. 1—Electronic installation in a modern astronomical observatory.

ELECTRONICS

is a 50-foot paraboloid of highly polished aluminum, arranged atop a gun mount so it can be rotated to point at any spot in the sky. Like its optical counterpart, the radiotelescope is usually fitted with a motor-driven positioning mechanism that not only simplifies aiming but also makes it possible for the scope to track the target automatically as it follows its path through the sky.

Though radiotelescopes are relatively new, the basic idea behind them originated with Sir Oliver Lodge in 1894. He suggested that since both light and heat are radiated earthward (and of course in all other directions) by our sun, it would seem logical that r.f. energy, or what he called "Hertzian

fixed the origin of this "cosmic noise" as somewhere in the Milky Way.

An amateur experimenter, Grote Reber, now with the Bureau of Standards, did a great deal of work at his home in Wheaton, Ill., starting in 1936; shortly thereafter an English group began investigations along the same line. All received signals from outer space, and all found the source of the radiations to be somewhere in the Milky Way.

Several theories attempt to explain this phenomenon of r.f. radiation from space, or more properly from clouds of spatial dust and gas. One school of thought supports the so-called "free-free transition" doctrine. According to it, an individual electron in its random travel through space occasionally comes within the region of influence of a free ion and alters its course to swing into an orbital arc around the ion; since this change in velocity amounts to a loss of energy, the "energy of transition" is radiated as r.f. Another doctrine states that interstellar space is occupied by tenuous hydrogen gas, and that the electron spin in an individual hydrogen atom reverses its direction occasionally and at random, about once in eleven million years for any given atom; it is the energy released during this "reversal" process that is radiated as interstellar noise.

Another noise source

A distinctly different, though not unrelated, source of signals from space has also been investigated by radiotelescope; particularly by a group of British scientists at Manchester, England. Using a 220-foot fixed (non-rotatable) antenna system, they found that certain classes of stars radiate detectable noise bursts. Because of the r.f. radiation they were able to locate previously unknown stars which, evidently, emit little or no visible light. About one hundred such radio stars have been charted, some of which would seem to be closer to us than *Proxima Centauri*, the closest known (that is, visually observed) star in the heavens. These same scientists found, too, that Sir Oliver Lodge was right. Our sun does radiate "Hertzian waves."

The British observers believe that radio stars are either too new or too old to be visible. They theorize that, since all warm bodies radiate energy the frequency of which is proportional to the temperature of the body, a not-yet red-hot or an already cooling star radiates energy within the r.f. spectrum though little or none within the visible portion of the band.

However spatial radiation originates, it is the function of the radiotelescope to detect the radiation and to indicate that pinpoint in space from where the signals originate. Like its optical counterparts, the *energy-gathering* ability of a radiotelescope is proportional to the size of its reflector; the larger the reflector the more *cosmic noise* it can gather and funnel into the

receiving antenna. But because of the longer wavelength of r.f. energy as compared to visible light, the resolving power, or pinpointing ability, is not nearly as good as with optical instruments. The minute imperfections in the physical figure of the directional reflector also affect its resolution. Most installations do not permit much greater accuracy than a bearing of perhaps half a minute of arc. But the Naval scope, with its machined aluminum reflector made up of 30 precisely machined sections, may be able to receive a beam only a few seconds of arc in width. So may the new British installation, with its 250-foot reflector, which to date is far and away the world's largest radiotelescope.

Microwave receivers

The Naval Research Station at Washington has not released any technical information concerning the microwave receivers used in its radiotelescope. However, conventional superhet receivers have proved satisfactory (Fig. 4). The main requirements are, of course, sensitivity and low inherent noise level.

Good results have been obtained with broadband receivers on each of several different parts of the spectrum. The Naval station works mostly on the 3-, 10-, and 30-centimeter bands. The British seem to favor 20 centimeters, though most of their early work was done on the comparatively low frequency of 64 mc. Bell Telephone Laboratories' Jansky was using 20.5 mc when he first ran across the *cosmic noise*. And Grote Reber, whose work contributed much to the present state of the art, used both 160 and 480 mc. The main advantage of the higher frequencies seems to be their freedom from annoyances such as manmade interference and atmospherics.

From the standpoints of frequency range, relative sensitivity, and bandwidth, it would seem that an ordinary commercial TV set, whether u.h.f. or v.h.f., might perform the receiving chore in a modest radiotelescope installation. It is a matter of speculation just what a cosmic noise burst might look like on the screen. But presumably it wouldn't appear too different from some of the noise patterns that viewers have grown accustomed to. In fact, who can say that some of these familiar noise patterns are not interstellar in origin?

In the near future look for a new hobby to spring up. Look for more and more experimenters to start exploring the possibilities of radiotelescopy!

And when they do, when sufficient numbers of amateurs start scanning the sky with TV sets or homemade receivers, their haywire directional antennas pointed heavenward, then radio astronomy, a new science born of a couple of older ones, will begin a rapid advance. It always happens that way.

Look what the amateurs did for radio! END

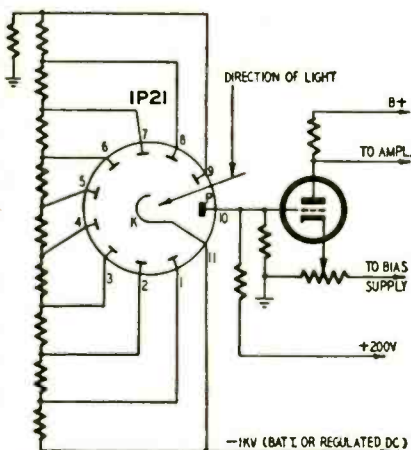

Fig. 3—Electron-multiplier circuit.

waves," should also form part of Sol's radiation spectrum, and should be detectable here.

Sir Oliver failed in his attempts to prove his theory experimentally, as did many workers after him. But in 1932 a research worker in the Bell Telephone Laboratories succeeded in intercepting radio signals from outer space. His name was Dr. Karl G. Jansky, and he was using a rotatable antenna system in an attempt to check the direction of arrival of thunderstorms with his receiving equipment. During the course of his investigations he heard occasional noise pulses that seemed to come from somewhere out in space. He finally

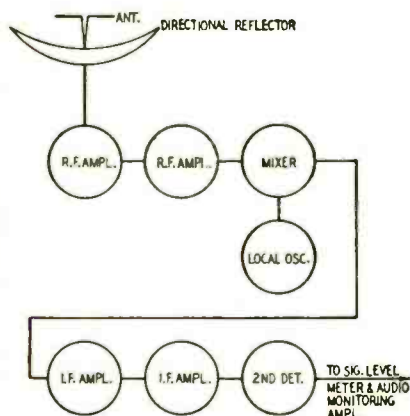
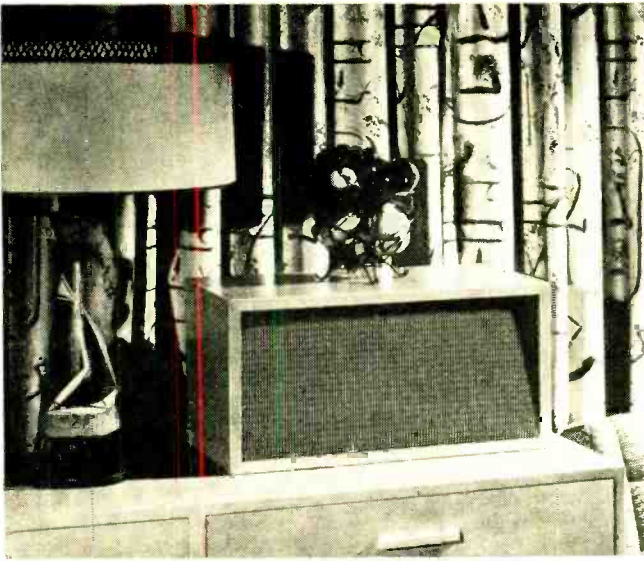

Fig. 4—Block diagram of radiotelescope. The receiver is fix-tuned.

WIDE-RANGE SPEAKER SYSTEM

By F. J. Van ALSTYNE*



The unobtrusive Diminuettes speaker enclosure in a typical environment.

NOT long ago high-fidelity music was a hobby enjoyed by relatively few well-to-do individuals. Today it is a form of home entertainment enjoyed by thousands. The broadening hi-fi market includes a great number of critical enthusiasts who must plan carefully the amount of space and money they can devote to their music system. The small apartment dweller is often offered a speaker system that far exceeds the capabilities of the rest of the components of his audio system. For the well-heeled hobbyist, the sky may well be the limit in both size and price. However, there is a great demand from thousands of hi-fi music lovers with limited space and budgets for a really good small-size speaker system capable of reproducing—cleanly and faithfully—the full range of frequencies recorded on the better LP records of today. This requires reproduction of fundamental frequencies down to 45 cycles on the low end and to 16,000 cycles on the high end.

Except for the few records that reproduce the very lowest organ tones, little recorded material exceeds these frequency limits. In fact, few sounds in normal human environment, aside from low-frequency wind effects (thunder) and low organ tones, have fundamental frequencies in the first octave (16 to 32 cycles). In the region between 32 and 45 cycles, an occasional recorded note may appear on a select few records, but it is also in this region that turntable rumble usually occurs, often completely masking any recorded material present. On the high end, hiss and other noises account for practically all of the output above 16,000 cycles.

Consequently, for moderately priced systems which do not incorporate an expensive professional-quality turntable, a speaker system with a frequency range of 45 to 16,000 cycles is not only adequate, but is sometimes preferable over speaker systems that exceed the capabilities of the other components.

*Permoflux Corporation, Chicago

1-WATT INPUT — Mike 3 feet away on Axis.

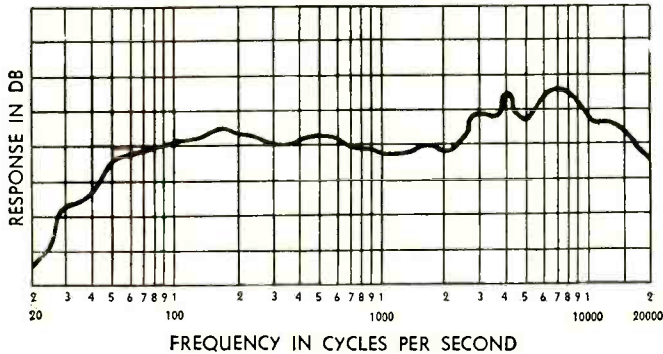

Fig. 1—Response curve of the system.

¼ WATT INPUT — Mike 18" away on Axis.

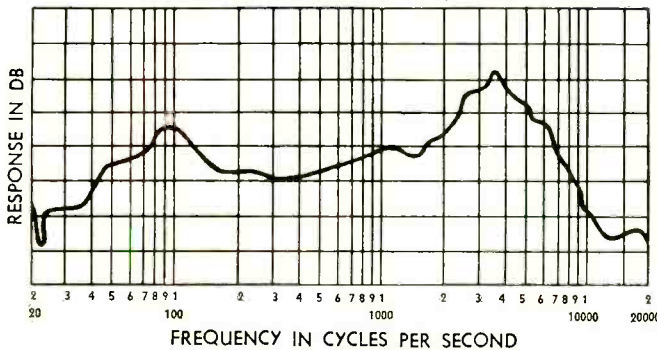

Fig. 2—Characteristics of the 6L-1.

¼ WATT INPUT — Mike 18" away on Axis.

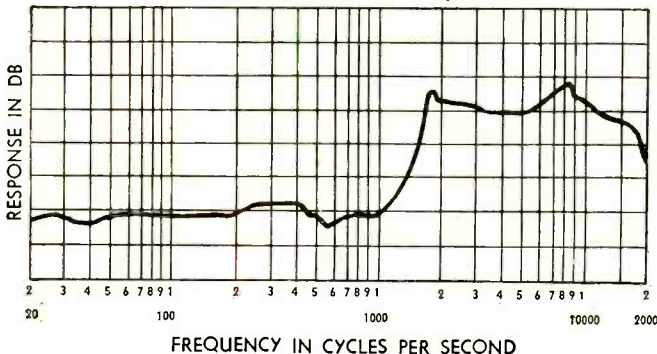

Fig. 3—The 32KTR tweeter's response.

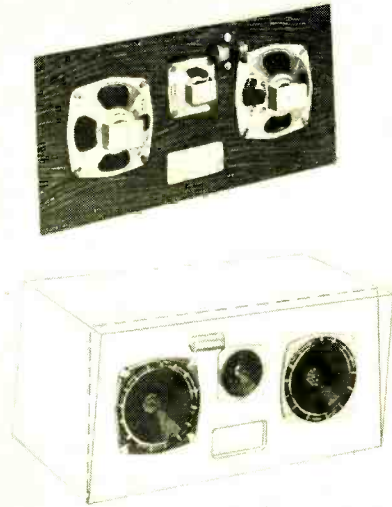

Fig. 4—The cabinet and speaker board.

The Permoflux *Diminnette*, shown in the photograph above and described in this article, is a speaker system of small size (23½ x 11 x 12 inches), designed specifically for use with hi-fi systems where the above frequency-range requirements apply. Its response characteristics—shown in Fig. 1—indicate that output is essentially constant over the range of 45 to 16,000 cycles, these being the points at which response is down 3 db. The 5-db-down points are 40 and 17,000 cycles. Measurements were made with a 1-watt-input level, simulating typical small room hi-fi listening conditions.

Fundamental design

By using one of the oldest and soundest principles of acoustic radiation, the *Diminnette* System achieves its wide-range performance with remarkably low distortion and at a very modest price. The fundamental principle of design is that of increasing radiation efficiency by employing the mutual coupling effect between two or more closely spaced radiators. This effect, properly employed, enables two identical speakers of small size to have higher radiation efficiency than a single speaker twice the size of either. At the same time, distortion and baffle volume requirements are reduced by the same factor due to the decrease in

electrical input and speaker cone excursion.

The real advantage of this principle is that baffle requirements for the multiple combination remain approximately the same as for one of the small speakers, permitting great reduction in speaker cabinet size. This principle has not been more widely employed in high-fidelity speaker systems to date possibly because of the impressive appearance of the large enclosures required properly to load the big speakers commonly used. These enclosures can be a very handsome piece of furniture and impress the uninitiated by their sheer size. However, hi-fi has now spread to the multitude of people who are more interested in fitting their system unobtrusively into their living-room (and budget) than in acquiring a new and bulky piece of furniture.

Since a free-space cone resonance as low as possible was desired, the system uses two special 6-inch speakers (Permoflux model 6L-1) with slotted, plastic-impregnated outer cone suspension, for low and midrange reproduc-

tion. As the curve of Fig. 2 shows, the resonance of this speaker occurs in the 80-cycle region. A specially designed cone type tweeter (Permoflux model 32KTR) was employed for the high frequencies. Response of this unit is essentially flat from 2,000 to 16,000 cycles (Fig. 3). A high-pass filter cuts in the tweeter in the 3,000-cycle region, taking advantage of the excellent mid-range characteristic of the 6L-1 speakers and limiting the tweeter to the frequencies for which it was designed.

Laboratory tests disclosed that when the two 6-inch speakers were spaced 6 inches apart, in a bass-reflex enclosure of less than 2 cubic feet volume, radiation efficiency was approximately equal to that of a 12-inch speaker in a 6-cubic-foot enclosure!

To aid both in lowering and damping the cabinet resonance, the speaker mounting board is tilted back about 7° from the perpendicular (see Fig. 4). This lengthens the reflected sound path by directing it around the cabinet and breaks up direct back-wave reflections between the back of the cabinet and

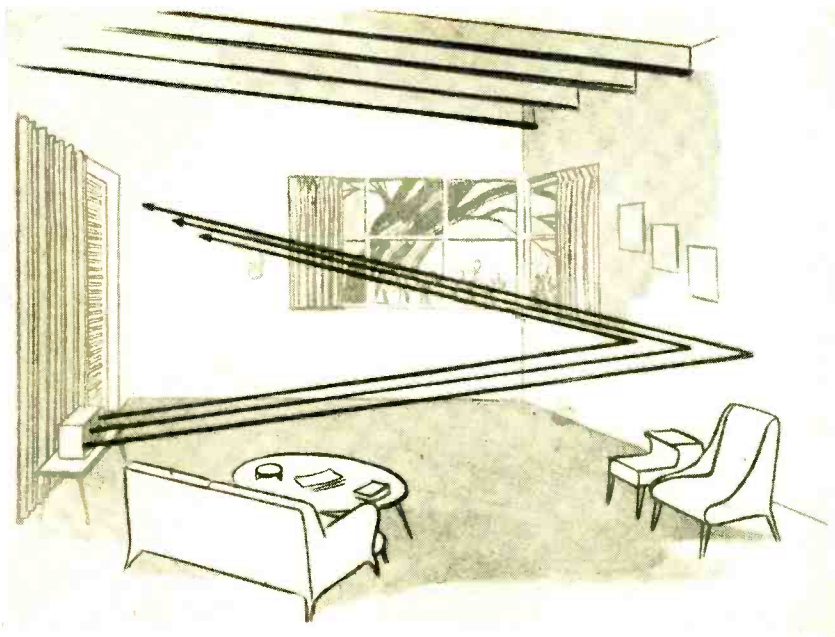

Fig. 5—Angled speaker disperses sound.

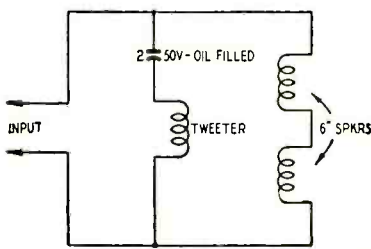

Fig. 6—How the *Diminnette* is wired.



One of the Permoflux 6L-1 speakers.

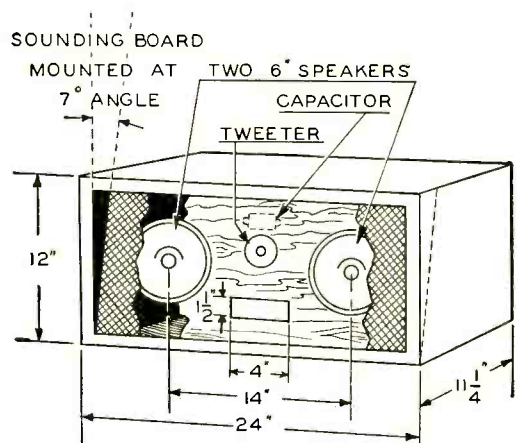

Fig. 7—Design details and dimensions.

Distributed Capacitance Nomograph

the speakers. The tilted speaker mounting board is also beneficial when the speaker system is placed in the listening room. The upward slant directs sound directly toward ear level when the equipment is placed near the floor, as when used on the lower shelf of a bookcase. When placed on a mantle or other position well above seated ear level, the enclosure can be inverted to direct sound down toward the proper listening level. Fig. 5 shows how the angled speaker mounting board also prevents distortion due to direct reflections from walls and disperses sound around the room, much as it is reflected around a concert hall.

The electrical hookup of the system is a series-parallel arrangement (Fig. 6) with the two 3.2-ohm 6-inch speakers connected in series and paralleled by the 16-ohm tweeter with its series capacitor (2 μ f, 50 volts, oil-filled). The 6-inch speakers are so phased that both cones move in the same direction when a d.c. voltage is applied to the input terminals. This parallel combination results in 6.2 ohms impedance at the customary 400-cycle measuring point and makes the system suitable for matching to the 8-ohm output of high-fidelity amplifiers. The 6.2-ohm impedance also makes the system suitable for replacing the 3.2-ohm speaker of television sets and FM radios. The small amount of power loss due to the slight mismatch is more than compensated for by the high efficiency of the system. The improvement in sound quality obtained by substituting the Diminette for the set speaker is rather startling and well worth the modest investment of \$49.50. This versatile system can be used—with a simple switching arrangement—for both hi-fi listening and TV sound improvement.

The impedance arrangement which places the 6.4-ohm series impedance of the two 6-inch speakers in parallel with the 16-ohm tweeter and 2- μ f capacitor combination was chosen to attain a proper balance between high-end and low-end response. The power distribution resulting from the different impedances in the two branches of the system results in nearly perfect blending of highs and lows and makes a balance control unnecessary. Any minor variations—to suit individual tastes—can be made by slight adjustment of the amplifier bass and treble controls.

The Diminette enclosure is constructed of 3/4-inch lumber core plywood to prevent cabinet vibration, and lends itself very well to home assembly. Construction details are shown in Fig. 7. Material should be 3/4-inch plywood for top, bottom, and sides; 1/2-inch plywood for back and speaker mounting board. However, it may be desirable to purchase the unit complete, since the three speakers and filter capacitor account for \$27.40 of the total cost. This leaves only \$22.10 for cabinet construction.

END

A FREQUENTLY used method of determining the distributed capacitance of a coil is to resonate the coil with a calibrated capacitance at a convenient frequency and at the second harmonic of that frequency. Q meters and coil checkers are used for this measurement since these instruments contain a calibrated capacitance, resonance indicator, and variable frequency generator. When resonating at the first frequency, it is desirable to use a reasonably large setting of the calibrated capacitor. At twice this frequency the combined distributed and calibrated capacitance will be one-fourth. When using the double-frequency method, distributed capacitance can be calculated from the formula

$$C = C_1 - \frac{4C_2}{3}$$

in which C1 is the resonating capaci-

tance for the lower frequency, and C2 is the resonating capacitance at the second harmonic.

The nomograph has been designed to solve this formula. To use the nomograph, select the value of C1 on the C1 scale and the value of C2 on the C2 scale. Join these points with a straight line. At the intersection of this line with the C scale, read the distributed capacitance.

As an example, determine the distributed capacitance for a coil resonated with 200 μ f at the fundamental and 35 μ f at the second harmonic. Draw a straight line from 200 on C1 to 35 on C2. At the intersection of this line with C, read 20 μ f.

Determining distributed capacitance will be particularly useful to technicians working and experimenting with high frequencies.—Joseph F. Sodaro

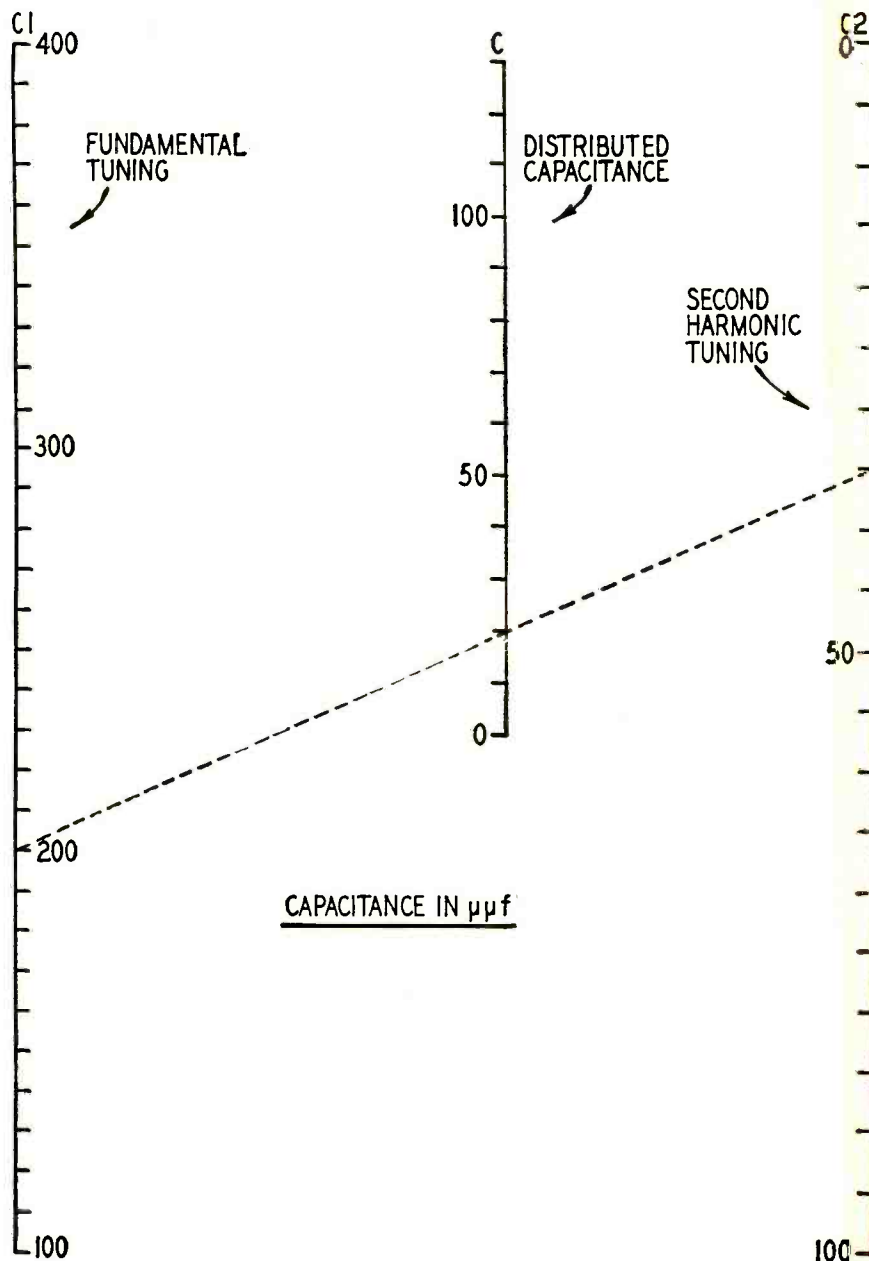

HIGH-QUALITY AUDIO Part XIV

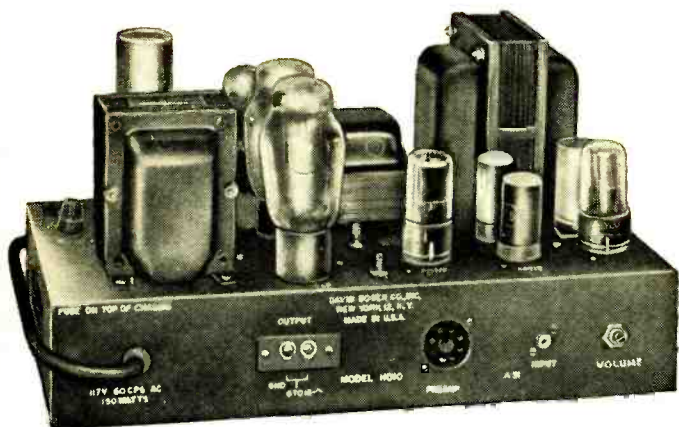

A typical high-quality audio amplifier, the Bogen HO10, with its preamplifier.

By Richard H. Dorf*

Negative feedback and its effects on noise, distortion, and frequency response

NEGATIVE feedback (and sometimes positive feedback) is one of the principal features which distinguish a high-quality amplifier from one used in old-style radio-phono combinations or in ordinary radio receivers. The sound quality of which an amplifier is capable depends, to a certain extent, on how much feedback is used—and how much can be used depends in turn on how well the amplifier is built before feedback is added. The effects of feedback are strictly dynamic in nature: that is, when operating without an input signal or an output load, amplifiers with and without feedback look, measure, and are the same.

Negative *voltage* feedback, the type usually found, accomplishes these things:

1. It reduces distortion.
2. It reduces noise originating within the stages covered by the feedback loop.
3. It lowers the effective output impedance of the amplifier so that the speaker damping is improved.
4. It reduces amplifier gain but not the output power capability.

Let us see first how feedback reduces noise. Fig. 1 is a block-type diagram of an amplifier and its terminals, plus a negative feedback connection. The negative feedback connection takes a portion of the output from a voltage divider across the output and feeds it back into the input of the amplifier. It is important that the phase of the fed-back output be *opposite* to that of the input. To illustrate that we have shown in Fig. 2 a sample input signal (a sine wave) and the resulting output signal; note that the two are 180° out of phase. In practice this is just a matter of reversing the output transformer connections if the phase relationships are not correct.

*Audio Consultant, New York

Now let us suppose that the illustrative signals we have shown are not present—no input to the amplifier. However, somewhere within the amplifier there is a hum. Let us say it is due to pickup by a grid lead in an a.c. field. (We have to be careful here—some types of hum are *increased* with negative feedback!) The output signal from the amplifier caused by this internally generated hum is shown as wave A in Fig. 2.

Because of the feedback connection a portion of the hum voltage is fed back to the input of the amplifier. It goes through the amplifier just as any input signal would and it emerges at the output in *opposite* phase to the original hum output. This new output resulting from the hum voltage being re-fed through the amplifier is shown as wave B in Fig. 2. One glance makes clear that the two waves A and B tend to cancel and produce wave C, which is the very much smaller resultant of the two and is the final hum voltage actually at the amplifier output.

It should be obvious that this kind of reduction through cancellation caused by negative feedback applies to any kind of signal originated *within the amplifier*—impulse noise, shot effect, thermal resistor noise, hum picked up by proximity to a power line or transformer, and so on.

It also applies to any signal purposely connected to the amplifier input. Suppose that wave A in Fig. 2 represents a recorded flute note coming from the preamplifier to the amplifier. It passes through the amplifier, producing an output wave opposite in phase to the input wave. Part of that is fed back to the input through the feedback connection, which results in a second output signal B opposite in phase to the first. The two tend to cancel, so that the result net output C is less than it would be if there were no feedback.

Then, how is noise in the amplifier

reduced by negative feedback, since the signal is reduced in the same proportion? The answer is that we can now *raise* the level of the input signal to have again the same output level we had before applying feedback. The level of the noise within the amplifier is *not* raised, however, so the total effect is that the noise is reduced to a much smaller percentage of the signal than before feedback was introduced.

This shows how negative feedback reduces amplifier noise, but it leaves one paradox. In Fig. 2 we showed wave B, representing the output resulting from the fed-back hum, smaller than wave A, representing the original hum output. Suppose we had a high-gain amplifier and instead of using a

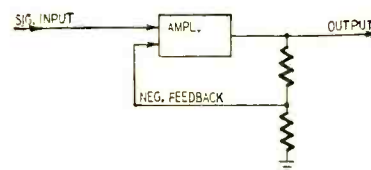

Fig. 1—Fundamental negative feedback.

voltage divider we applied *all* the output back to the input. Could not B be considerably bigger than A, resulting in an actual increase in hum?

The answer is no. Again—as in an earlier chapter with respect to the “self-balancing” phase inverter—we must cite the rule that a self-correcting system must have some error, else there is nothing to cause a correction. Suppose B were exactly as big as A. Then net output hum would be zero. But if output hum were zero, there would be no hum voltage to feed back to the input. And if we fed back no hum to the input, there would be no output wave B to cancel the original hum output A!

Obviously, then—and this is a good thing to remember—no matter how

much we increase negative feedback, the net gain of the amplifier can never be reduced to zero and output can never be zero (full cancellation) as long as there is any noise generated internally

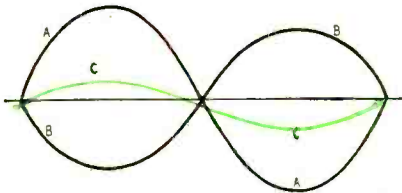

Fig. 2—How the feedback reduces noise.

or any signal applied to the input. This is true only as long as the feedback is negative—reversed phase between input and output. If it is positive, we simply have an ordinary oscillator whenever the amplifier gain is 1 or greater. Negative feedback certainly can, however, be increased to the point where the amplifier gain is less than 1—that is, where the output signal is less than the input signal.

Distortion reduction

Based on what we have just said, the distortion-reducing action of negative feedback can be very simply explained in words. Signals originating within the amplifier can be reduced with respect to signals introduced at the input. Distortion consists of intermodulation products and harmonics, frequencies which did not exist in the input signal. *The distortion products must therefore have been generated in the amplifier* and are reduced in the same manner and at the same rate as hum, tube noise, and the like.

But such a simple statement does not give us any kind of picture of what goes on. Fig. 3 does give such a picture, and (in spite of its appearance) it is very easily explained.

Assume that the amplifier has a voltage gain of 2 from input to output—in other words $E_o \times E_i = 2$, with E_o the output voltage and E_i the input signal. This is without any negative feedback. The symbol for gain before feedback is A, so $A = 2$.

The fraction of the output voltage fed back to the input when we add negative feedback is 0.25, and the symbol for this fraction is β (the Greek letter beta); β is usually expressed as a percentage, so $\beta = 25\%$.

In Fig. 3 we show a triangular wave, since it is easier to draw accurately and easier to evaluate when reading. The wave E_i is the signal connected to the amplifier input. The amplifier gain (A) before feedback is 2; therefore the output wave E_o is twice the amplitude of E_i . Because we have the transformer connections phased for negative feedback, E_o is 180 degrees out of phase with E_i .

Note, however, that this amplifier is distorting badly. Evidently a couple of grids are so biased that both positive and negative peaks of the output wave are clipped off, and the resulting sound would be extremely irritating.

The percentage of output voltage fed back to the input through the voltage divider is 25. This is shown by the wave labeled βE_o , with a value equal to 25% of the output. At the amplifier input βE_o and the original input voltage E_i are added in series. They produce a resultant E_i' , which we obtain graphically by adding algebraically the positive and negative amplitudes of the two at each point along the horizontal axis. E_i' is now the *effective amplifier input voltage*, even though the actual signal fed from the oscillator or whatever the source may be has not changed.

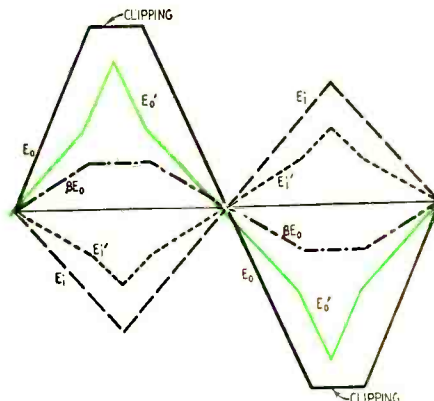

Fig. 3—Distortion reduced by feedback.

E_i' now goes through the amplifier. Notice that E_i' has a different shape from either E_i or E_o . E_i' goes through the amplifier and is subjected to a gain of 2, so that the new output E_o' is as

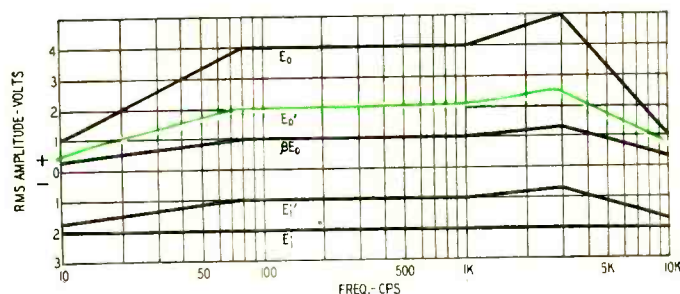

Fig. 4—Effect on frequency response.

shown. The new, effective amplifier output is still a distorted wave; but it comes a great deal closer to matching the shape of the input E_i than the original output E_o did, and will not sound nearly so bad.

Several inferences can be drawn from all this. First, it is not satisfactory simply to build an amplifier without regard for distortion and then look to negative feedback to clear it up. Feedback has a very salutary effect, but it is obvious from Fig. 3 that the less distortion there is in the first place the less there will be after feedback has done its work.

Next, the larger the value of β , the more the distortion is reduced and the lower is the effective gain of the amplifier. Note that the effective output with feedback E_o' is a good deal smaller than E_o without feedback.

Third, the same philosophy ought to work for improving frequency response—and it does! Suppose an amplifier without feedback has a large peak around 3,000 cycles. Since the voltage fed back to the input equals the output multiplied by a constant factor β , more voltage will be fed back at 3 kc than at other frequencies, it will have more cancelling action, and will cause less resultant output.

In Fig. 4 we have shown frequency curves on a plus-and-minus scale to indicate two phases. E_i is the input voltage and has the same amplitude at all frequencies—obtained for this test from a good signal generator. Again the nominal gain is 2, so the output E_o is at 4 volts over the mid-range. But it has a bass droop, a 3-kc peak, and treble droop.

We apply 25% of E_o back to the input as βE_o . Next we see that adding E_i and βE_o algebraically produces a resultant E_i' . (Note carefully that the amplitudes of E_i' are maximum when the curve drops and minimum when it rises since we are using a two-phase scale reading both ways from zero; refer to the numerals at the left to make this clear.)

Now we pass E_i' through the amplifier, which has its gain of 2, and the result is the net effective output E_o' , in which the variations from flat are very noticeably reduced. A larger β and higher amplifier gain would flatten the curve still more, as we shall show.

Impedance reduction

Fig. 5 is a very unconventional-looking equivalent-circuit diagram which is an easy way to explain how the internal resistance of an amplifier (amplifier output impedance) is reduced by negative voltage feedback. The a.c. generator represents the amplifier, the final stage of which has a certain internal resistance R_{int} , and both can be represented by the zero-impedance generator and the resistance. The load may be

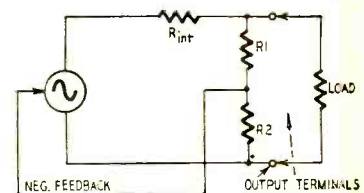

Fig. 5—Internal impedance reduction.

AUDIO—HIGH FIDELITY

a loudspeaker (fed through a transformer whose primary impedance is suited to that of the output stage). Ignore R1 and R2 for the moment.

If the load is opened, the full generator voltage appears across the output terminals. The moment the load is connected the generator current passing through the internal resistance causes a voltage drop across that resistance; then the voltage across the load is the generator voltage minus the voltage dropped across R_{int} . Obviously the bigger the internal resistance, the smaller the voltage appearing across the load. Obviously also, the larger the load resistance, the larger the voltage appearing across it.

Now let us add negative feedback, obtained from voltage-divider R1-R2 across the output terminals. Suppose we remove the load. The voltage at the terminals immediately becomes maximum—the full generator voltage—affected only by whatever action R1-R2 may have as a load, but they are of high value and can be ignored.

With the high output voltage, the negative feedback voltage is also high. High feedback voltage tends to buck or cancel the amplifier input voltage and thus reduce the output to a lower value than it would be without feedback.

Now we connect the load in place. The output voltage immediately goes down. But since there is less negative feedback, there is less cancellation at the input and the output voltage tends

to rise. This is readily explained.

What is happening is that the presence of negative feedback is preventing the output voltage from making the drastic changes it ordinarily would make with a change in load. If the internal resistance were lower, that, too, would reduce the output voltage changes with load changes. Therefore, the addition of negative feedback has the same effect as lowering the internal resistance—that is, the output impedance—of the amplifier!

Amplifier output impedance has an important effect on loudspeaker damping. A loudspeaker is a type of motor. As such, an applied voltage makes it move. But in addition, any movement of the loudspeaker cone creates a voltage at the speaker terminals. (All motors are also generators.) If the speaker terminals are short-circuited, the voltage created by the movement results in high current through the voice coil, which creates magnetic lines of force that interact with the field magnet in the correct direction to arrest the motion, thus braking the motor.

When a sudden drumbeat (or the leading edge of a square wave) comes along, the speaker cone is suddenly pushed. If there is a high impedance across the voice-coil terminals there is nothing to stop the cone's rather resilient mounting from causing it to vibrate like a gong until its mechanically stored energy is dissipated, giving a very, very muddy reproduction of the drum beat. But if the amplifier output

impedance is very low, the voice coil is nearly shorted and the vibrations are quickly damped out. This is the importance of negative feedback for speaker damping. The higher the feedback, the better the damping.

Some numbers

Negative feedback in an amplifier is usually cited in decibels—for instance, such and such an amplifier has "20-db negative feedback." This simply means that the gain of the amplifier with feedback is 20 db less than if the feedback loop or loops were removed. The figure depends on two factors—the gain of the amplifier without feedback and the percentage of feedback β .

The formula is very simple:

$$\frac{A}{A'} = 1 + \beta A$$

A/A' is always greater than 1, since the feedback always reduces the gain of the amplifier to an effective value A' less than that without feedback A . The formula itself shows very clearly that the reduction in gain (which is a direct indication of the effective negative feedback) is directly proportional both to β and to A . As an example, the hypothetical amplifier we dealt with in Figs. 1 through 4 had a gain of 2 and β of 25% or 0.25. The ratio of A/A' was then $1 + (0.25 \times 2)$ or 1.5, which corresponds to a loss of about 3.5 db. This low figure for a β of as much as 25% might be surprising, until we look at the A term in the equation and see that 2 is very low gain—only 6 db.

To cite a more usual situation: A 25-watt amplifier requires approximately 14 volts into an 8-ohm speaker, and may require an input of 1.4 volts for full 25-watt output. The gain with feedback is then 10 times. If 20 db of feedback is desired, then the amplifier gain without feedback must be 100, which is 20 db more than the with-feedback value of 10. Rearranging the formula above to find β ,

$$\beta = \frac{(A/A') - 1}{A}$$

Substituting the values gives us a value of .09 or 9% for β . This allows us to design the correct network to determine the amount of feedback.

Feedback methods

One of the most popular methods of connecting a feedback loop is to use an unbypassed cathode. This is done, for example, in the Bogen HO10 amplifier shown in the photograph, as can be seen from the schematic of Fig. 6. Feedback loop A is taken directly from the output transformer secondary to the cathode of the input stage through an attenuating and phase-correcting network consisting of a 100,000-ohm resistor and a 15- μ f capacitor. Phase correction is necessary at the extremes of the frequency range because negative feedback works as advertised only when the signal fed back is exactly 180 degrees out of phase with the input.

(Continued on facing page)

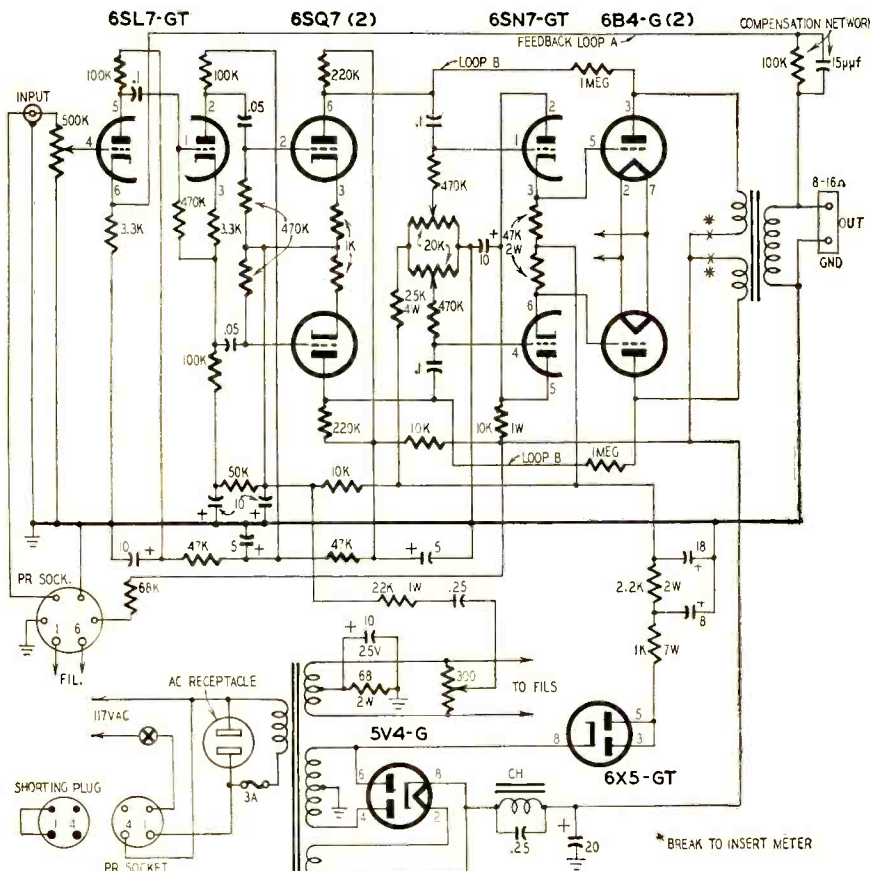
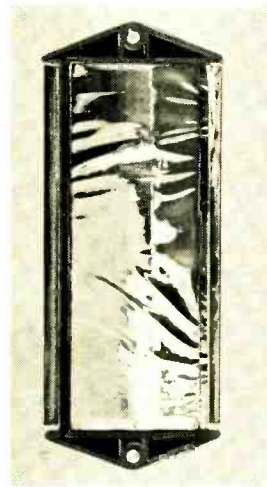
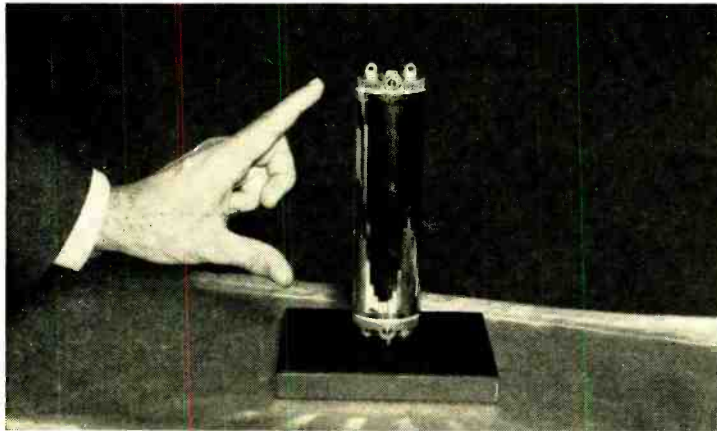

Fig. 6—The Bogen HO10 amplifier uses more than one type of negative feedback.

New Electrostatic Speakers



One of the eldest sound reproducing units rides again

Far left—The Philco speaker, nearer, the Columbia Kilosphere. Below—How the speaker is hooked up in a Philco receiver.

THE electrostatic speaker is the simplest of all sound transducers. It consists merely of two sheets of metal foil (one may be sheet metal) with a dielectric between them. A d.c. voltage across them maintains a steady attraction. Audio-frequency voltages add to or subtract from the polarizing voltage, causing the sheets to move together or apart according to the modulation.

Though known from the pre-radio days of the magician's "talking newspaper," the principle has long avoided "reduction to practice." True, several sets with electrostatic speakers were marketed in the late '20's, both here and in Europe. A photograph of one of the early German types appeared in "High-Fidelity Loudspeakers" (Part I) by Hartley, *RADIO-ELECTRONICS*, March, 1954. The American speakers were rectangular, with several square feet of surface.

Because of the high polarizing voltage (450 to over 2,000) and the perishable dielectric material, they were not satisfactory. Speakers that needed service were replaced by more tractable types, and the electrostatic speaker disappeared.

But the sound engineer has never been satisfied with any present type of speaker (see "Wanted—Inertialess Speakers," *RADIO-ELECTRONICS*, October 1953, as well as some of Mr. Hartley's remarks in the March, 1954, article),

(Continued from facing page)

This is true only at midfrequencies. At the extremes, tube capacitances, transformer reactances, and stray wiring reactances have a phase-shifting effect.

The worst possibility is that phase may change 180 degrees so that the feedback becomes positive and causes oscillation. Actually—depending on the number of reactive components in the amplifier and the wiring care—phase begins to shift fairly early in both

and the electrostatic unit still showed promise. High voltage in home receivers is no longer a problem, and new plastics offer better dielectrics.

Within the last two years a new electrostatic speaker has been announced in Germany (*RADIO-ELECTRONICS*, April, 1953, page 66), and now Philco and Columbia have announced simultaneously that they will have electrostatic tweeter units on their fall models.

Their advantages lie in their undecreased efficiency with rising frequency, the lack of "breakup" due to the speaker's being driven uniformly over the whole surface instead of from the center, and the fact that they can be so shaped as to radiate over a wide angle.

frequency extremes and if the β and amplifier gain are great enough oscillation will take place, even though phase shift is less than 180 degrees. It is possible to have 20 to 30 db of feedback with bandwidth out to several times the topmost audible frequency without compensation of any kind; but this requires direct coupling and the very highest quality output transformer, since distributed capacitance and leakage inductance in the trans-

(Both cone and horn tweeters tend to be sharply directional.) The electrostatic speakers should be cheaper than either cone or horn.

Technical information was released first on the Philco unit. It consists of 16 slim rectangular units "disposed as facets on a half-cylinder," thus causing it to disperse sound over a wide angle. The half-cylinder backplate is made of perforated aluminum, ribbed to create the 16 faces. The movable electrode is a plastic layer .0005 inch thick, with a thin metal film deposited on one side. A polarizing voltage of about 280 attracts the film toward the backplate, and the audio-frequency voltage, applied as shown in the schematic, causes it to move back and forth. **END**

former also count. It is cheaper (and as effective) to compensate for phase shift by using a simple network such as Fig. 6 shows.

Another usual trick is to use as many as three different feedback loops instead of concentrating all the feedback into one. This is done in the Bogen, the second loop being the one marked B between the output-stage plates and the driver grids. **END**

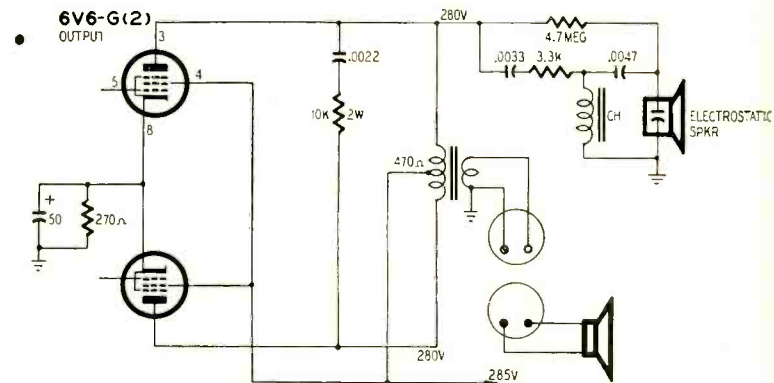

HIGH-FIDELITY LOUDSPEAKERS

By H. A. HARTLEY*

*Part V—The room
and its acoustics,
testing speakers,
response curves
and the
human factor*

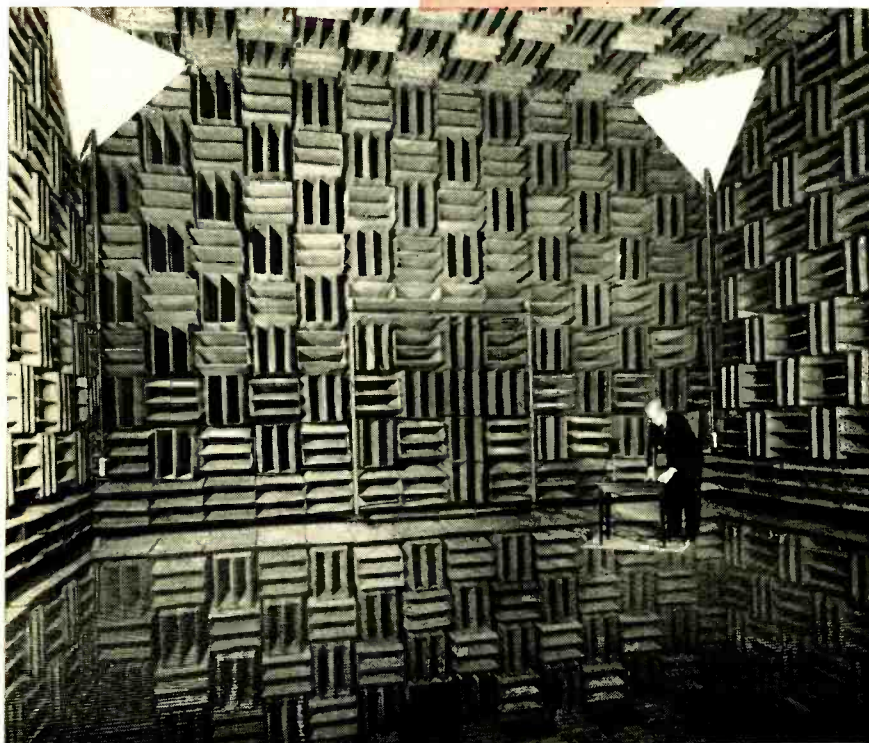

Fig. 1 — Anechoic test room used at Bell Laboratories.

WE can select a perfectly satisfactory speaker, enclose it in a properly designed housing, and consider the whole as something that will give sound reproduction closely approaching the original. This will happen only if the speaker assembly is used out of doors. Placed in an ordinary room, other factors make themselves audible. To demonstrate this, feed the amplifier with several frequencies, say 50, 200, 500, 1,000, 2,000, 5,000 and 10,000 cycles. Walk about the room, first with one ear toward the speaker and then facing the speaker. What are called standing waves, where the sound may almost disappear, occur in various places. These are brought about by room reflections and absorptions. Even in the open air there is no uniform distribution of sound, because no speaker has a perfect polar distribution at all frequencies; the usual fault is concentration of the high frequencies in a rather narrow beam. Generally speaking, the audio enthusiast is faced with the problem of locating a speaker

of comparatively unknown performance in a room of unknown acoustical behavior, and the best results can be found only by trial and error. Some generalizations can be made to help solve this difficult problem.

Usually the selected room exists; it cannot be altered in shape and size; the windows cannot be moved. Even the furniture and furnishings are somewhat fixed, for the room has to be lived in as well as act as a music room. There is something of a craze for custom audio-radio-TV combinations that take up part or all of one wall of a room. Esthetically, this may appeal to some people; to others it may seem like converting a home into something resembling a laboratory or a superequipped kitchen. Whatever may be thought of its appearance, such an installation is almost invariably bad acoustically. There are good reasons for this.

If the speaker is a good one, it will almost certainly require a housing that cannot be placed flat against a wall. Good enclosures must be placed a few inches from the wall with free space all around or in the corner of a room

so that adjacent walls form part of the folded horn. Good clean bass cannot be obtained from boxed-in speakers.

A good speaker can reproduce frequencies as low as 20 cycles. Reproduction of any frequency below about 100 cycles is accompanied by substantial vibration of the housing. If the housing is built into a large cabinet that also houses the record player, acoustic feedback is inevitable. This applies to any phonograph cabinet containing both record player and speaker, even if the player is mounted on springs and the speaker housing is rubber-suspended. If any combined installation does not give acoustic feedback, it can be assumed that the bass is absolutely cut off at about 50 cycles or higher—generally higher. Those unacquainted with the behavior of the human ear may not believe this, but the ear can give an impression of a low fundamental by working back from the second, third and higher harmonics. Direct comparison between this pseudo-bass and real bass that includes the fundamental at its proper amplitude shows at once what is missed by a bass cutoff in the reproducing equipment.

*H. A. Hartley Co., Inc.

**It's New! 3 Years in Development
-NOW READY FOR YOU!**

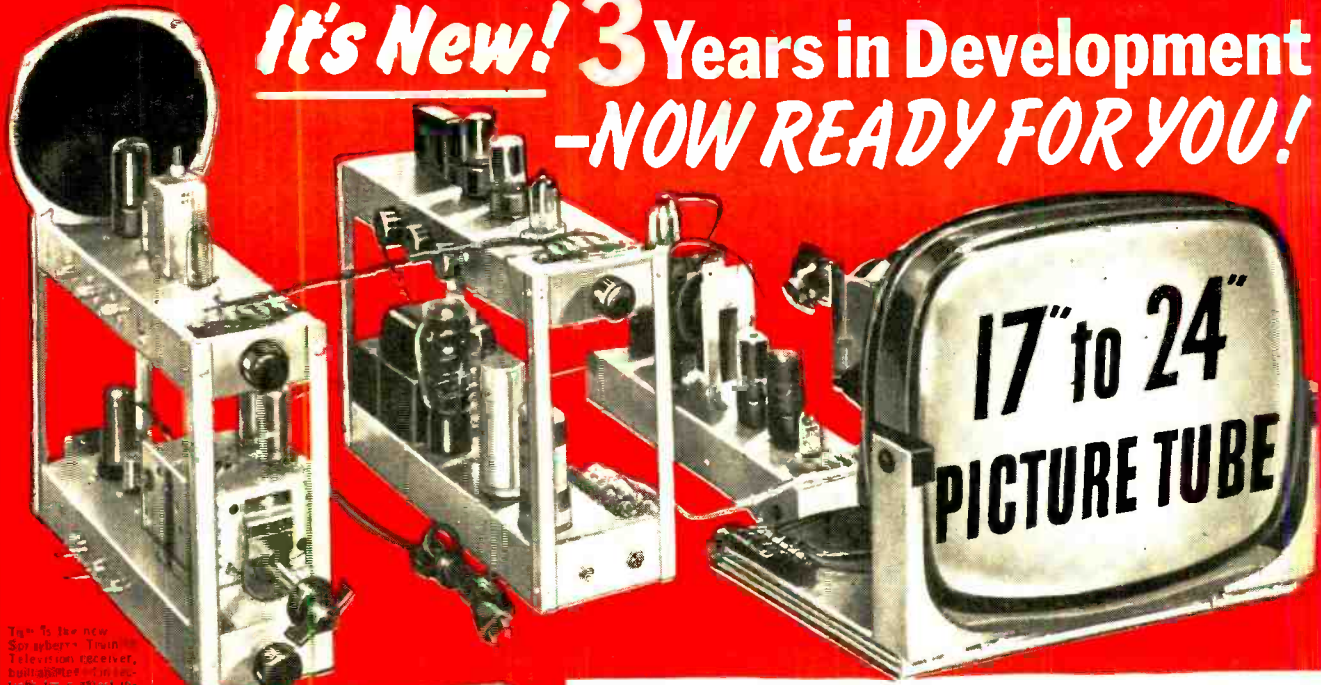

Top to bottom: Sprayberry Training Television receiver, built-in receiver, built-in receiver with a 17" to 24" picture tube.

**17" to 24"
PICTURE TUBE**

New Equipment! New Lessons! Enlarged Course!
SPRAYBERRY PRACTICAL TRAINING IN
RADIO-TELEVISION
3 NO OBLIGATION TRAINING PLANS



These photos show only a small part of the training equipment sent my students.

You build the new Sprayberry Tester. It tests you Ohm, Millivolt, Resistance plus output meter and condenser and resistor substitution circuit.



Frank L. Sprayberry
President, Sprayberry
Academy of Radio

**You have NO MONTHLY PAYMENT CONTRACT to sign
... pay for this outstanding training as you learn!**

The complete facts are so big and so important to any man seeking training in Radio-Television that I urge you to mail the coupon below at once for my big all-new 56 page FREE CATALOG and FREE Sample Lesson. Get the full story of this remarkable new and up-to-the-second Training Plan. You'll read about my 3 NO OBLIGATION PLANS or "packaged unit" instruction for both beginners and the experienced man. You'll learn how I can now prepare you in as little as 13 MONTHS to take your place in this fast moving big money industry as a Trained Radio-Television Technician. You'll see that you take no risk in enrolling for my Training because you DO NOT SIGN A BINDING TIME PAYMENT CONTRACT. I have been training successful Radio-TV technicians for 22 years... I can prepare you, too, to get into your own profitable Service Shop or a good paying job, even if you have no knowledge of Radio-Television. Mail the coupon... I rush full information FREE and without obligation. (No salesman will call.)

NEWEST DEVELOPMENTS

Your training covers U H F, Color Television, F M, Oscilloscope Servicing, High Fidelity Sound and Transistors.

PRACTICE AND TRAIN AT HOME WITH 25 NEW KITS OF EQUIPMENT

You get valuable practical experience in construction, testing and shop practice. You build a powerful 2 band superheterodyne radio, the all-new 18 range Sprayberry multimeter, the new Sprayberry Training Television receiver, signal generator, signal tracer and many other projects. All equipment is yours to use and keep... and you have practically everything needed to set up a Radio-Television Service Shop.

All your training is IN YOUR HOME in spare hours. Keep on with your present job and income while learning. I help you earn extra spare time money while you learn. If you expect to be in the armed forces later, there is no better preparation than practical Sprayberry Radio-Television training. Rush coupon below for all the facts—FREE!

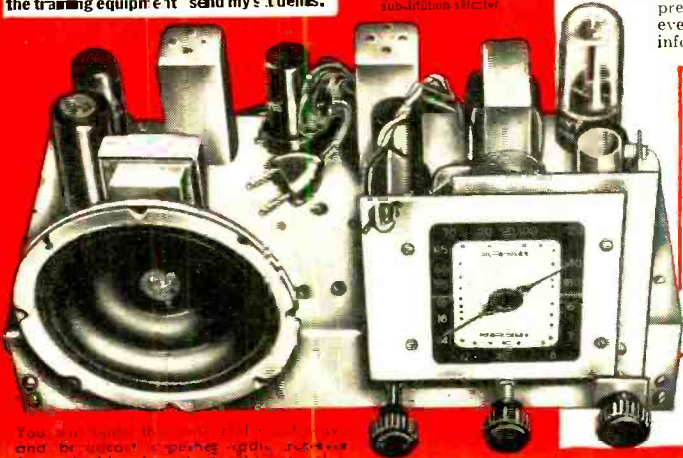

You can make the most of your spare time and be successful in your radio service for valuable shop instruction practice.

SPRAYBERRY ACADEMY OF RADIO
111 NORTH CANAL STREET, DEPT. 20-P, CHICAGO 6, ILLINOIS

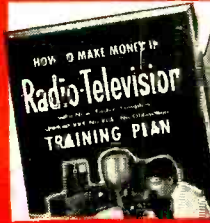

FREE CATALOG AND SAMPLE LESSON

Rush coupon for my catalog "How to Make Money in Radio-Television". PLUS an actual sample Sprayberry Lesson without obligation—ALL FREE. Mail coupon NOW!

SPRAYBERRY ACADEMY OF RADIO MAIL THIS COUPON FOR FREE
Dept. 20-P, 111 N. Canal St., Chicago 6, Ill. FACTS AND SAMPLE LESSON

Please rush all information on your ALL-NEW Radio-Television Training Plan. I understand this does not obligate me and that no salesman will call upon me. Include New Catalog and Sample Lesson FREE.

Name _____ Age _____
Address _____
City _____ Zone _____ State _____

AUDIO—HIGH FIDELITY

For best results it is essential to separate the player from the speaker. The speaker should be placed where it will sound best. The type of speaker used must depend on the size of the room. If the room is small, a direct-radiator single speaker is essential, for multiple-channel speakers give excessive phase displacement of the treble as compared with the bass unless the listener is some distance away. With horn speakers the distance must be even greater. A safe rule is that a horn-loaded speaker should not be used in a room smaller than 30 feet long, especially if it is a combination of woofer and tweeter.

Reflection over the frequency spectrum varies. High frequencies being most easily absorbed, an overfurnished room will give an impression of lack of top; a sparsely furnished room will have undue low-frequency reverberation. It is unfortunate that through the whole process of sound reproduction, what is good for the highs is bad for the lows. At the same time, if some attempt at a happy medium is reached, the high-frequency focusing of the speaker must be allowed for. It is undesirable to sit in the beam of the speaker. Since only one person can do so at any given time, it is better to arrange the seating so that no one does. The wall opposite the high-frequency beam should have some light damping to avoid reflection. A thin curtain is sufficient. Alternatively a good deal of success in spaciousness of reproduction can be achieved by directing the speaker at an adjacent corner, if already placed in a corner, without damping, so that the highs are scattered by the opposite wall. Then no one sits in the beam, and distributed highs reach everyone.

Unless the building is a solid and substantial one, bass will be lost through floor reverberation. Mount the speaker housing on sponge rubber—the low-frequency energy from the speaker must be used to move air, not the building. If such bass loss is supposedly made good by boost in the amplifier, amplitude distortion of the fundamental and harmonics will occur and give an unnatural sound.

Generally speaking, the best place for a speaker cabinet is in a corner of the room, for the walls help to reflect the sound forward. If the enclosure is of the open-back type, this can be very valuable in directing the lowest frequencies which have escaped from the back toward the listener. The walls in the corner of the room should not be damped by curtains or other absorbent material; they should act as reflectors. Testing of all these aspects of speaker placement is best done by using a frequency test record with a wobble tone, which helps break up standing waves; a steady tone record is almost useless unless it is desired to find out where and when the standing waves occur.

The difficulty at all times is to obtain uniform distribution of sound, and the

idea I put forward in an earlier article—clean bass at adequate volume can be achieved by using several small speakers instead of one large one—is of value in getting better distribution. In Britain some speakers are mounted in such a way that the sound is projected to the ceiling, either vertically or at an angle, the ceiling being used as a large reflector. If the speaker, as normally used, has a high-frequency beam, this method gives good dispersion of the highs. If the listening room is small, so that one cannot sit at a fair distance from the speaker, ceiling reflection does help the general effect noticeably.

Ornaments, pictures hanging on the wall, and particularly a piano, in which every string is a resonator, tend to set up local centers of interference, especially if the speaker is run at good volume. Of course, removal of these may set up an interference center with the feminine half of the home administration, but the point is mentioned since it is frequently overlooked. It seems absurd that a vast amount of work directed toward removing resonances from the speaker should be cancelled out by introducing resonances in the listening room.

If domestic law and order insist that the speaker must be put "there" and no where else, the sound output can be deflected by mounting a set of narrow baffle plates, like a miniature venetian blind set on edge, across the speaker opening. Naturally, care must be taken

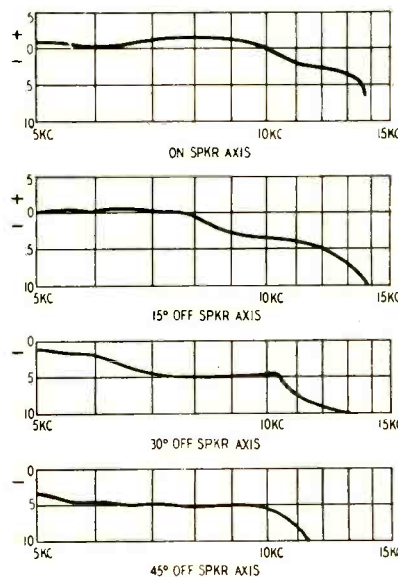

Fig. 2—Typical loudspeaker response curves taken on and off speaker axis.

that the individual slats do not rattle.

Finally, if two speakers are used in such positions that one is appreciably farther away than the other from the listener, so that the time of transit of the sound waves is different, a startling imitation of stereophonic reproduction can be obtained. The speaker beams should not intersect within the room. A good deal of experimenting will be

required to get the best possible results.

Testing high-fidelity loudspeakers

Proper testing of a speaker can be carried out only in a fully equipped acoustical laboratory. The speaker must be placed in a testing compartment that is completely inert and has no echo, or must be measured in the open air where there is no interfering noise. A suitable location for open-air operation is hard to find, and this accounts for the construction of expensive anechoic test rooms (Fig. 1). Serious work cannot be carried out without such an "auditorium."

Given such a test room and all the accompanying measuring gear, certain facts can be established. A frequency response curve can be taken with sine-wave input, on and off the axis (Fig. 2). From a series of such curves polar diagrams (Fig. 3) can be drawn showing the forward radiation at various frequencies. This information has no absolute value, for it refers to a specific speaker in specific surroundings. Other speakers can be measured under exactly similar conditions, and their curves can be compared with the first speaker; this will give relative performance, and that is all.

Such curves are called static curves; they show a speaker's performance under steady conditions. Most speakers show different responses with different input currents. Strictly speaking, there should be a family of curves for applied voltages of, say, 1 to 5, and this family of curves should be integrated to give average performance.

In reproducing music, speakers are not working in a steady state. The information given by the steady-state curves must be supplemented by photographs of oscillograms taken when the signal generator supplying the test input to the speaker is modulated by a sweep generator. These two sets of data will then give a fairly comprehensive picture of the performance of one speaker with respect to another, provided both speakers have been measured in identical housings. If the performance of speakers in their own properly designed housings is wanted, then these housings must be used in the test. My reason for mentioning this apparently obvious point is that even if speaker manufacturers agreed among themselves to submit their products to an independent authority, so that standardized data would be available to the public, the information would not be very useful if speakers were sold as units without cabinets—and most speakers are sold to be housed by the purchaser in whatever cabinet he wishes to use.

The foregoing data gives little information about transient response. The most useful work in this direction has been carried out by Shorter of the British Broadcasting Corporation. A speaker having a light diaphragm-voice-coil assembly and a smooth frequency response gives a rapid build-up

NEW 1955

Heathkit

Engineering Features

New PRINTED CIRCUITS

One of the many tremendous improvements in the new 1955 Heathkits is the use of an etched metal process printed circuit board. Printed process printed circuit boards whenever they will affect construction simplification, performance stabilization, and lend themselves to instrument design. Now for the first time a kit instrument company offers the advantages of modern printed circuit instrument construction technique. For the first time consideration has been given toward reducing time. Also this is the first time that printed circuit boards have been hand soldered on a volume basis. Offered only by Heathkit, the pioneer and leader in kit instrument design.

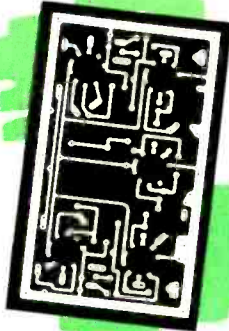

New PEAK-TO-PEAK VTVM CIRCUIT

New 6AL5 full wave rectifier in AC input circuit permits full scale peak-to-peak measurements. Seven ranges — upper limit 4000 volts peak-to-peak. Just the thing you TV servicemen have needed in making TV circuit voltage checks. Precision resistor voltage divider limits AC RMS level to 150 volts. Prevents overloading the rectifier — extends upper limit AC RMS range to 1500 volts — further protects meter and circuitry against AC flash-over or arcing. Another definite example of continuing Heathkit design leadership in the kit instrument field.

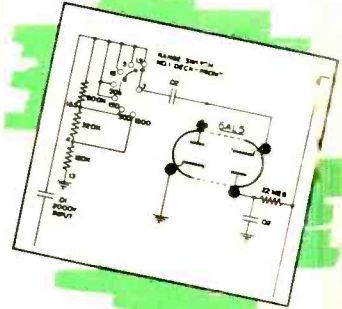

New HIGH READABILITY PANELS

New 1955 Heathkits feature complete panel redesign. Sharp white lettering applied to the beautiful charcoal gray panels, provide a new high in readability. Lettering is easy-to-read open style and panel calibrations are vividly clear against the pleasing soft gray background. New knobs of exclusive Heathkit design.



New 3" UTILITY SCOPE

The new 3" Scope is a "natural" for the well rounded line of Heathkit instruments. Small in size, 11 3/4" deep, 6 1/2" wide, 9 1/2" high, yet big in performance. Just think of the value, an Oscilloscope for \$26.50. Brilliant intensity, sharp focusing, wide positioning range. An ideal portable Scope for the TV serviceman — a second shop scope — modulation men for you hams (deflection plate terminals in rear of cabinet). Performance to spare for all general scope applications. See specifications on following page.

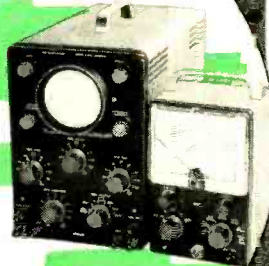

New STYLING New COLOR

New styling and coloring is responsible for tremendous improvement in Heathkit appearance. The new instrument panel color combination is high definition white lettering in a soft charcoal gray panel. Cabinet color is a lighter leather gray. The satin gold baked enamel cabinet for the WA-P2 Pre-amplifier is further indicative of the modern pacemaking trend in Heathkit styling.



New SCOPE SWEEP CIRCUIT 10 CYCLES — 500 KC

New 1955 Heathkit Model 0-10 Scope features a new wide frequency range sweep generator covering 10 cycles to 500,000 cycles. This coverage is available in five virtually decade wide sweep ranges and is five times greater than the sweep frequency range usually available. Excellent retrace time characteristics, actually less than 20% at 500 K.C. Use of the free running Heath circuit provides a larger margin of stability and a new high in Heathkit Scope performance.

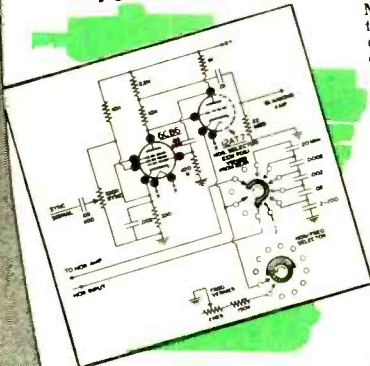

Continuing PROGRESS FUTURE LINE EXPANSION

The outstanding improvements featured in the 1955 Heathkit line are representative of the progress characteristic of the Heath Company operation. Long range planning will provide a continuing accession of new kit releases to further expand the Heathkit line which already represents the world's greatest selection of electronic kits. The innovations in the 1955 line, are representative of additional new models scheduled for release for the coming years.



SEE THE INSTRUMENTS
ON THE FOLLOWING PAGES

HEATH COMPANY • Benton Harbor 20, Mich.

Heathkit ELECTRONIC SWITCH KIT

The basic function of the Heathkit Electronic Switch Kit is to permit simultaneous oscilloscope observation of two separate traces which can be either separated or superimposed for individual study. This is accomplished through the use of two individually controlled inputs working through amplifier, multivibrator, and blocking stages. The output of the Electronic Switch is connected directly to the vertical input of the Oscilloscope. A typical example of usefulness would be simultaneous observation of a signal or waveform as it appears at both the input and output stages of an amplifier.

APPLICATIONS

An Electronic Switch has many applications to increase the over-all operating versatility of your oscilloscope. It can be used to check amplifier distortion—audio crossover networks—phase inverter circuits—to measure phase shift—special waveform study, etc. The instrument can also be conveniently used as a square wave generator over the range of switching frequencies, often providing the necessary wave form response information without incurring the expense of an additional instrument. Ownership of this instrument will reveal many entirely new fields of oscilloscope application and will quickly justify the modest cost of the Electronic Switch Kit.

Tube complement: 6AV6, 6AV7, 6AV8, 6AV9, 6AV10, 6AV11, 6AV12, 6AV13, 6AV14, 6AV15, 6AV16, 6AV17, 6AV18, 6AV19, 6AV20, 6AV21, 6AV22, 6AV23, 6AV24, 6AV25, 6AV26, 6AV27, 6AV28, 6AV29, 6AV30, 6AV31, 6AV32, 6AV33, 6AV34, 6AV35, 6AV36, 6AV37, 6AV38, 6AV39, 6AV40, 6AV41, 6AV42, 6AV43, 6AV44, 6AV45, 6AV46, 6AV47, 6AV48, 6AV49, 6AV50, 6AV51, 6AV52, 6AV53, 6AV54, 6AV55, 6AV56, 6AV57, 6AV58, 6AV59, 6AV60, 6AV61, 6AV62, 6AV63, 6AV64, 6AV65, 6AV66, 6AV67, 6AV68, 6AV69, 6AV70, 6AV71, 6AV72, 6AV73, 6AV74, 6AV75, 6AV76, 6AV77, 6AV78, 6AV79, 6AV80, 6AV81, 6AV82, 6AV83, 6AV84, 6AV85, 6AV86, 6AV87, 6AV88, 6AV89, 6AV90, 6AV91, 6AV92, 6AV93, 6AV94, 6AV95, 6AV96, 6AV97, 6AV98, 6AV99, 6AV100.

Continuously variable switching rates in three ranges from less than 10 CPS to over 2000 CPS.

Individual input gain controls, position control, coarse frequency control, and fine frequency control.

Transformer operated for safety when used in conjunction with other equipment.



MODEL S-2

\$23⁵⁰

Shpg. Wt.
8 lbs.

Heathkit VOLTAGE CALIBRATOR KIT



MODEL VC-2

\$11⁵⁰

Shpg. Wt. 4 lbs.

Another useful oscilloscope accessory particularly in circuit development work and in TV and radio service work. The Voltage Calibrator provides a convenient method for making peak-to-peak voltage measurements with an oscilloscope, by establishing a relationship on a comparison basis between the amplitude of an unknown wave shape and a known output of the voltage calibrator. Peak-to-peak voltage values are read directly from a calibrated panel scale without recourse to involved calculations.

FEATURES:

To off-set line voltage supply irregularities, the instrument features a voltage regulator tube. A convenient "signal" position on the panel switch by-passes the calibrator completely and the signal is applied through the oscilloscope vertical input, thereby eliminating the necessity for constantly transferring test leads.

RANGES:

With the Heathkit Voltage Calibrator it is possible to measure all types of complex waveforms within a voltage range of .01 to 100 volts peak-to-peak. Build this instrument in a few hours and enjoy the added benefits offered only through combination use of test equipment.

Heathkit LOW CAPACITY PROBE KIT



No. 342

\$3⁵⁰

Shpg. Wt. 1 lb.

An oscilloscope accessory, the 342 Low Capacity Probe permits observation of complex TV waveforms without distortion. An adjustable trimmer provides proper matching to any conventional scope input circuit. Excellent for high frequency, high impedance, or broad bandwidth circuits. The attenuation ratio can be varied to meet individual requirements.

Heathkit SCOPE DEMODULATOR PROBE KIT



No. 337-C

\$3⁵⁰

Shpg. Wt. 1 lb.

Extend the usefulness of your oscilloscope by observing modulation envelopes of RF or IF carriers found in TV and radio receivers. The Heathkit Demodulator Probe will be helpful in alignment work, as a gain analyzer and a signal tracer. Easy construction with the new modern printed circuit board. Voltage limits are 30 volts RMS and 500 volts D.C.

AUDIO—HIGH FIDELITY

of a transient impulse, but the decay of the transient must also be considered. A lightly damped resonator (such as a speaker cone) when shock-excited by a suddenly applied impulse, will "ring" at its own resonant frequency, and this ring will continue in the absence of damping. Shorter measures the frequency response at time intervals of 0, 10, 20, 30, and 40 milliseconds after the applied voltage has ceased. Good transient-reproducing capabilities require attenuation of 35 db at 3,000 cycles, 50 db at 5,000 cycles within 10 milliseconds; a further attenuation of 10 db in the next 10 milliseconds and further appreciable attenuation within the next 20 milliseconds. Obviously, measurements of this sort are beyond the resources of the average technician.

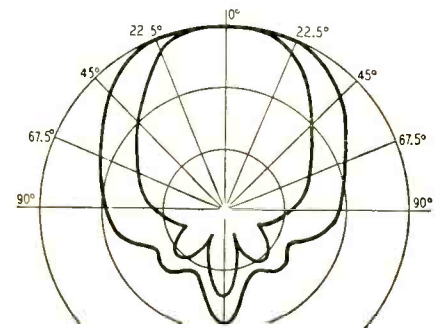

Fig. 3 — Polar diagram of Electro-Voice model 848 loudspeaker system.

However, one need not despair. A good deal of useful information can be obtained with comparatively simple tests. In the case of direct-radiator speakers, mount the unit to be tested on a simple reasonably rigid baffle. Rest the baffle on sponge rubber so that the energy of the speaker is not wasted at low frequencies by setting up vibration in surrounding objects. Use an amplifier of known freedom from distortion, and excite the amplifier with a sinusoidal output from an audio generator. Find the bass resonant frequency of the speaker and set the volume so that the speaker is just not overloading; thereafter keep the input to the speaker constant.

The output from the speaker should have the characterless sound of a pure sine wave; any harmonic present will give some quality to the sound, and the harmonic may come from the amplifier or the signal generator. Sweep slowly up the scale listening for any suggestion of rattles; if noticed, they should be hunted down. A probe consisting of a pencil to one end of which has been cemented a small piece of sponge rubber is useful for touching the various parts of the speaker. Listening to the speaker under ordinary surroundings will suggest that the response is full of dips and peaks; most of these will be due to room acoustics, but if the oscillator can produce a wobble tone, this will help to cancel out standing waves.

Nodes in the cone can produce

HEATH company

BENTON HARBOR 20,
MICHIGAN

NEW Heathkit 5" PUSH-PULL OSCILLOSCOPE KIT PRINTED CIRCUIT

The new 1955 Heathkit Model O-10 is the first truly color television kit oscilloscope with necessary high sensitivity and bandwidth. Outstanding instrument appearance is the result of new modern styling and color harmony. The first kit constructed oscilloscope to offer a labor-saving printed circuit board. New sweep generator with frequency range five times greater than previous models. Additional major improvements are a new high voltage power supply, improved vertical and horizontal electronic positioning control action, extreme horizontal amplifier sensitivity for trace magnification over three times CRT face width.

NEW SWEEP GENERATOR: The first sweep generator outside of expensive Laboratory units to go above 100 KC. Yet this new Heathkit has five times the frequency range with stable, locked-in traces. Complete range 10 cycles to 500,000 cycles. The generator has such excellent synchronization characteristics, that the results closely approximate a triggered sweep and under most conditions, the trace is locked to a multiple of sync frequency throughout the entire control range. Sweep multi-vibrator is direct coupled pentode-triode and frequency determining capacitors are not part of multi-vibrator circuit.

Simplified, standardized construction technique of vertical and horizontal amplifier construction made possible through the use of a single printed circuit board.

SENSITIVITY AND BANDWIDTH: Operating characteristics of the newly designed vertical amplifier provide a high degree of sensitivity (25 millivolts per inch) and excellent bandwidth characteristics 5 cycles to 5 MC (down only 5 db). Only the new Heathkit Oscilloscope has the necessary sensitivity for full 5 megacycle bandwidth for color servicing. Uniformly high level operation with a high degree of stability is assured through the use of new printed circuit board construction. Printed circuits reduce the assembly time, error possibility, and provide rigid mounting for all components.

New horizontal amplifier provides trace width three times the diameter of the CR tube. This new amplifier together with DC positioning, allows greater magnification of trace for observation of small transients and step portions of TV sync pulses.

OTHER OUTSTANDING FEATURES: Retrace amplifier—Z axis modulation—peak-to-peak voltage calibrating source with calibrated grid—all plastic molded condensers for long trouble-free life and drift elimination—voltage regulated power supply—new wiring harness for neat professional appearance—new cabinet styling and color harmony. Combinations of design and performance features available only in the new Heathkit O-10 Oscilloscope.

First color television service Oscilloscope with necessary high sensitivity and full 5 megacycle bandwidth.

New printed circuit construction, all components mounted on high insulation surface resulting in uniformly low circuit capacities.

New type wide frequency range Heath sweep generator, 10 cycles to 500,000 cycles.

New SUP1 CR tube



New cabinet styling and color harmony—charcoal gray panel with high readability white lettering.

New electronic positioning controls for instantaneous, definite positioning without bounce or overshoot.

MODEL O-10

\$69⁵⁰

Shpg. Wt. 27 lbs.

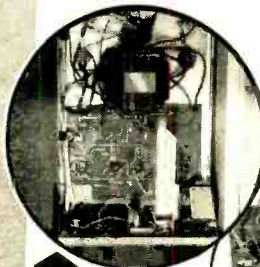

Clean, open, under chassis construction and wiring. Possible only through use of pre-cabled wiring harness, and simplified printed circuit boards.

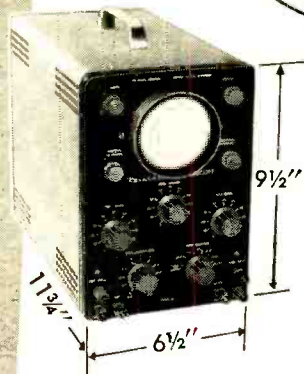
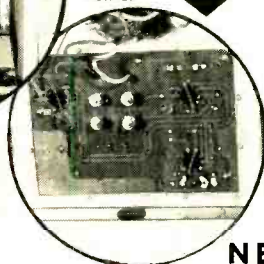

NEW Heathkit 3" PRINTED CIRCUIT OSCILLOSCOPE KIT

MODEL O-1

\$29⁵⁰

Shpg. Wt. 15 lbs.

New easy-to-build printed circuit board with high insulation factor.

New Heathkit instrument styling—charcoal gray panel with high readability white lettering.

New Heath twin triode sweep generator 15-100,000 cycle sweep.

New compact utility Scope—light weight—portable for service work.

Deflection plate terminals—ideal for ham transmitter modulation monitoring.

Here is the newest addition to the line of Heathkit Oscilloscopes. Just the instrument you servicemen, ham, students, and experimenters have been asking for. A general purpose low priced utility scope to be used in everyday work. Through the use of a 3" 3GPI CRT it has been possible to reduce the cabinet size and weight so that the instrument is a compact portable unit especially useful for TV servicemen to carry on home service calls and as an extra shop utility scope. At this low price every ham can afford an oscilloscope for transmitter modulation monitoring. Convenient slide switch controlled terminals at rear of scope cabinet.

PRINTED CIRCUIT: This new Heathkit uses a prefabricated printed circuit board to standardize amplifier and sweep generator assembly. Cuts building time in half, eliminates major portion of wiring, and insures exact duplication of engineering pilot model. Condensers, resistors, and tube sockets are mounted directly on the board and soldered in place.

DESIGN FEATURES: Cathode follower input circuits in both vertical and horizontal amplifier—electronic positioning control for wide range of vertical or horizontal spot deflection—Heath twin triode sweep generator—provisions for external and internal sync—external and internal sweep—60 cycle line sweep—Chicago power transformer—4 section electrolytic filter condenser—plastic molded bypass and coupling condensers. Tube lineup 4—12AU7 horizontal and vertical amplifiers, 12AX7 sweep generator, 6X4 low voltage rectifier, 1V2 high voltage rectifier, 3GPI CRT. Cabinet size 11 3/4" deep x 6 1/4" wide x 9 1/2" high. A terrific instrument value at \$29.50.

NEW Heathkit 5" PRINTED CIRCUIT OSCILLOSCOPE KIT

MODEL OM-1

\$39⁵⁰

Shpg. Wt. 24 lbs.

Printed circuit board construction for accurate trouble-free assembly.

Twin triode Heath sweep generator 15-100,000 cycle range.

By popular request we are again offering a 5" full sized general purpose Oscilloscope using a 5BPI CRT. All of the necessary design features for servicemen, students, experimenters, ham, etc. This fine oscilloscope value features printed circuit board construction for easy assembly and reduced wiring time. Also features the new Heathkit styling and color harmony with the charcoal gray panel and white lettering for high readability.

SWEEP GENERATOR: Sweep generator range using Heath twin triode circuit 15-100,000 cycles in four positions. Provisions for external as well as internal sweep and external or internal sync in addition to 60 cycle line sweep. Easy positive synchronization.

Heavy duty power supply using TV type 1V2 high voltage rectifier assures adequate accelerating potential for good trace definition. Deflection plate direct terminal connections available on rear of cabinet. Useful in transmitter modulation checking.

Good performance, simplified operation, and easy assembly are all characteristics of this new model Heathkit Oscilloscope.



HEATH company
BENTON HARBOR 20,
MICHIGAN

Heathkit MULTIMETER KIT

The new Heathkit Multimeter is a "must" to complete the instrument lineup of any well equipped service shop. Here is an instrument packed with every desirable service feature, many of which are not found in other Multimeters. All of the measurement ranges you need or want. High sensitivity 20,000 ohms per volt DC; 5,000 ohms per volt AC.

★ ADVANTAGES

Complete portability through freedom from AC line power operation—provides service ranges of direct current measurements from 150 microamps up to 15 amperes—can be safely operated in RF fields without impairing accuracy of measurement.

★ RANGES

Full scale AC and DC voltage ranges are 0-1.5, 5, 50, 150, 500, 1500 and 5,000 volts. Direct current ranges are 150 microamps, 15, 150 and 500 milliamperes and 15 amperes. Resistances are measured from .2 ohms to 20 megohms in 3 ranges and db range from -10 to +65 db.

★ CONSTRUCTION

The Heathkit MM-1 features a unique resistor ring switch mounting assembly procedure. With this method of assembly the precision resistors are wired to the rings and range switch before actual mounting of the switch to the instrument panel. This procedure affords the advantage of simpler construction yet complete accessibility of precision resistors in event replacement is ever required. Ohmmeter batteries were selected for convenience of replacement and only standard commercially available types are used. Batteries consist of 1 type C flashlight cell and 4 Penlite cells. All batteries and necessary test leads are furnished with the kit.

20,000 ohms per volt sensitivity DC; 5,000 ohms per volt AC.

Polarity reversal switch eliminates transferring of test leads.



All 1% precision multiplier resistors—sensitive 50 Simpson meter.

Total of 35 meter ranges on two color scale.

New modern cabinet styling—attractive appearance.

MODEL MM-1

\$26.50

Shpg. Wt. 6 lbs.

Heathkit HANDITESTER KIT



MODEL M-1

\$14.50

Shpg. Wt. 3 lbs.

The Heathkit Model M-1 Handitester readily fulfills major requirements for

a compact, portable volt-ohm milliammeter. The small size of the smooth gleaming molded bakelite case permits the instrument to be tucked into your coat pocket, toolbox or glove compartment of your car. Always the "Handitester" for those simple repair jobs.

RANGES:

Despite its compact size, the Handitester is packed with every desirable feature required in an instrument of this type. AC or DC voltage ranges, full scale, 10, 30, 300, 1,000 and 5,000 volts. 2 convenient ohmmeter ranges 0-3,000 ohms and 0-300,000 ohms. 2 DC milliammeter ranges 0-10 milliamperes and 0-100 milliamperes.

CONSTRUCTION

The instrument uses a 400 microampere meter movement which is shunted with resistors to provide a uniform 1 milliamper load in both AC and DC ranges. This design allows the use of but 1 set of 1% precision divider resistors on both AC and DC and provides a simplicity of switching. A small hearing aid type ohms adjust control provides the necessary zero adjust function on the ohmmeter range. The AC rectifier circuit uses a high quality Bradley rectifier and a dual half wave hookup. Necessary test leads and battery are included in the price of this popular kit.

Heathkit RESISTANCE SUBSTITUTION BOX KIT

MODEL RS-1

\$5.50



Shpg. Wt. 2 lbs.

36 standard RTMA 1 watt resistor values between 15 ohms and 10 megohms with an accuracy of 10% are at your fingertips in the Model RS-1 Resistance Substitution Box kit. This sturdy and attractive accessory will easily prove its worth many times over as a time saving device. Order several today.

Heathkit CONDENSER SUBSTITUTION BOX KIT

MODEL CS-1



\$5.50

Shpg. Wt. 2 lbs.

18 standard RTMA values are available from .0001 mfd to .22 mfd. An 18 position switch set in the panel of an attractive bakelite case allows quick changes without touching the test leads. Invest a few minutes of your time now and save hours of work later on.

HEATH company

BENTON HARBOR 20,
MICHIGAN

AUDIO—HIGH FIDELITY

rattles although the voice coil may not be rubbing and no part of the speaker is loose. The nodes can be seen by examining the speaker under a strobe light, but stroboscopes cannot be geared up to high audio frequencies (which is not very important since nodes are most troublesome at low and lower-middle frequencies).

A check on the response curve can be made by taking an impedance curve, which will not display minor distortions, but will show baffle resonance, cabinet resonances, and the fundamental bass resonance of the speaker as well-marked peaks. The impedance of a speaker rises with frequency, so take no notice of the general gradient of the curve, but only of the peaks. Usually, published response curves of speakers (Fig. 4) are taken with a

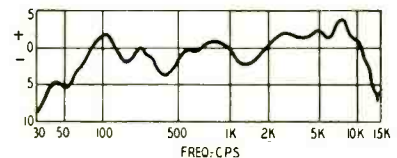

Fig. 4—Frequency response curve of University model 6200 loudspeaker

1-volt input. To find defects in the speaker use the largest input possible, the limit being the power-handling capacity at bass resonant frequency.

Intermodulation distortion can be checked very easily. Apply a low frequency to the speaker. If the bass resonance is below 60 cycles, the power-line supply can be applied to the voice coil through an ordinary output transformer; if above, then the low-frequency test voltage will have to be supplied by a second audio oscillator. Apply the low-frequency voltage to the speaker so that the cone is fully deflected. Now add, from the original oscillator, a signal of some frequency between about 3,000 and 5,000 cycles, a frequency to which the ear is usually sensitive. If there is a low-frequency wobble on the high-frequency note, the speaker suffers from intermodulation distortion. This statement will be challenged by the "Doppler school," but I maintain, and have proved it before technical audiences, that if a magnet system is so designed that the voice coil does not enter a weaker magnetic field at any point of its excursion, the wobble will not be heard, but only the two test frequencies free from mutual reaction.

Nonlinear distortion can be checked by similar methods. This time the low-frequency test signal is applied with a small input, so that the high-frequency signal has the characteristic sound of a sinusoidal wave. Increase the low-frequency voltage and listen to the high note; if it changes in character, becomes sharper because of introduced harmonics, the speaker has nonlinear distortion.

The oscillator should also be used for testing cabinet speakers. The housing should be mounted on sponge rubber

NEW *Heathkit* VACUUM TUBE VOLTMETER KIT PRINTED CIRCUIT DESIGN

New charcoal gray baked enamel panel with high readability, white lettering. New soft leather gray cabinet. Subdued pilot light indicator.

New printed circuit board for faster, easier construction—exact duplication of Lab development model.



Another outstanding example of continuing Heath Company pioneering and leadership in the kit instrument field. A new **printed circuit** VTVM. New peak-to-peak circuit—new styling and new panel design. A prewired, prefabricated printed circuit board eliminates chassis wiring, cuts assembly time in half, assures duplication of Engineering pilot model specifications, and virtually eliminates possibility of construction error.

CIRCUIT:

A 6AL5 tube operated as a full wave AC input rectifier permits seven peak-to-peak voltage ranges with upper limits of 4000 volts P-P. Just the ticket for you TV servicemen. Voltage divider in the 6AL5 input circuit limits applied AC input to a safe level. This circuitry and the isolation of the meter in the cathode of the 12AU7 bridge circuit affords a high degree of protection to the sensitive 200 microampere meter.

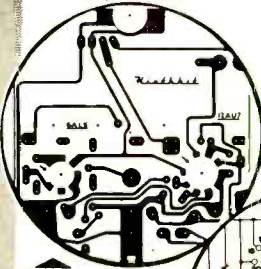

Full wave rectifier in AC input circuit. Read peak-to-peak and RMS volts with upper limit of 4000 P-P and 1500 volts RMS. Voltage divider input circuit.

RANGES:

Seven voltage ranges. 1.5, 5, 15, 50, 150, 500 and 1,500 volts DC and AC RMS. Peak-to-peak ranges 4, 14, 40, 140, 400, 1400, 4000. Ohmmeter ranges X1, X10, X100, X1000, X10K, X100K, X1 meg. Additional features are a db scale, a center scale zero position, and a polarity reversal switch.

IMPORTANT FEATURES:

High impedance 11 megohm input—transformer operated—1% precision resistors, 6AL5 and 12AU7 tube—selenium power rectifier—individual AC and DC calibrations—smoother improved zero adjust control action—new panel styling and color—new placement of pilot light—new positive contact battery mounting—new knobs—test leads included.

The new V-7 also sets the pace as a kit instrument style leader. Smart, good-looking charcoal gray panel and soft leather gray cabinet. High readability panel with sharply contrasting white calibrations. The pleasing, eye catching, modern styling is in harmonious balance with the outstanding circuit design improvements. Easily the best buy in kit instruments.

New easy-to-read open panel layout. Off-on switch now incorporated in the selector switch.

MODEL V-7

\$24⁵⁰

Shpg. Wt. 7 lbs.

New peak-to-peak meter scale—new color harmony—new knobs.

The first kit instrument to offer a labor-saving, error-free printed circuit board. Your instrument an exact wiring replica of Engineering development model.

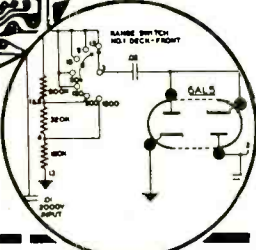

Heathkit AC VACUUM TUBE

VOLTMETER KIT MODEL AV-2

\$29⁵⁰

Shpg. Wt. 5 lbs.

Extreme sensitivity has been emphasized in the design of the Heathkit AC VTVM. Ten full scale RMS ranges are .01, .03, 1, 3, 1, 3, 10, 30, 100, and 300 volts. Frequency response is substantially flat from 10 cycles per second to 50 KC with input impedance of 1 megohm at 1 KC. Will accurately measure as low as 1 millivolt at high impedance. Total db range is -52 db to +52 db. An excellent kit for measuring

the output of phono cartridges and the gain of amplifier stages. Use it also to check power supply ripple, as a sensitive null detector, and for compiling frequency response data. Features one knob operation, 200 microampere Simpson meter and precision resistors.



Heathkit

AUDIO WATTMETER KIT

Read audio power output directly without using external load resistors with the new Heathkit Audio Wattmeter. Built-in non-inductive load resistors provide impedances of 4, 8, 16, and 600 ohms. Flat response from 10 CPS to 250 KC. Full scale power ranges are 0-5 MW, 0-50 MW, 0-500 MW, 0-5 W and 0-50 W. Model AW-1 will operate continuously at 25 watts and has a duty cycle of 3 minutes at 50 watts. Total db range in five positions is -50 db to +48 db, using the standard 1 milliwatt 600 ohms.

MODEL AW-1

\$29⁵⁰

Shpg. Wt. 6 lbs.



Heathkit 30,000 VOLTS DC PROBE KIT

Measure up to 30,000 volts DC with the Heathkit VTVM and the 336 high voltage Probe. Precision resistor provides multiplication factor of 100. Can be used with any 11 megohm input VTVM. Housed in a Polystyrene two color sleek plastic probe body for safety of operation.

No. 336

\$4⁵⁰

Shpg. Wt. 1 lb.



Heathkit PEAK-TO-PEAK PROBE KIT



No. 338-C

\$5⁵⁰

Shpg. Wt. 2 lbs.

Peak-to-peak values not exceeding 80 volts at a DC level of not more than 600 volts, can now be read directly by using 338-C Probe with previous model Heathkit VTVM's or any VTVM with 11 megohm input resistance. Probe construction features a modern printed circuit board for easy assembly. Frequency range 5 KC to 5 MC.

Heathkit RF PROBE KIT

The Heathkit RF Probe will permit the measurement of RF voltages up to 250 MC with an accuracy of $\pm 10\%$. The limits are 30 volts AC and a DC level of 500 volts. Designed for any 11 megohm input VTVM. Modern styling. Polystyrene aluminum housing. Polystyrene insulation, and printed circuit board for easy assembly.



No. 309-C

\$3⁵⁰

Shpg. Wt. 1 lb.

HEATH company
BENTON HARBOR 20,
MICHIGAN

Heathkit 6-12 VOLT BATTERY ELIMINATOR KIT

Here is the new 12 volt Heathkit Battery Eliminator so necessary for modern up-to-date operation of your Service Shop. Furnishes either 6 or 12 volt output which can be selected at the flick of a panel switch. Use the BE-4 to service all of the new 12 volt car radios in addition to the conventional 6 volt models.

RANGES:

This new Battery Eliminator provides two continuously variable output voltage ranges. 0-6 volts D.C. at 10 amperes continuously or 15 amperes maximum intermittent and 0-12 volts D.C. at 5 amperes continuously or 7.5 amperes maximum intermittent. The output voltage is clean and well filtered, as the circuit uses two 10,000 mfd condensers.

The continuously variable voltage output feature is of definite aid in determining the starting point of vibrators, the voltage operating range of oscillator circuits, etc.

OTHER USES:

The controllable low voltage DC supply has many other applications besides primary use in car radio service work. Can be nicely used as a battery charger, or low voltage DC supply for electric trains. Has applications in high gain audio work requiring clean DC filament supply. Can be used for low power electro-plating or as a power supply for battery powered intercommunication systems.

Automatic overload relay—self resetting—fuse protected.

New 18 plate split type heavy duty rectifier unit.



Continuously variable output voltage, either 6 or 12 volt operation.

Constant ammeter and voltmeter monitoring.

MODEL BE-4

\$31.50

Shpg. Wt. 17 lbs.

Heathkit VIBRATOR TESTER KIT



MODEL VT-1

\$14.50

Shpg. Wt. 6 lbs.

This time-saving device will quickly pay for itself in your auto radio service shop. 6 volt vibrators can be checked instantly on the Good—Bad type meter scale. Operation requires only a variable DC voltage from 4 to 6 volts at 4 amperes. Model BE-4 Battery Eliminator is recommended for this application.

Five test sockets provide for the testing of hundreds of interrupter and self-rectifier types. Proper starting voltage is determined easily and accurately. Over-all quality is then unmistakably indicated on the panel mounted meter.

Heathkit IMPEDANCE BRIDGE KIT

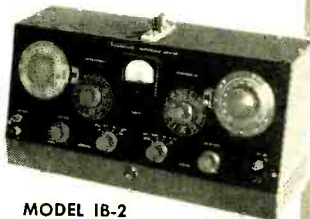

MODEL IB-2

\$59.50

Shpg. Wt. 12 lbs.

The new Heathkit Impedance Bridge features built-in adjustable phase shift oscillator and amplifier. This instrument actually represents four instruments in one compact unit. The Wheatstone bridge for resistance measurements, the Capacity Comparison bridge for capacity measurements, Maxwell bridge for low Q, and Hay bridge for high Q measurements.

DESIGN:

Panel provisions for external generator use. A new two section CRL dial, provides ten separate "units." Ten separate units switch settings and fractions of units are read on a continuously variable calibrated control. A special minimum capacity shielded and balanced impedance matching transformer between the generator and bridge circuit is automatically switched to provide correct load operation of the generator circuit. The instrument uses 1/2% precision resistors and condensers in all measurement circuits.

Heathkit VARIABLE VOLTAGE ISOLATION TRANSFORMER KIT

Variable output voltage between 90 and 130 volts AC. Rated at 100 volt—amperes continuously and 200 volt—amperes intermittently. The principle function of the Heathkit Isolation Transformer is to isolate the circuit being tested from line interference being caused by motors, appliances, etc. It works backward too by isolating such devices from the line.

Many other uses, especially with AC-DC type circuits. Do not confuse the Heathkit Isolation Transformer with the hazardous auto transformer type line voltage boosters.



MODEL IT-1

\$16.50

Shpg. Wt. 10 lbs.

HEATH company
BENTON HARBOR 20,
MICHIGAN

AUDIO—HIGH FIDELITY

to isolate it from its surroundings. The frequency range is swept, with constant input. Unevenness in the bass usually results from defects of housing design; unevenness in the treble from the acoustics of the test room. Multiple-unit speaker systems should be carefully explored at and near the crossover frequency. Not all this test equipment is available to the average listener. However, he can use gliding-tone test records, having satisfied himself that his pickup is free from resonances, tracks properly, and does not introduce harmonics at low frequencies. If a gliding-tone wobble record can be found, that is the best type to use.

It is difficult to determine the quality of a speaker by listening to it in a show-room. Apart from the speaker there are three unknowns—the pickup, the demonstration record, and the room acoustics. In addition the demonstrator may be using the tone controls to suit his own purposes; almost invariably the demonstration is given at too high volume, a trick of the trade, since the ear subconsciously shuts down its critical faculties in the presence of high volume. A good speaker driven by good equipment will show up very well at low volumes, and if under these conditions there is a lack of bass or extreme treble the speaker should be rejected. Thumping bass is not high fidelity. Some speaker systems sound very impressive because of a well-developed bass resonance, either in the driver unit or the housing. This, however, is "one-note thump," and a discriminating listener will come in time to hate it.

But how is it possible to come to a decision regarding any speaker in the absence of test gear, reliable information from the dealer or manufacturer, and knowledge of the room acoustics? I fear there is only one way, yet it is within the reach of any listener, or non-technician. It is an innate characteristic of the human brain to become easily tired by inharmonious contacts with the outside world. If you get a small piece of grit in your shoe, sooner or later you will be unable to put up with it any longer; if you wish to work or relax in the presence of noise, you can neither work well nor relax well. As a listener you may not recognize distortion (inharmonic sound) as such, but your subconscious will.

The supreme test, therefore, of an audio installation is to listen to it with close attention for a considerable time. If you go to a concert you are prepared to sit and relax, even close your eyes, for as long as three hours, and at the end feel inspired, entertained, and conscious that something has been well done. Try listening to a complete symphony concert in a darkened room (so that the other senses do not distract you). If after three hours you feel tired, you can be reasonably certain that there was something wrong with the record, the pickup, the amplifier—or the speaker. **END**

NEW *Heathkit* TV ALIGNMENT GENERATOR KIT

Here is the most radically improved Sweep Generator in the history of the TV service industry. The basic design follows latest high frequency techniques which result in a combination of performance features not found in any other sweep generator.

SWEEP:

Sweep action is obtained electronically through the use of a newly developed controllable inductor, thereby eliminating all moving parts with their resultant hum, vibration, fatigue, etc. Frequency coverage entirely on fundamentals, is continuous from 4 MC to 220 MC at an output level well over a measurable .1 volt.

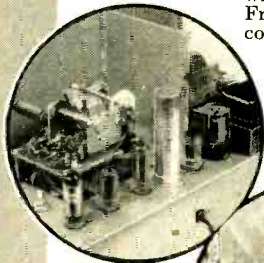

Triple marker system, 4.5 MC crystal controlled marker—continuously variable marker—provisions for external marker.

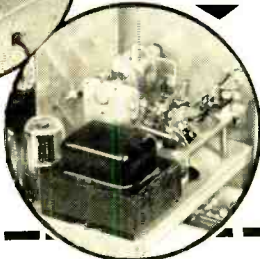

Automatic amplitude control circuit—constant output voltage regulated power supply

MARKER:

The same instrument incorporates a triple marker system with a crystal controlled reference. A variable marker provides accurate coverage from 19 to 60 MC on fundamentals, and 57 to 180 MC on calibrated harmonics. A separate fixed crystal controlled 4.5 MC marker can be used for checking IF, band-pass, calibration, reference, etc. Provisions are also made for external marker use. A 4.5 MC crystal is supplied with the kit.

POWER SUPPLY:

The transformer operated Power Supply features voltage regulation for stable oscillator operation. Three sets of shielded cables are furnished with the kit. Sweep range is completely and smoothly controllable from zero up to a maximum of 50 MC, depending upon base frequency.

Here is a TV Sweep Generator that truly no serviceman can afford to be without for rapid, accurate, TV alignment work.

Controllable inductor sweep oscillator with output entirely on fundamentals.

Triple marker system 4.5 MC crystal controlled—3 sets of cables included.

Electronically operated, smoothly controlled, continuously variable sweep circuit. No vibration, hum or noise.



Frequency coverage 4 MC—220 MC continuous including FM spectrum. RF output well over .1 volt.

MODEL TS-3

\$44.50

Shpg. Wt. 13 lbs.

NEW *Heathkit* SIGNAL GENERATOR KIT



MODEL SG-8

\$19.50 Shpg. Wt. 8 lbs.

The new Heathkit service type Signal Generator, Model SG-8 incorporates many design features not usually found in this instrument price range. Frequency coverage is from 160 KC to 110 MC in five ranges, all on fundamentals, with useful calibrated harmonics up to 220 MC. The RF output level is well in excess of 100,000 microvolts throughout the frequency range. The oscillator circuit consists of a twin triode tube, one-half used as a Colpitts oscillator, and the other half as a cathode follower output which acts as a buffer between the oscillator and external load, thereby eliminating oscillator frequency shift usually caused by external loading.

All coils are factory wound and adjusted, thereby completely eliminating the need for individual calibration and the use of additional calibrating equipment. The stable, low impedance output, features step and variable attenuation for complete control of RF level. A separate 6C4 triode acts as a 400 cycle sine wave oscillator, and a panel mounted switching system permits choice of either external or internal modulation.

Heathkit LABORATORY GENERATOR KIT



MODEL LG-1

\$39.50

Shpg. Wt. 16 lbs.

The new Heathkit Laboratory type Signal Generator definitely establishes a new performance standard for a kit instrument. An outstanding feature involves the use of a panel mounted 200 microampere meter calibrated both in microvolts and percent modulation, thereby providing a definite reference level for using the Signal Generator in design work, gain measurements, selectivity, frequency response checks.

DESIGN:

Additional design features are copper plated shield enclosure for oscillator and buffer stages resulting in effective double shielding. Fibre panel control shaft extensions in RF carrying circuits, thorough AC line filtering, careful shielding of the attenuator network, voltage regulated B plus supply, selenium rectifier, etc.

RANGES:

Frequency coverage from 150 KC to 30 MC all on fundamentals in five separate ranges. Output voltage .1 volt with provisions for metered external or internal modulation. Output impedance termination 50 ohms. Transformer operated power supply.

Investigate the many dollar stretching features offered by the LG-1 before investing in any generator for Laboratory or Service work.

NEW *Heathkit* BAR GENERATOR KIT



MODEL BG-1

\$14.50 Shpg. Wt. 4 lbs.

The Heathkit BG-1 produces a series of horizontal or vertical bars on a TV screen. Since these bars are equally spaced, they will quickly indicate picture linearity of the receiver under test without waiting for transmitted test patterns. Panel switch provides "standby—horizontal and vertical position." The oscillator unit uses a 12AT7 twin triode for the RF oscillator and video carrier frequencies. A neon relaxation oscillator provides low frequency for vertical linearity tests. The instrument will also provide an indication of horizontal and vertical sync circuit stability as well as overall picture size. Operation is simple and merely requires connection to the TV receiver antenna terminal. Transformer operated for safety.

HEATH company
BENTON HARBOR 20,
MICHIGAN

Heathkit
VISUAL-AURAL
**SIGNAL-TRACER
KIT**

The new Heathkit Visual-Aural Signal Tracer features a special high gain RF input channel used in conjunction with a newly designed wide frequency range demodulator probe. High RF sensitivity permits signal tracing from the receiver antenna input. Separate low gain channel and probe available for audio circuit exploration. Both input channels are constantly monitored by an electron ray beam indicator so that visual as well as aural indications may be obtained.

NOISE LOCATOR:

A decidedly unusual feature is a noise locator circuit used in conjunction with the audio probe. With this system, a DC potential is applied to a suspected circuit component and the action of the voltage in the component can be seen as well as heard. Invaluable for ferreting out noisy or intermittent condensers, noisy resistors, controls, IF and power transformers, etc.

WATTMETER:

Built-in calibrated wattmeter circuit will prove useful for quick preliminary check of total wattage consumption of equipment under test. Separate panel terminals provide external use of the speaker or output transformer for substitution purposes. Saves valuable service time by eliminating the necessity for speaker removal on every service job. The same panel terminals also provide easy access to a well filtered B plus supply for external use. Don't overlook the many interesting service possibilities provided through the use of this instrument, and let the Signal Tracer work for you by saving time and money.

Substitution test speaker—utility amplifier.
Noise locator circuit—calibrated wattmeter.

RF and audio probes supplied along with necessary test leads.

Visual and aural signal tracing.

MODEL T-3
\$23⁵⁰
Shpg. Wt. 9 lbs.



Heathkit **CONDENSER CHECKER KIT**



MODEL C-3
\$19⁵⁰ Shpg. Wt. 7 lbs.

Here is a handy test instrument for any Service Shop. Unknown values of capacity and resistance are quickly determined on the direct reading condenser checker dial. Capacity is measured in four ranges from .001 mfd to 1000 mfd. Resistance in the range from 100 ohms to 5 megohms.

DC polarizing voltages of 25, 150, 250, 350, and 450 volts are available for leakage tests on all types of condensers. For electrolytics, a power factor control is provided to balance out inherent leakage and to indicate directly the power factor of a condenser under test. Proper balancing of the AC bridge is reflected in the degree of closure of an electron beam indicator tube.

Model C-3 uses a transformer operated power supply, spring return leakage test switch, and a convenient combination of panel scales for all readings. Test leads are furnished in addition to precision components for calibrating purposes. Quick and easy to operate, the Heathkit Condenser Checker will save valuable time and increase your Shop efficiency.

Heathkit **"Q" METER KIT**



MODEL QM-1
\$44⁵⁰
Shpg. Wt. 14 lbs.

The Heathkit QM-1 represents the first practical popular priced Q meter available within the price range of schools, laboratories, TV service men, and experimenters. This instrument will enable the operator to simulate conditions encountered in practical circuits and to measure the performance of coils or condensers at the operating frequencies actually encountered. All indications of value are read directly on the 4 1/2" 50 microampere Simpson calibrated meter scale. Measures Q of condensers, RF resistance, and the distributed capacity of coils. Oscillator section supplies RF frequencies 150 KC to 18 MC in four ranges. Calibrate capacity with range of 40 MMF to 450 MMF with vernier of ±3 MMF. Investigate the many services this instrument can perform for you.

Heathkit **AUDIO OSCILLATOR KIT**

MODEL AO-1
\$24⁵⁰
Shpg. Wt. 10 lbs.



The Heathkit Audio Oscillator will produce both sine and square waves within the frequency range from 20 CPS to 20 KC in three ranges. Thermistor controlled linearity results in a variation of no more than ±1 db in a 10 volt (no load) variable output level. There will be less than .6% distortion from 100 CPS throughout the audible range. Low impedance 600 ohm output. Precision 1% resistors, used in the range multiplier circuits to provide accurate calibration.

HEATH company
BENTON HARBOR 20,
MICHIGAN

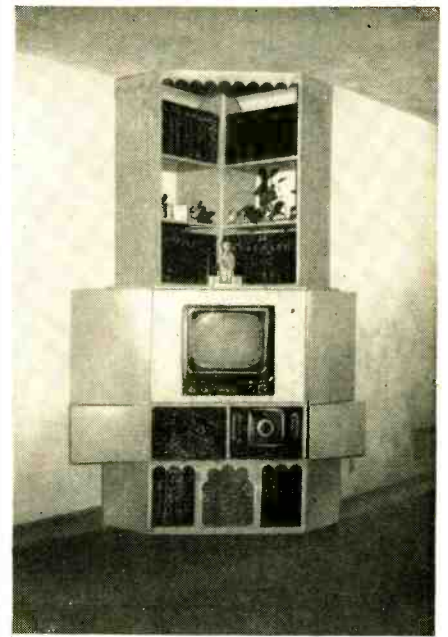

Built-in radio-phon-combination.

**AN INTERESTING
CUSTOM INSTALLATION**

WHAT about that odd corner that most of you small home owners would like to put to use? I had one in my living room and I believe my solution will interest you. I built in a radio-phonograph-television cabinet (see photo).

The entire cabinet consists of 3/4-inch white-pine plywood with 1/4-inch plywood used for facing the cabinet. The television set is a 17-inch Philco table model (the space for the television set is large enough for a 21-inch model). The movable panel that encloses the TV receiver has two switches on it: one for the speaker, and one for changing antennas (I have two transmission lines hooked to the set).

The Zenith radio-phon combination and the 12-inch speaker came from a Zenith radio-phonograph floor model cabinet.

Both the radio and phonograph are built on sliding shelves, greatly simplifying repairs. The speaker—now at floor level—has improved the sound of the TV set that formerly had a 4-inch side speaker. The speaker is used for the radio and phonograph as well.

The space above the television set is used to store record albums. The shelves are cut out at the rear so they allow proper circulation of air from bottom to top. There is an opening on each side of the speaker and on top of the record album cabinet.

An electric outlet is hidden from view by the cabinet. It can be reached through the air vent on the left side. The two lead-ins from the outside antenna come up through the basement and are entirely hidden from view.

Now, not only do I have a convenient entertainment combination, but a handsome piece of furniture to boot.—*Alvin R. Wisniewski.*

Heathkit TUBE CHECKER KIT

Illuminated for easy reading and quick identification of chart reference.

Improved smooth running roll chart mechanical action.

Simplified construction—new harness type wiring—closer tolerance resistors.

Smart, professional appearance—available in counter or portable models.

Three color Good—H.A.D. 4 1/2" plastic cased meter.

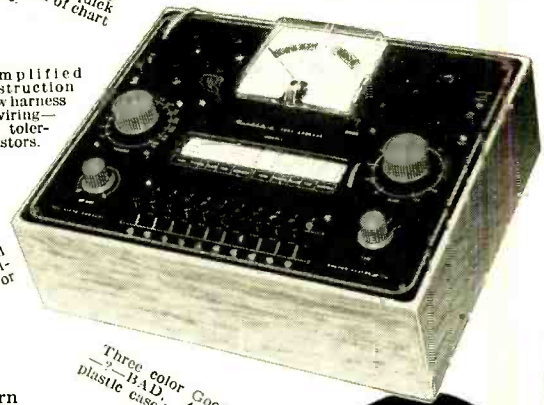

The Heathkit TC-2 Tube Checker was primarily designed for the convenience of radio and TV servicemen and will check the operating quality of tubes commonly encountered in this type of work. Test set-up procedure is simplified, rapid, and flexible. Panel sockets accommodate 4, 5, 6, and 7 pin tubes, octal and loctal, 7 and 9 pin miniatures, 5 pin Hytron, and a blank socket for new tubes. Built-in neon short indicator, individual 3-position lever switch for each tube element, spring return test switch, 14 filament voltage ranges, and line-set control to compensate for supply voltage variations, all represent features of the TC-2.

Heathkit PORTABLE TUBE CHECKER KIT

The portable model is supplied with a strikingly attractive two-tone cabinet finished in rich maroon proxylin impregnated fabric covering with a contrasting gray on the inside of the detachable cover.

MODEL TC-2P

\$34⁵⁰

Shpg. Wt.
15 lbs.



Results of tube tests are read directly from the large 4 1/2" Simpson 3-color meter. Checks emission, shorted elements, open elements, and continuity. Wiring procedure has been simplified through the use of multi-wired color coded cable providing a harness type installation between tube sockets and lever switches. This procedure insures standard assembly and imparts a "factory built" appearance to the instrument. New Construction Manual furnishes detailed information regarding tube set-up procedure for testing of new or unlisted tube types. No delay necessary for release of factory data.

MODEL TC-2
\$29⁵⁰
Shpg. Wt.
12 lbs.

Heathkit REGULATED POWER SUPPLY KIT



MODEL PS-2

\$33⁵⁰ Shpg. Wt.
15 lbs.

Here is a source of regulated D.C. voltage for circuit development work. Power supply voltage and current drain to the circuit under test are constantly monitored by the 4 1/2" panel mounted meter. Separate 6.3 volt at 4 ampere A.C. filament source available. The regulated and variable output voltage will be constant over wide load variations, and hum ripple will not exceed .012% at 250 volts under a 50 MA load. Completely isolated circuit, standby switch, and other desirable features, make the Model PS-2 extremely useful in a wide variety of applications.

Heathkit TV PICTURE TUBE TEST ADAPTER

The Heathkit TV Picture Tube Test Adapter used with the Heathkit Tube Checker Kit, will quickly check picture tubes for emission, shorts, etc. and determine tube quality. Consists of standard 12-pin TV tube socket, four feet of cable, octal socket connector, and data sheet.



No. 355

\$4⁵⁰ Shpg. Wt.
1 lb.

Heathkit DECADE RESISTANCE KIT



MODEL DR-1

\$19⁵⁰

Shpg. Wt.
4 lbs.

Twenty 1% resistors are decaded in 1 ohm steps to provide any value between 1 ohm and 99,999 ohms. Sturdy ceramic switches with silver plated contacts insure reliable service. Use the Decade Resistance in bridge circuits, meter multipliers, calibrations, or any application requiring a wide range of precision resistance values.

Heathkit AUDIO GENERATOR KIT

Here is an Audio Generator with features generally found only in the most expensive instruments. Sine wave coverage from 20 cycles to 1 Megacycle—response flat ± 1 db from 20 cycles to 400 Kc—continuously variable and step attenuated output. Because the output voltage is relatively constant over wide frequency ranges, the AG-8 is ideal for running frequency response curves in audio circuits. Once set by means of the attenuator, this voltage may be relied upon for accuracy within ± 1 db. Instrument features low impedance 600 ohm output circuit and distortion less than .4 of 1% from 100 CPS through audible range.



MODEL AG-8

\$29⁵⁰

Shpg. Wt. 11 lbs.

Heathkit DECADE CONDENSER KIT

The Heathkit Decade Condenser provides a ready source of capacity values from 100 mmf to .111 mfd inclusive in capacity steps of 100 mmf. Silver plated contacts on husky ceramic switches, assure positive contact for each switch position. Precision silver mica condensers $\pm 1\%$ accuracy for close tolerance accurate work.

MODEL DC-1

\$16⁵⁰

Shpg. Wt.
3 lbs.



HEATH company
BENTON HARBOR 20,
MICHIGAN

NEW *Heathkit* HIGH FIDELITY PREAMPLIFIER KIT

Here is the exciting new Heathkit Preamplifier with all of the features you Audiophiles have asked for and at a down-to-earth price level. Beautiful satin gold baked enamel finish, striking control knobs and arrangement, attractive custom appearance and entirely functional design.

DESIGN:

Uses three twin triode tubes in a shock mounted chassis, 2-12AX7 and 1-12AU7. Features tube shielding, plastic sealed color coded capacitors, smooth acting controls, good filtering, excellent decoupling, low hum and noise level, and all aluminum cabinet. Special balancing control for absolute minimum hum level. Cathode follower, low impedance output circuit for complete installation flexibility.

SPECIFICATIONS:

Provides five switch selected inputs, 3 high level, and two low level, each with individual level controls—4 position LP, RIAA, AES, and early 78 equalization switch—4 position roll-off switch, 8, 12, 16 with one flat position. Separate tone controls, bass 18 db boost and 12 db cut at 50 CPS, treble 15 db boost, and 20 db cut at 15,000 CPS. Power re-

Equalization for LP, RIAA, AES, and early 78.

Separate bass and treble tone controls—special hum control.



Cathode follower low impedance output circuit.

Beautiful, modern appearance, blends with any interior or color scheme.

Five switch selected inputs with individual level controls.

quirements from Heathkit Williamson Type Amplifier power supply 6.3 volts AC at 1 ampere, and 300 volts DC at 10 MA. Over-all dimensions 12 $\frac{1}{2}$ " wide x 5 $\frac{1}{2}$ " deep x 3 $\frac{3}{8}$ " high.

APPLICATION:

The new Heathkit WA-P2 Preamplifier has been designed to operate with any of the Heathkit Williamson Type Amplifiers and is directly interchangeable with the previous Model WA-P1 Preamplifier unit. Order your kit today and enjoy completely smooth control over the operation of your Hi-Fi system. Obtain the exact tonal balance of bass and treble with the precise degree of equalization you want. Note that the design of the WA-P2 accommodates the newly established RIAA curve.

MODEL WA-P2

\$19⁷⁵

Shpg. Wt. 7 lbs.

HAM EQUIPMENT

Single knob band switching—pre-wound coils.



Crystal or VFO excitation—metered operation. 52 Ohm coaxial output—built-in power supply.

MODEL AT-1

\$29⁵⁰

Shpg. Wt. 16 lbs.

filter, good shielding and a 52 ohm coaxial output. The 425 volt, 100 milliamper power supply and 5U4 rectifier are more than adequate for the 6AG7 oscillator multiplier and 6L6 amplifier doubler.

Heathkit AMATEUR TRANSMITTER KIT

The Heathkit AT-1 Transmitter has established a high reputation and has been enthusiastically accepted by hundreds of experienced operators as well as beginners. Power input up to 35 watts for the novice and suitable as a standby exciter for your higher powered rig later on.

Model AT-1 can be crystal or VFO excited and operates on 80, 40, 20, 15, 11, and 10 meters. The pre-wound coils with the oscillator and amplifier are switched simultaneously by the rugged band switch. Meter switch allows a reading of the final grid and plate current on the panel mounted meter. Modulator input and VFO power sockets are provided as well as a key jack for CW operation. Other features include a crystal socket, standby switch, key click filter, AC line filter, good shielding and a 52 ohm coaxial output. The 425 volt, 100 milliamper power supply and 5U4 rectifier are more than adequate for the 6AG7 oscillator multiplier and 6L6 amplifier doubler.

Copper plated chassis—aluminum cabinet—easy to build.



Smooth acting illuminated and precalibrated dial.

Brand NEW HEATHKIT VFO KIT

The new Heathkit VFO is the perfect companion to the Heathkit Model AT-1 Transmitter and it has sufficient output to drive any multi-stage transmitter of modern design. Good mechanical and electrical design insures operating stability. Coils are wound on stable, heavy duty, ceramic forms using Litz or double cellulose wire coated with Polystyrene cement and baked for humidity protection. Variable capacitor of differential type construction, especially designed for maximum bandspread. Kit is furnished with a carefully precalibrated scale which provides well over two feet of scale length. Smooth acting vernier reduction drive and illuminated dial provides easy tuning and zero beating.

Seven band coverage 160 through 10 mft output.

6AU6 electron coupled Clapp oscillator and OA2 voltage regulator.

MODEL VF-1

\$19⁵⁰

Shpg. Wt. 7 lbs.

Power requirements 6.3 volts AC at .45 amperes, and 250 volts DC at 15 mls. Just plug it into the power receptacle provided on the rear of the AT-1 Transmitter. Seven band coverage 160 through 10 meters with 10 volt average RF output. Uses 6AU6 electron coupled Clapp oscillator and OA2 voltage regulator.

Heathkit GRID DIP METER KIT

The invaluable instrument for Hams, servicemen and experimenters. Useful in TV service work, for alignment of traps, filters, IF stages, peaking compensation networks, etc. Locates spurious oscillation, provides a relative indication of power in transmitter stages. Use it for neutralization, locating parasites, correcting TVI, measuring CL and Q of components, and determining RF circuit resonant frequencies. The variable meter sensitivity control, headphone jack, 500 microampere Simpson meter, continuous frequency coverage from 2 MC to 250 MC. Pre-wound coil kit and rack included.

LOW FREQUENCY COILS:

Low frequency range extended to 355 KC by the use of two additional coils. Complete with dial correlation curves. Set 341-A for GD-1B and set 341 for GD-1A. Shpg. wt. 1 lb. Price \$3.00



MODEL GD-1B

\$19⁵⁰

Shpg. Wt. 4 lbs.



MODEL AM-1

\$14⁵⁰

Shpg. Wt. 2 lbs.

Determine antenna resonance and resistance, transmission line surge impedance, and receiver input impedance. Works with one-half and one-quarter wave lines, half wave and folded dipoles, harmonic mobile and beam antennas. Resistance type SWR bridge—100 microampere meter—frequency range 0-150 MC—impedance range 0-600 ohms.

Heathkit ANTENNA IMPEDANCE METER KIT



MODEL AC-1

\$14⁵⁰

Shpg. Wt. 4 lbs.

Heathkit ANTENNA COUPLER KIT

For the Heathkit AT-1 Transmitter or any comparable Amateur Transmitter. Will handle power up to 75 watts at its 52 ohm coaxial input. Matches a wide range of antenna impedances with its L type tuning network and neon indicator. A tapped inductance provides coarse adjustment and a transmitting type variable condenser sets it "right on the nose." Will operate on the 10 through 80 meter bands.

HEATH company
BENTON HARBOR 20,
MICHIGAN

New LOW PRICED HEATHKIT SINGLE UNIT Williamson Type High Fidelity AMPLIFIER KIT

Here is the newest Heathkit Hi-Fi Amplifier at the lowest price ever quoted for a complete Williamson Type Amplifier circuit. The W-4 Model has been designed for single chassis construction, and only for the new Chicago Transformer Company Model BO-13 "super range" high fidelity output transformer. This transformer, a new development in the Hi-Fi field, is being offered at substantial saving over transformers of comparable quality. It is outstanding in performance and on the basis of our tests, we find it equal in every respect to transformers used in the W-2 and W-3 Heathkit series.

LOW PRICES:

Through utilization of a single chassis with resultant economy obtained through elimination of duplicate sheet metal fabrication, connecting cables, plugs, sockets, and a new Chicago "super range" output transformer, a 20% price reduction has been made possible without sacrificing kit quality.

COMPONENTS:

The new Heathkit W-4 uses the same heavy duty power transformer and choke. It has all of the features of previous models including individual jacks and a wire wound control to balance the output tubes—plastic high quality capacitors and the exact circuitry previously utilized in Williamson Type Amplifiers. Intermodulation distortion and harmonic distortion are both at the same low level as in the W-2 and W-3 models.

CONSTRUCTION:

Here is the opportunity for even the economy minded Hi-Fi enthusiast to enjoy all of the advantages offered through Hi-Fi reproduction of fine recorded music. Simplified step-by-step Construction Manual completely eliminates necessity of electronic knowledge or special equipment. Assemble this Amplifier in a few pleasant hours.

Rugged, heavy duty,
single chassis con-
struction.

Output impedances
4, 8, and 16 ohms.

Standard
brand com-
ponents used,
no sacrifice of
quality.

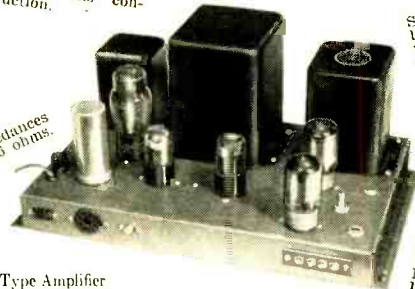

Send for
free booklet
"High
Fidelity
Especially
For You."

Lowest price high quality
Williamson Type Ampli-
fier ever offered.

COMBINATIONS AVAILABLE

W-4M with Chicago "super-range" trans-
former only. Single chassis main amplifier
and power supply. Shipping **\$39.75**
weight 28 lbs. Express only

COMBINATION W-4 with Chicago
"super-range" transformer only includes
single chassis main amplifier and power sup-
ply with WA-P2 preamplifier **\$59.50**
kit. Shpg. wt. 35 lbs. Express only

NEW Heathkit 20 WATT High Fidelity AMPLIFIER KIT

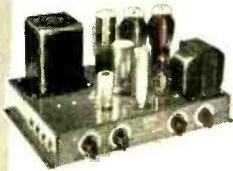

MODEL A-9B

\$35⁵⁰

Shpg. Wt. 24 lbs.

In keeping with the progressive policy of the Heath Company, further improvement has been made in the already famous Heathkit High Fidelity 20 Watt Amplifier. Additional reserve power has been obtained by using a heavier power transformer. A new output transformer designed and manufactured especially for the Heath Company, now provides output impedances of 4, 8, 16 and 500 ohms. The harmonic distortion level will not exceed 1% at the rated output.

FEATURES:

Outstanding features of the Heathkit 20 watt Amplifier include frequency response of ± 1 db from 20 CPS to 20 KC. Separate (boost and cut) bass and treble tone controls. Four switch selected input jacks and a special hum balancing control. Flexibility is emphasized in the input circuits and proper equalization for all input devices is incorporated.

TUBE LINEUP:

12AX7 magnetic preamplifier and first audio amplifier. 12AU7 two stage amplifier with tone controls. 12AU7 voltage amplifier and phase splitter. Two 6L6 push-pull beam power output and 5U4G rectifier.

The Heathkit Model A-9B is excellent for custom installation and is designed for outstanding service at a very reasonable cost.

Heathkit SIX WATT AMPLIFIER KIT



MODEL A-7B

\$15⁵⁰

Shpg. Wt. 10 lbs.

An outstanding value, this economically priced 5 watt Amplifier is capable of performance expected only in much more expensive units. Only 2 or 3 watts output will ever be used in normal home applications and Model A-7B will be more than adequate for this purpose.

SPECIFICATIONS:

Two switch selected inputs are available for crystal and ceramic phono pickups, tuner, TV audio, tape recorder, and carbon type microphone. Model A-7B features separate bass and treble tone controls, push-pull balanced output stages, output impedances of 4, 8, and 15 ohms, and extremely wide frequency range $\pm 1\frac{1}{2}$ db from 20 CPS to 20 KC. Not just a souped up AC-DC job. Full wave rectification, transformer operated power supply and good filtering, result in exceptionally low hum level.

MODEL A-7C

Provides a preamplifier stage and proper compensation for the variable reluctance cartridge and low level microphone. \$17.50

Heathkit WILLIAMSON TYPE AMPLIFIER KIT

Here is the famous kit form Williamson Type high fidelity Amplifier that has deservedly earned highest praise from every strata of Hi-Fi music lovers. Virtually distortionless, clean musical reproduction, full range frequency response, and more than adequate power reserve.

OUTPUT TRANSFORMERS:

This outstanding Williamson Type Hi-Fidelity Amplifier is supplied with the famous Aerosound TO-300 output transformer. This quality transformer features the popular "ultra-linear" output circuit for clean maximum power level. Separate chassis for amplifier and power supply.

SPECIFICATIONS:

Frequency response within 1 db from 10 cycles to 100,000 cycles. Harmonic distortion at 5 watt output less than .5% between 20 cycles and 20,000 cycles. 1M distortion at 5 watts equivalent output .5% using 60 and 3,000 cycles. Output impedances of 4, 8, or 16 ohms. Overall dimensions for each unit 7" high x 5 $\frac{1}{2}$ " wide x 11 $\frac{1}{2}$ " long.

CONSTRUCTION MANUAL:

This fine kit is supplied with a completely detailed step-by-step Construction Manual and the only effort required is the assembly and wiring of the pre-engineered kit. Even the complete novice can successfully construct this Amplifier and have fun building it.

COMBINATIONS AVAILABLE:

W-3 Amplifier Kit (Includes Main Amplifier with Aerosound Output Transformer. Power Supply and WA-P2 Preamplifier.) Shipping weight 37 lbs. Shipped express only. **\$69.50**

W-3M Amplifier Kit (Includes Main Amplifier with Aerosound Output Transformer and Power Supply.) Shipping weight 29 lbs. Express only **\$49.75**

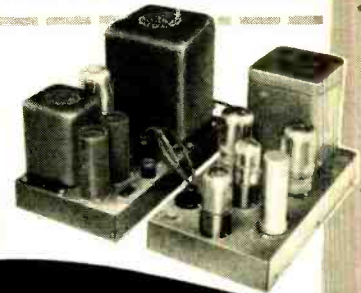

HEATH company
BENTON HARBOR 20,
MICHIGAN

DUAL-PURPOSE LIMITER AMPLIFIER

By HILTON L. REMLEY

By limiting audio levels, this instrument has many uses in broadcasting, receiving, and general audio work

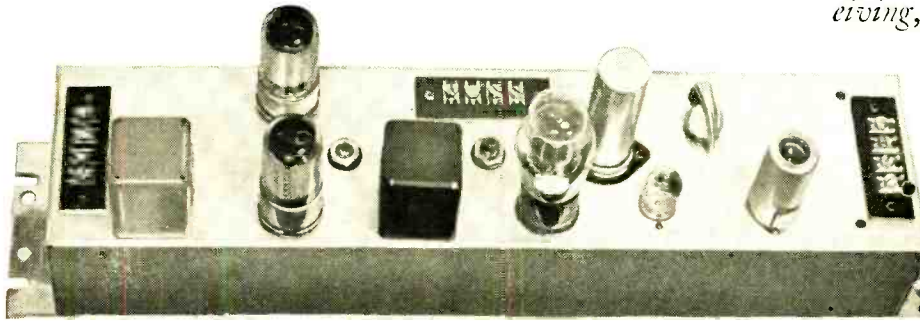

The limiter amplifier. Terminal strips permit convenient connections.

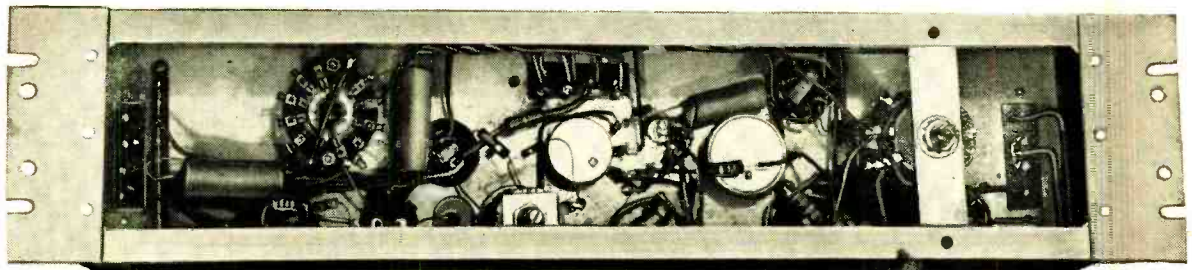

Underchassis view of limiter amplifier. Unit is for rack mounting.

THE limiter amplifier was built to overcome an objectionable trend in the television broadcasting industry. The great majority of television stations appear to be operating without limiter amplifiers and an overwhelming number of programs seem to have the audio level increased by several db for the commercials, which makes for annoyance in listening. Just as one thinks he has the audio level adjusted for his pleasure, along comes the commercial and blasts him out of his complacency. It seems useless to appeal to the stations—they always say that they have to put across the message. After putting up with this for some time, I finally decided to construct a limiter amplifier which would do away with this problem on the receiver end.

The television set I used has the audio output fed at 600 ohms to a high-fidelity amplifier, which in turn feeds a high-fidelity speaker system. Thus, by inserting the limiter between the television set and the power amplifier, it was not necessary to add any gain to the circuit. Accordingly, it was decided to make the limiter a single controlled stage, with balanced input and output. Use of 6SK7's in the controlled stage was decided upon after checking the characteristics of available tubes. This turned out to be a happy choice, since later frequency and distortion measurements indicated low distortion under

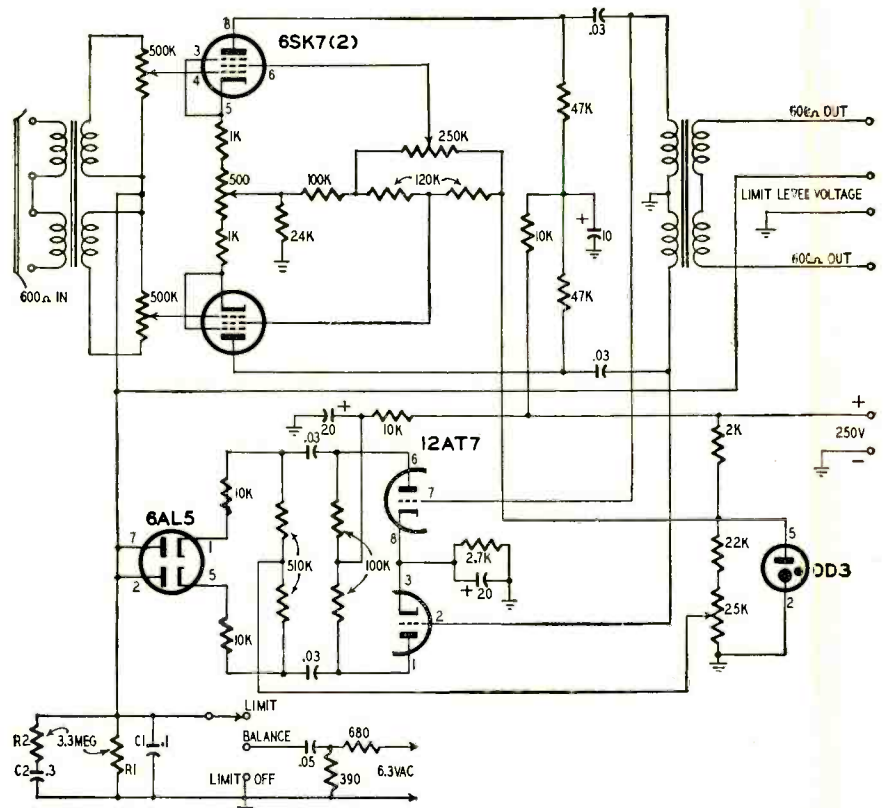

Schematic of the limiter-amplifier. External power supply is used.

*Here is the finest
FM-AM tuner ever made*

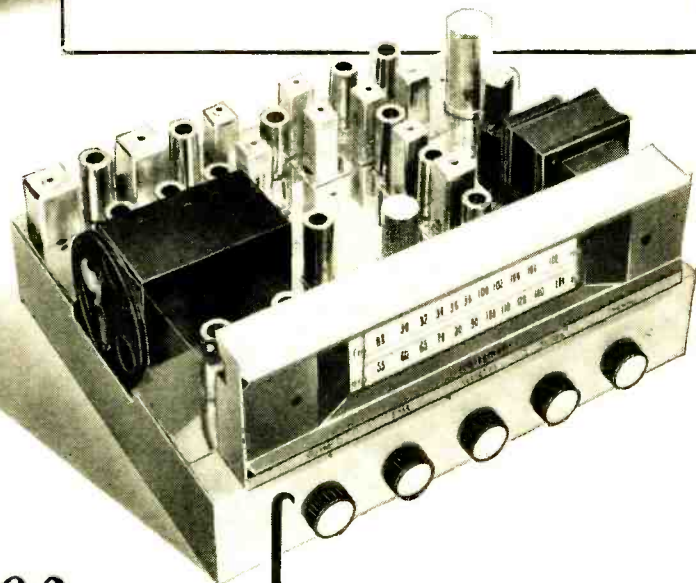

THE *New* Craftsmen C1000

But the C1000 is far more than just a tuner—it's the complete control center for your High Fidelity system. Combined in one chassis is a complete preamplifier with four positions of record equalization, flexible tone controls, input circuits for your television receiver, tape recorder and phonograph . . . plus the most sensitive tuner ever offered.

- New* FM sensitivity: 3 mv for Audio limiting (40 db quieting)
- New* AM sensitivity: 1 mv for 20 db signal to noise ratio.
- New* Separate Oscillators and Convertors for FM & AM.
- New* Dual AM band width positions: Sharp for DX'ing and Broad for High Fidelity
- New* Low noise antenna input for AM.
- New* Preamplifier circuit featuring grounded cathode feedback equalization.
- New* Four position switch for accurate record equalization.
- New* Low distortion: Only 0.05% IM at 1½ volts output.
- New* Tape recorder output, independent of monitoring level.
- New* Semi-Military construction for maximum ruggedness.

Plus All the features you expect in a Craftsmen tuner: Automatic Frequency Control, flywheel tuning, Cathode follower outputs, separate RF amplifiers for FM & AM and engineering you can trust.

Hear the Difference

AT YOUR HIGH FIDELITY DEALER
OR RADIO PARTS DISTRIBUTOR . . .

For complete information ask for Bulletin #5.

The Radio Craftsmen, Inc., Dept. G10
4403 N. Ravenswood Ave., Chicago 40, Illinois

AUDIO—HIGH FIDELITY

adverse operating conditions and yet provided adequate limiting range.

Since the limiter was to limit over a considerable range, I decided to provide exact input tube balance, with some rapid system for obtaining such balance. Choice of balanced tubes is a help, but not the whole answer. I provided control of both bias and screen voltages. The bias is balanced by 500,000-ohm potentiometers in the grid circuits of the 6SK7's. The screen voltage is adjusted by a 250,000-ohm potentiometer controlling one screen only. Two 6SK7's can be so far out of balance that they cannot be balanced by this means. Interchanging tubes or direct replacement of one tube will probably overcome this difficulty. There is a 3-position switch, one position of which is used to set the tube balance. The 6.3-volt supply feeds into a voltage divider to provide a small 60-cycle voltage. This is fed through a .05- μ f capacitor to the center of the input transformer secondary. This provides an in-phase signal on the control grids of the 6SK7's. If the two tubes have equal amplification with an in-phase voltage of equal amplitude at each grid, there will be equal but out-of-phase voltages on the plates. Thus with the switch set on BALANCE, balance is exact when the output is zero. To balance the 6SK7's, the limiter output is connected through another amplifier to a volume indicator, while the bias and screen controls are adjusted for minimum output. The switch also has a position which grounds the bias to the 6SK7's, giving linear amplification with no limiting.

The attack and release time of the limiter should receive some consideration. By use of a dual R-C circuit, attack time is rapid, while release time is prolonged. The parallel R1-C1 combination of 3.3 megohms and 0.1 μ f charges very quickly; in the order of 0.00006 second, and discharges in about $\frac{1}{3}$ second. By adding R2-C2 of 3.3 megohms and 0.3 μ f in series across the R1-C1 combination, R2-C2 will charge slowly; in a little less than 1 second, and discharge even more slowly, in something like 2 seconds. Thus on very short duration peaks only R1-C1 will be effective, since R2-C2 does not have time to charge, and recovery time is short. On continued peaks, however, R2-C2 charges, and the recovery time is lengthened. This prevents the "thumping" and "breathing" that occurs on some limiters and yet does not "dig a hole" in the program as would a quick-attack and long-release type limiter.

By using the 12AT7 amplifier ahead of the 6AL5 rectifier we get much more rapid attack. Were this stage left out, isolation and attack time would both be inadequate, resulting in reduced gain and increased distortion in the limiter. The cathodes of the 6AL5 are biased positive with respect to their plates. Thus the tube will not conduct until the output audio signal, fed through the 12AT7, exceeds this bias, or limit level. Control of both this bias and the 6SK7 screens is obtained with the 0D3 voltage-control tube. The adjustable resis-

40% Sharper Tuning

than any other AUTOMATIC ROTOR

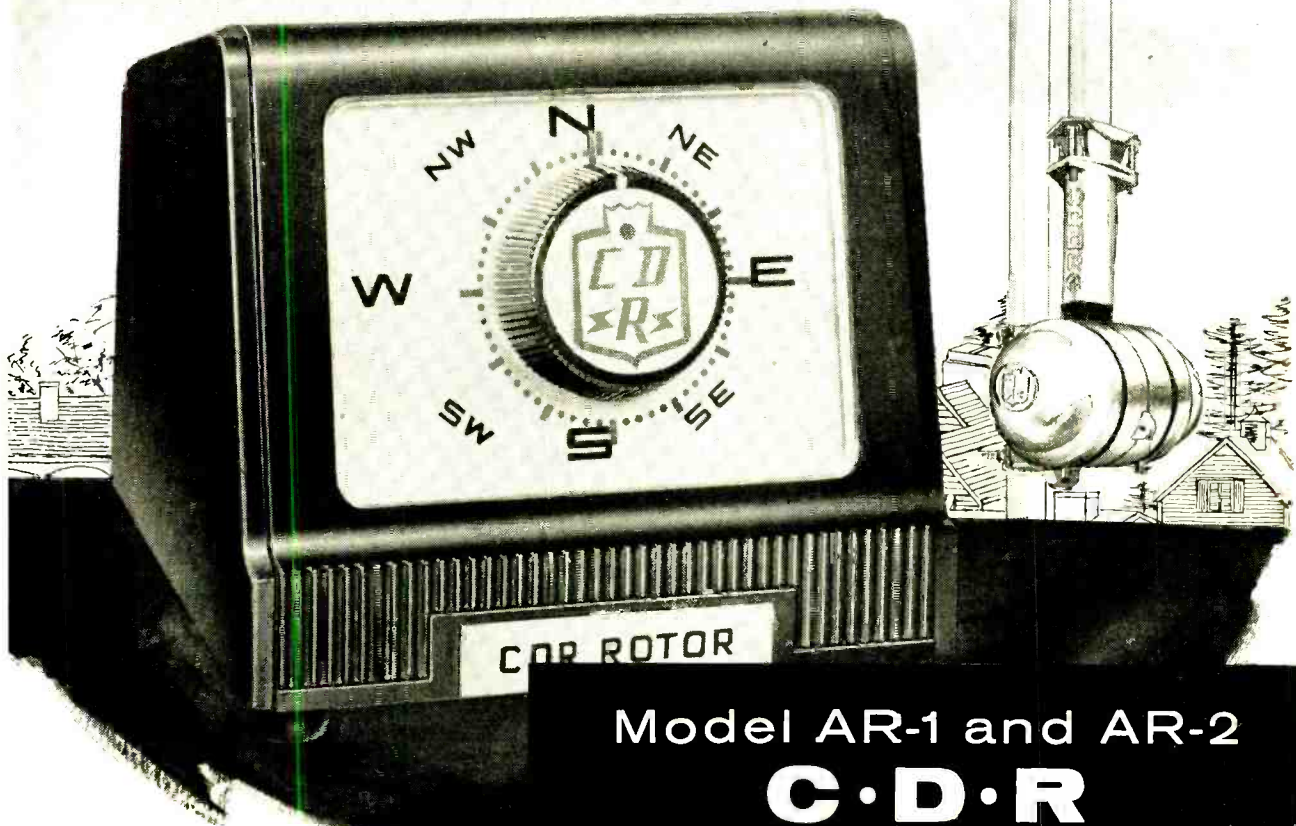

Model AR-1 and AR-2

C·D·R

automatic **ROTOR**

★ Here is EVERYTHING that ANYONE could ask for in a rotor! Powerful enough to turn any TV antenna... sturdy construction... and a handsome modern design plastic cabinet that AUTOMATICALLY turns the antenna to any position... AND ACCURACY that presents 40% SHARPER TUNING than any other automatic rotor!

...AND THEY ARE PRE-SOLD to consumers in every leading rotor market area with saturation TV SPOT ANNOUNCEMENTS!

Model AR-2... complete AUTOMATIC rotor with thrust bearing... and handsome modern design cabinet, uses 4 wire cable

Model AR-1... same as AR-2 without thrust bearing

Field Tested
For Years

*& Tried
& Tested
& Proven*



CORNELL-DUBILIER
SOUTH PLAINFIELD, N. J.



THE RADIART CORP.
CLEVELAND 13, OHIO

WARD Antenna Rama

... means a complete merchandising and profit building program for TV antenna dealers ... antennas designed to meet any installation requirement ... in every price range ... smartly styled ... precision engineered ... and backed by dynamic advertising and merchandising ... all designed to make **WARD** your most profitable line!

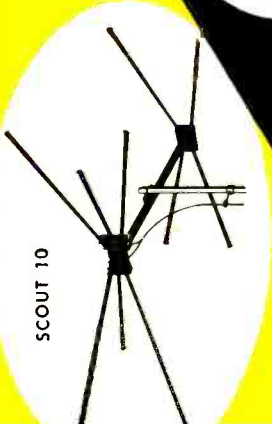

SCOUT 10

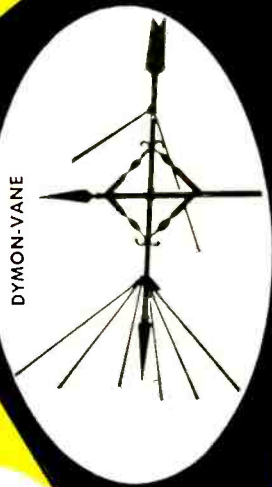

DYMON-VANE

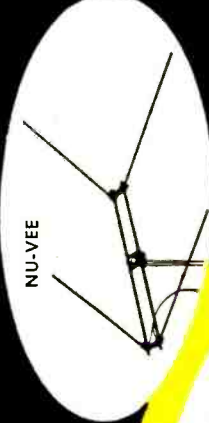

NU-VEE

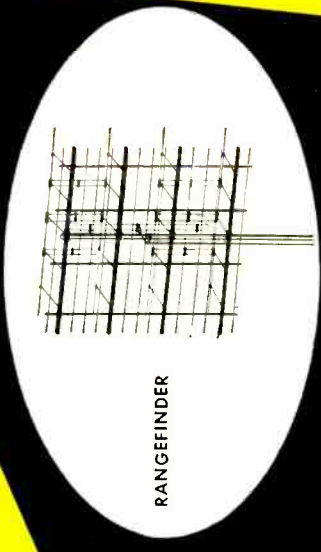

RANGEFINDER

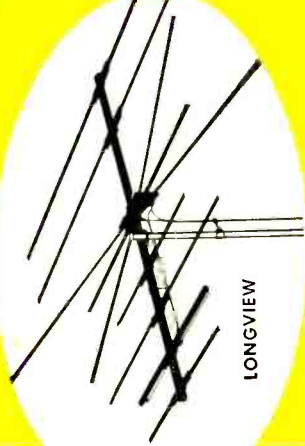

LONGVIEW

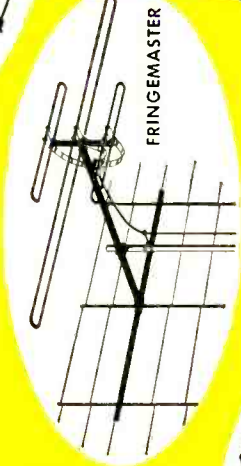

FRINGEMASTER

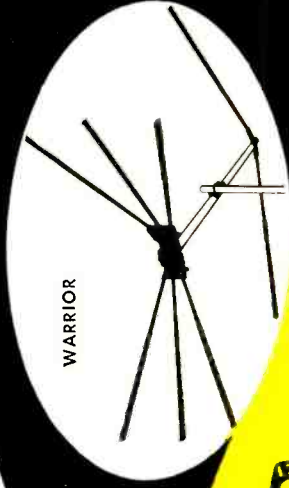

WARRIOR

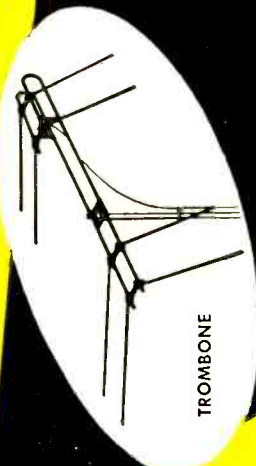

TROMBONE



INSTALLATION KIT



Let SAM work for you...

Sales promotion — Eye catching displays, mailing pieces, catalog sheets.
Advertising — Effective national advertising plus local tie-in.
Merchandising — Quality products, attractive prices, and actual sales leads for you.

WARD PRODUCTS CORP.

1148 EUCLID AVENUE, CLEVELAND 15, OHIO

Canadian Distributor: Atlas-Radio Corp., Ltd., Toronto, Canada

Mr. Serviceman
check these
items for...
Value!



See your local
Parts Jobber



Align-o-Pak

Model BE2

Eliminates TV Alignment Bias Batteries. Provides voltages recommended by all TV manufacturers. Quickly diagnoses AGC trouble.

\$7.85

UHF HI-PASS FILTER



Model HF2

Passes JHF, rejects VHF up to 50 L/B without tuning. Eliminates FM, Airpor, Taxi cab interference, etc.

\$2.37

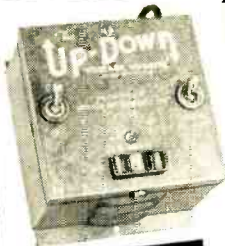

Up-Down
VOLTAGE BOOSTER

Model LB2

Adds or subtracts 10 volts line voltage with heavy, safe toggle switches for any TV set. Line restored to normal when turned off.

\$5.97

PEAK-TO-PEAK Comparison Meter

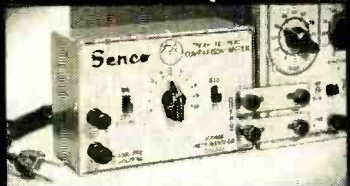

Add peak-to-peak measurements to your scope for only **\$8.75**

Handy for servicing gated AGC, gated sync separator, and essential for color.

Write for Additional Information

SERVICE INSTRUMENTS CO.

422 So. Dearborn—Chicago 5

AUDIO—HIGH FIDELITY

tor on the voltage-control tube allows variation of the limit-level point of the 6AL5. The point at which limiting begins may be quickly determined by connecting a vacuum-tube voltmeter from the control point to ground. This voltage will be constant up to the point where limiting starts, at which time it will increase. In the schematic, the bias

Resistors: 1—390, 1—680, 2—1,000, 1—2,000, 1—2,700, 4—10,000, 1—22,000, 1—24,000, 2—47,000, 3—100,000, 2—120,000, 2—510,000, 2—3.3 megohms, 1/2 watt.

Potentiometers: 1—500, 1—25,000, 1—250,000, 2—500,000.

Capacitors: (Paper) 4—.03 μ f, 1—.05 μ f, 1—.01 μ f, 1—.03 μ f, 400 volts. (Electrolytic) 1—10-20-20 μ f, 350-350-25 volts.

Miscellaneous: 2—6SK7-GT's, 1—12AT7, 1—6AL7-GT, 1—0D3, tubes; 1—low impedance transformer, 50- to 600-ohm primary, 80,000 ohms secondary in two sections (UTC A-12); 1—crystal-to-line transformer, 100,000-ohm primary, 50- to 600-ohm secondary (UTC A-27); 1—3-position switch; 3—4-terminal mounting strips; 1—4 x 3 x 17-inch chassis; tube sockets, hardware, etc.

line is seen brought out to a terminal so that its voltage may be measured. This voltage normally runs about 1.8 under no-limit conditions.

No output attenuator was provided, although one may be added if necessary. Since additional gain will be required

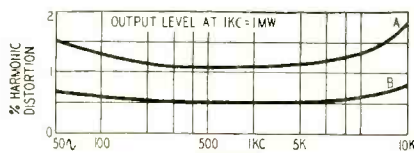

A-15DB LIMITING, B-NO LIMITING

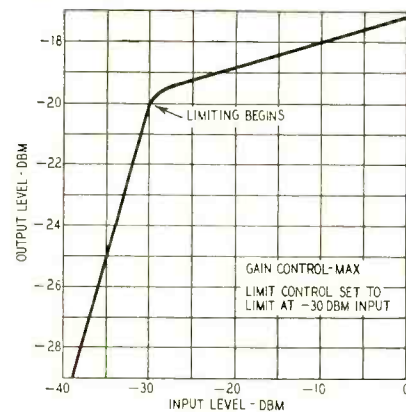

Graphs of limiter performance.

behind the limiter, attenuation control of the output may be obtained at that point. Input-level adjustment should just limit lowest average input level over an average program. Output adjustment is then made as required for the electronic circuits that follow.

The amplifier is built on a full-width standard chassis—4 x 3 x 17 inches. The chassis has wings which permit mounting it on a standard rack. All controls are mounted directly on the chassis.

The limiter amplifier has a number of uses other than for individual user or broadcast station. It can be used with PA or any audio systems where background type of music is required. END

**'SCOPES ARE
"GOLD MINES"**

... when you know how
to use them fully on all
types of service jobs

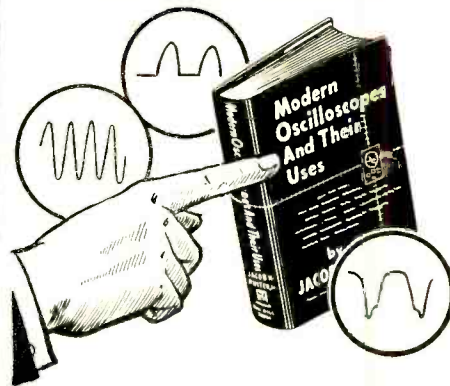

... AND THIS BOOK
MAKES IT EASY TO LEARN
ALL ABOUT THEM!

No question about it! The cathode ray oscilloscope is the handiest, most useful instrument in radio-TV servicing today. Servicemen who master it get the best jobs—make the most money—work lots faster—and are headed for even bigger things in the future!

**MODERN OSCILLOSCOPES
AND THEIR USES**

By Jacob H. Ruiter, Jr.

of Allen B. DuMont Laboratories, Inc.
326 pages. 370 illustrations. \$6.00

- ✓ When, where, why and how to use oscilloscopes
- ✓ How to interpret patterns
- ✓ How to handle tough jobs easier and faster

Now the oscilloscope won't "stump" you—not when you have the clear explanations given by this famous book! It contains no involved mathematics—no puzzling and complicated discussions. Instead, it goes right to work explaining oscilloscopes fully and showing you exactly how to use them in lab work and on AM FM and TV service work—from locating troubles to handling tough realignment jobs. Each operation is carefully explained, including determining where and how to use the scope; making connections, adjusting circuit components, setting the controls and analyzing patterns fast and accurately. About 370 illustrations including dozens of typical pattern photos make things doubly clear.

No other type of specific service method training can mean so much to you in terms of efficiency and greater earning power! Send for it today. See for yourself how this book can help you—before you buy!

READ IT 10 DAYS . . . at our risk!

Dept. RE-104, RINEHART & CO., Inc.
232 Madison Ave., New York 16, N.Y.

SEND MODERN OSCILLOSCOPES AND THEIR USES for 10-DAY EXAMINATION. If I decide to keep the book, I will then remit \$6.00 plus a few cents postage in full payment. If not, I will return book postpaid and owe you nothing.

Name

Address

City, Zone, State.....

Employer's Name & Address.....

OUTSIDE U. S. A.—Price \$6.50 cash only.
Money back in 10 days if book is returned.

By Joseph Marshall

Part VIII—Methods of
checking and measuring
the tracking angle
and needle pressure

THE tracking angle of a cartridge is extremely important from a distortion point of view, particularly with symmetrical cartridges like the G-E, Audak, and piezoelectric cartridges. The ideal motion is one which is exactly at right angles to the faces of the two poles, or the planes of the crystal. However, since the angle of the arm in the groove varies as the needle moves from outside to inside, of the record, this ideal can be met exactly at only one point. The tracking angle is a function of the length of the arm and its curve. The angle of the arm of changers and manual players which come with built-in arms can be presumed to be proper—except when a new type of cartridge has replaced the original one which came with the equipment.

There is no categorical rule on tracking angles. A good rule-of-thumb check is: Place a 12-inch record on the turntable and set the pickup so the needle is about halfway between the outermost and innermost grooves. Now sight along the edge of the cartridge, the needle mount, or the edge of the lever to which the needle is attached. Estimate whether the line formed by this edge is more or less tangential to the curve of the groove. (See Fig. 1.) If it is not tangential, try the same thing on both the innermost and the outermost grooves. If the tracking is tangential or close to it at one of these three points, you can safely assume that the tracking angle is good. However, if the tracking seems to miss the tangent by 10 degrees or more at every point, it would be an excellent idea to check the instructions which come with the arm or changer to see that the arm is properly mounted.

The simplest measure of correct tracking is the so-called overhang of

the needle. Carefully place the cartridge on the center pin or as close to the center as you can. Now observe how far past the center of the hole or pin the needle is. The proper overhang depends on the length of the arm. The length of any arm is the shortest distance from its mounting center to the point of the needle. In curved arms, it will be the bowstring line on the inside of the curve. The following table gives the proper overhangs for arms of various lengths:

Length (inches)	Overhang (inches)
6.5	.64
7	.60
7.5	.56
8	.52
9	.47

Unfortunately the differences are very slight and rather exact equipment is needed for precise measurement. However, the overhang is close to ½

inch. So, you have a rough rule-of-thumb check here—if the overhang is around ½ inch, it is probably O.K.; if less or more, you'd better check manufacturer's instructions before going further.

On changers, a change to a new type of cartridge often changes the tracking angle. This is because the distance from mounting centers to needle center is not standardized; it is likely to be greatest when a crystal pickup has been replaced by a magnetic. Check the overhang, and if much greater or less than ½ inch see if the cartridge can be moved forward or back enough to produce the proper overhang. Unfortunately, this is not always possible. The G-E, for instance, allows no leeway in this respect.

The Pickering comes with a special mount, and the cartridge can be positioned exactly. Incidentally, if you are asked to install a new cartridge, you would do well to check the effect on the tracking angle the new cartridge would produce. If the angle will be badly disturbed, you may be able to use a cartridge which permits adjustment, or one the right size to produce good tracking. But if a new cartridge would disturb the tracking angle, the customer will be better off with the old cartridge (even if it is of inferior quality) because a poor tracking angle will multiply the distortion so severely that over-all performance will be much poorer.

Look before you leap!

Don't jump at conclusions about the tracking angle. Keep in mind that opinions differ. Also, appearances can be very deluding. The Ferranti pickup, for example, will seem at first glance to have a terrible tracking angle. But it happens that the element of the Fer-

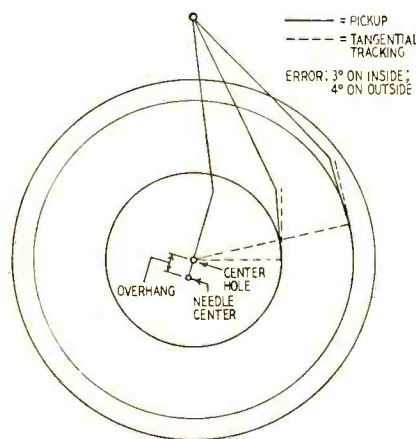

Fig. 1—Tracking of an offset-type arm.

AUDIO—HIGH FIDELITY

ranti is mounted at an offset of 23° to the axis of the arm; so actually the angle is very good indeed.

Needle pressure

There is an optimum pressure for each cartridge, and the manufacturer's recommendations should be followed as closely as possible. Listed below are some of the recommendations (the pressure is given in grams):

Cartridge	Pressure
Clarkstan RV (78 r.p.m.)	20
Clarkstan 204 LP	6-9
Clarkstan 204 (78 r.p.m.)	9-15
Audak (All)	6-9
G-E (78 r.p.m.)	9-16
G-E (33 r.p.m.)	6-8
G-E Triple Play	6-8
Pickering Turnover	4-6
Pickering D-120M (78)	13-16
Pickering D-140S (33)	6-8
Ferranti (fixed in arm) LP	3
Ferranti (fixed in arm) 78	5
Fairchild	4-6
Titone	6-9

Up to a point, the lower the pressure the better; but when the pressure is reduced to where the pickup shows any tendency to skip or to skate, both record and cartridge may be damaged. Many modern arms, even in changers, provide a means for varying needle pressure. I do not suggest reducing pressure below the minimum recommended by the manufacturer.

The only satisfactory way to measure needle pressure is with a gauge specifically designed for the purpose. Several of these are available at modest prices and any service technician who does considerable phonograph servicing should own one.

Always measure pressure at the level the pickup is in when a record is on the table, and be sure the needle is free to move in the cup of the gauge the small distance it will have to move as the scale is depressed. As important as the static pressure is the pressure developed when the needle moves upward or downward. If the arm mass is high or the vertical bearings have too much friction, the pressure with a slight vertical displacement—as when the needle is pinched in a curve of the groove—may change the pressure by as much as 200%.

If it is possible, try moving the gauge upward and downward about 1/8 inch from the reference level and observe the reading. The pressure will increase as the pickup is raised and decrease as it is dropped. The variation should not be more than about 2 grams for an LP cartridge with a normal pressure of 6 to 8 grams. If the variation is greater than this (or more than 25% with other normal pressures) examine the vertical bearings of the arm, adjust, and lubricate. A touch of very light graphite grease or the merest drop of oil is sufficient; too much lubricant attracts and holds dirt and increases friction.

When examining the arm for vertical

Advanced Electronics

Engineers and Physicists

*to conduct classroom
and laboratory educational
programs involving
advanced systems work in
the fields of radar fire
control, electronic computers
and guided missiles.*

Airborne electronics is the field where greatest advancements are being made, because of military emphasis. Developments in these highly active areas call for an increasing number of graduates in Electrical Engineering or Physics, with instruction experience in radar, radar fire control systems, electronic computers, and other military electronic devices and equipment.

At Hughes Research and Development Laboratories in Southern California engineers assigned to this program are members of the Technical Staff. As training engineers they conduct Hughes equipment maintenance and operation instruction within the Laboratories for both military personnel and beginning field engineers.

Prior to assignment, engineers participate in a technical training program to become familiar with latest Hughes equipment. After-hours graduate courses under Company sponsorship are available at nearby universities.

Scientific and Engineering Staff

Hughes

RESEARCH AND
DEVELOPMENT LABORATORIES

Culver City, Los Angeles County, California

Assurance is required that relocation of the applicant will not cause disruption of an urgent military project.

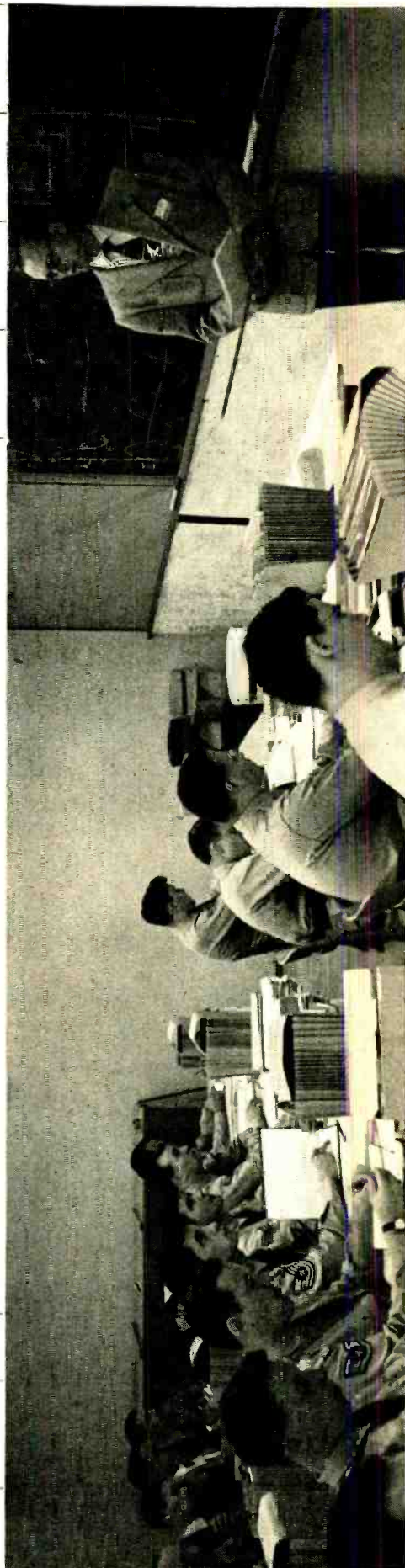

VERSATILE

for
Replacement Use --

78-45-33 1/3 RPM

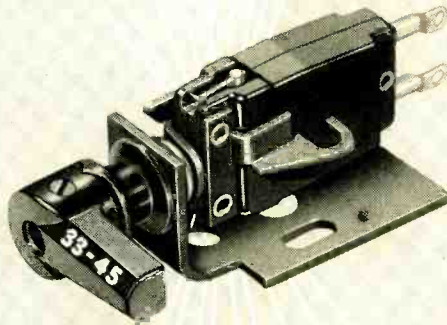

MODEL AX

WEBSTER ELECTRIC
Featheride[®]
CRYSTAL CARTRIDGE
--with twist mechanism

This exceptionally lightweight, two-needle crystal cartridge—MODEL AX, one of the "Famous Featheride Five"—is ideal for fast, easy replacement in literally scores of applications. MODEL AX comes furnished with two needles, removable twist mechanism, terminal lugs and complete installation instructions. It fits any standard RMA 1/2-inch mounting in tone arms with or without twist mechanism.

Write today for full information on the MODEL AX. It will give complete customer satisfaction—and will build sales and profits for you.

SPECIFICATIONS • DATA

TYPE • Two-needle crystal cartridge with twist mechanism
APPLICATION • For 78, 45 and 33 1/3 rpm use
OUTPUT (1,000 CPS) • 1.25 volts at 78 rpm—.85 volts at 33 1/3 or 45 rpm
TRACKING PRESSURE 7 grams (all speeds)
CUTOFF FREQUENCY 5,000 CPS
NET WEIGHT • 13 grams
NEEDLES • One 1-mil osmium, also one 3-mil osmium furnished

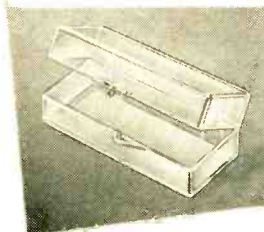

"JEWEL-CASE" PACKAGING

Each MODEL AX cartridge is packed in its own handsome and useful "jewel case" of clear plastic.

WEBSTER ELECTRIC
RACINE WISCONSIN

"Where Quality is a Responsibility and Fair Dealing an Obligation"
WEBSTER ELECTRIC COMPANY, RACINE, WISCONSIN • EST. 1909

AUDIO—HIGH FIDELITY

friction, check also the lateral friction. This is very difficult to measure, and a delicate touch and good judgment are necessary. For LP records the lateral pressure necessary to move the arm across the record should not be much more than 2 grams. The arm should move with the slightest touch and should be perfectly free throughout its whole arc. If it is not, or if the needle has a tendency to lock in a groove, check the lateral bearings. These are usually one or more ball bearings. An extremely light dab of oil usually will set matters right, unless the bearings have rusted or the grease has solidified. In such cases the bearing should be cleaned with penetrating oil or cleaning fluid, possibly dressed with a cloth lightly dabbed with jeweler's rouge, and then repacked with oil or grease, as recommended in the manufacturer's instructions.

Finally, the better and freer the arm and the lower the pressure, the more likely that a significant departure of the table from level will produce skating or locking. A small mason's level, or one of those "string levels," is a most useful tool. Level the turntable in both planes. It can usually be corrected by changing the pressure on the springs used under the mounting holes. In some instances, it may be necessary to level the entire cabinet containing the turntable.

Replacement and repair

Of the commonly used cartridges, the Audak, G-E and Clarkstan permit needle changes by the owner or service technician. The others must be sent to the factory for needle changes. Make no attempt to remove the needle or to make any adjustment on such cartridges. It is recommended that the cartridge be removed from the arm for all needle changes. This makes the change simpler and insures against damage to the arm bearings or the cartridge.

TO BE CONTINUED

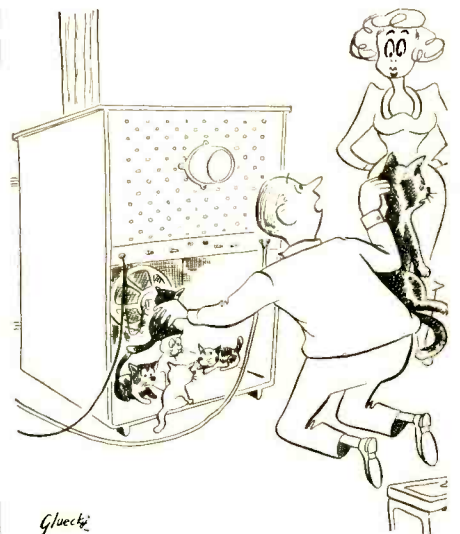

Glueck

"Does this sound like the annoying squeal you've been noting lately?"

New TUBE TESTER

Exclusive

HICKOK

Dynamic
Mutual Conductance



Model 533AP

Larger, easy-to-read meter scale and a calibrated GM circuit provide increased accuracy in testing today's newer tubes.

This handy new HICKOK portable is a sound investment in highest quality electronic test equipment—whether for the radio-TV service bench, the inspection line or the laboratory.

FEATURES . . .

- Exclusive HICKOK Tube Gas Test, Tube Noise Test and Future Tube Life Test provide for accurate electronic circuit balancing.
- New calibrated GM circuit.
- Separate Grid Signal: 2.5 volts AC.
- HICKOK Dynamic Mutual Conductance circuits with most accurate tube evaluation directly in micromhos.
- Bias Fuse prevents accidental damage to bias potentiometer.

Write today for full information on the HICKOK complete line of Dynamic Mutual Conductance Tube Testers.

THE HICKOK ELECTRICAL INSTRUMENT CO.
10531 Dupont Avenue Cleveland 8, Ohio

Technotes



ZENITH J2026R

Symptom: Horizontal phase detector inoperative. Trace the wire from the lead from pin 3 of the Phonevision socket through the two 100,000-ohm resistors and the .001- μ f capacitor to pin 5 (plate) of the 6W4-GT damper socket that is used as a tie-point for this R-C network. The junction point is pin 2 of the 6W4 with the .001- μ f capacitor going to pin 5 to pick up the pulse for the horizontal phase detector. There is enough leakage between pins 2 and 5 of the 6W4 socket to cause as much as 10 volts d.c. to appear on pin 5 of the 6AL5 phase detector. The normal voltage is about 3.

To remedy this trouble and prevent its recurrence, remove the intermediate junctions from the 6W4 socket and carry them to insulated tie-points installed on the chassis for this purpose.

—Wilbur J. Hantz

MOTOROLA AUTO SETS

The hash choke leads are rather long in Motorola auto radios. In time, normal vibration will cause the coil lead to crystallize and break at the end. You can save a lot of call-backs and time lost later on if you correct this whenever a Motorola is on your bench. Cut the leads as short as possible and resolder.—Bruce C. Vaughan, Jr.

HOWL IN HOME-BUILT 630

A kit type 630 chassis was brought in for correction of vertical compression and realignment. During alignment, I noticed that the set had a bad tendency to take off, but, as it stabilized frequently, I assumed that it was due to spurious oscillations. The set seemed normal until it was placed in the cabinet, then I happened to jar it. The howl that came out was ear-shattering. I changed tubes in the audio circuits and tuner without success. I changed the dual volume control, but the howl remained. Just a touch would set it off. Removing the 6BA6 audio i.f. tube stopped the banshee's wail, so I concentrated on that circuit. I checked the transformers, the sockets, and the components, used every trick in the book, but the howl remained.

Finally a bright light gleamed, could it be the i.f. tuning slugs? Yes, it was. A drop of Glyptal cement on all the slug stems of the audio i.f. cans completely eliminated all vestiges of howl. This is a normal factory procedure for many manufacturers, but since this chassis was home-built it did not incorporate the sealing agent.—H. L. Mat-singer

THE American IDEA

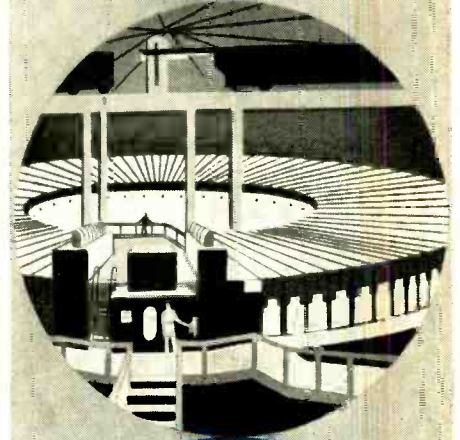

"To find and follow the better way"... Gigantic offspring of the cyclotron, the Bevatron—world's greatest magnet—can send masses of protons hurtling around its 135'-diameter race track at almost the speed of light. "Idea", to penetrate deep into the atomic nucleus, where lie secrets of matter and energy.

With us, the "American Idea" is by directed effort and applied know-how, to continue to lead in bringing you electronic products of the highest quality.



Complete line of
"Full Vision"
Microphones
D-33 Broadcast
D-22 Public Address

Replacement Phonograph
Cartridges

INSIST ON AMERICAN FOR QUALITY
Send for FREE Catalog 47

American microphone co.

370 South Fair Oaks Ave. • Pasadena, 1, Calif.

Convenient to Buy . . . Convenient to Use . . .

LYNN Lightning Solderless Terminals

by **VACO**

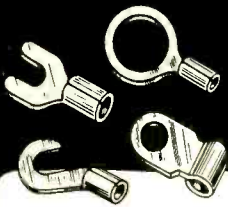

Vari-Board Display

- The clean, modern way to apply terminals to wire
- No soldering necessary
- Choice of all popular numbers in handy \$ Paks
- Plastic service kit contains crimping tool and complete selection of terminals for on-the-job use

3 Ways to Buy Supplies of "Refills"

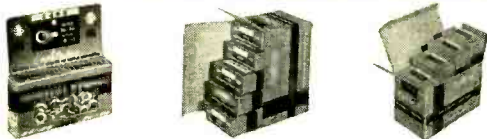

New \$ Pak with life size terminal illustration for easy identification

New "100" Pak contains 100 terminals per box at quantity lot prices

"250" Pak contains 250 terminals per box at volume lot prices

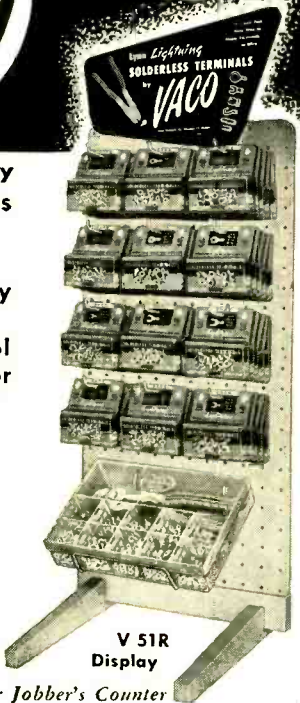

Look for the Convenient Lynn Lightning Display on Your Jobber's Counter

VACO PRODUCTS COMPANY

In Canada: Vaco-Lynn Products Co., Ltd.

317 E. Ontario St.
Chicago 11, Illinois

LEARN

Television-Radio Electricity

REFRIGERATION-ELECTRONICS
IN THE GREAT SHOPS OF **COYNE**

TRAIN QUICKLY! OLDEST, BEST EQUIPPED SCHOOL of ITS KIND in U.S.

Come to the Great Shops of Coyne in Chicago. Get practical training in opportunity fields—TELEVISION-RADIO—ELECTRICITY—ELECTRONICS—visual in Defense Program. Prepare now for a better job in industry or better service rating.

Approved for Veterans

Finance Plan—Enroll now, pay most of tuition later. If you need part-time work to help out with living expenses while at Coyne, we'll help you get it. Special tuition plan for men of Draft Age.

FREE BOOK Clip coupon for Big Free Illustrated Book. No salesman will call. Act NOW.

B. W. Cooke, President
COYNE [SCHOOL]
A TECHNICAL TRADE INSTITUTE CHARTERED NOT FOR PROFIT
Established 1939
500 S. Paulina, Chicago
ELECTRICITY ★ TELEVISION
RADIO ★ REFRIGERATION ★ ELECTRONICS

B. W. COOKE, Pres.
COYNE School
500 S. Paulina St., Chicago 12, Ill. Dept. 74-81H

Send FREE BOOK and full details on:
 TELEVISION-RADIO ELECTRICITY

NAME.....
ADDRESS.....
CITY..... STATE.....

INTERCOM SPECIAL!

STEVE-EL (House of Bargains) HAS DONE IT AGAIN!



Now you can own an intercom that has a thousand uses at a price you would normally pay for a kit.

This intercom comes housed in wooden cabinets completely wired and ready to operate. Outfit consists of one master, one sub station and fifty feet of two wire cable. Ideal for home as baby sitter. Perfect for office or factory. Order now as quantities are limited.



YOUR COST COMPLETE, only **\$15⁹⁵**

FREE BARGAIN CATALOG • WRITE DEPT. RE-10

STEVE-EL Electronics Corp.

61 Reade St. New York 7, N. Y.

TV IN FRINGE AREAS

Philco has a fringe-area switch in some of its TV sets, but most of the models do not come equipped with them. By lowering the a.g.c. voltage, performance can be stepped up in those sets operating in fringe areas. A single-pole, single-throw toggle switch, a 220,000-ohm resistor, and a pin cut from an old octal tube are the parts used in the modification.

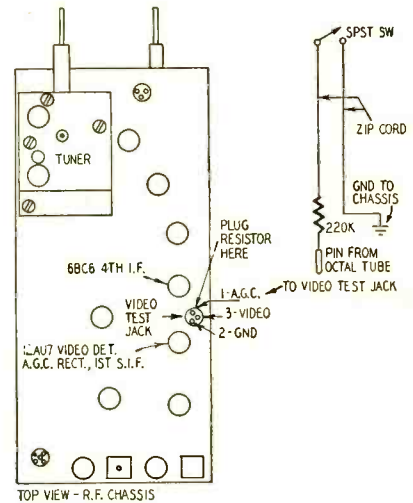

Solder about 18 inches of zip cord to the toggle switch. Drill a hole in the back cover of the TV set and mount the switch. Attach one side of the zip cord to ground and the other side to the resistor as in the wiring diagram. Solder the other end of the resistor in the cutoff tube pin and plug into the front hole of the video test jack on the r.f. chassis. The ideal value of the resistor may differ in your location so it is a good idea to try several of different values.—Bruce C. Vaughan, Jr.

PREVENT FUTURE TROUBLES

When an orphan or off-brand set comes in for service take a few moments to sketch the arrangement of the dial cord; draw the tube layout; record important voltages and the resistance of the oscillator coil. If the tube type numbers are fading, use adhesive tape and indelible pencil or ink to record the numbers on the base. The minutes required to take this data may save hours when the set comes in for repairs in the future.—A. Von Zook

HUM IN RADIOS

Sometimes a puzzling case of hum occurs in amplifiers and radios that have a multisection electrolytic in the power supply and first audio cathode circuits. Common coupling between the capacitor sections transfers some of the power supply ripple voltage to the audio cathode, causing hum in the output circuit.

Capacitor sections that are not usable in cathode bypass circuits because of common coupling can often be used successfully in decoupling circuits if the working voltage is sufficiently high.—R. P. Anderson

END

We Shut Our Order Book!

In spite of frequent increases in plant capacity, we have often had to refuse orders from set manufacturers for Mallory FP Capacitors. If we hadn't, we would not have had enough to meet demands from servicemen all over the country. That's...

*Proof Positive of
Mallory Capacitor Dependability*

Shut your door—

on complaints and loss of time and money that call-backs cause you. Always use Mallory Capacitors on your service jobs.

The Mallory FP Capacitor Line is complete. There is a rating for every set. Mallory FP's are the only Fabricated Plate Capacitors on the replacement market. And they cost no more than ordinary capacitors.

Always order Mallory Plascaps® for your plastic tubular capacitor needs. Improved moisture-proofing puts an end to shorts, and leads are permanently secured.

Prove to yourself— as many manufacturers and thousands of servicemen have—**YOU CAN ALWAYS DEPEND ON MALLORY CAPACITORS.**



P. R. MALLORY & CO. Inc.
MALLORY

CAPACITORS • CONTROLS • VIBRATORS • SWITCHES • RESISTORS
RECTIFIERS • POWER SUPPLIES • FILTERS • MERCURY BATTERIES
APPROVED PRECISION PRODUCTS

P. R. MALLORY & CO. Inc., INDIANAPOLIS 6, INDIANA

Fig. 1—A printed-wiring burnout.

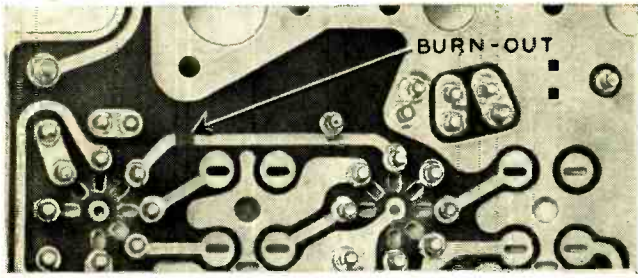

Fig. 2—Measuring leakage with v.t.v.m.

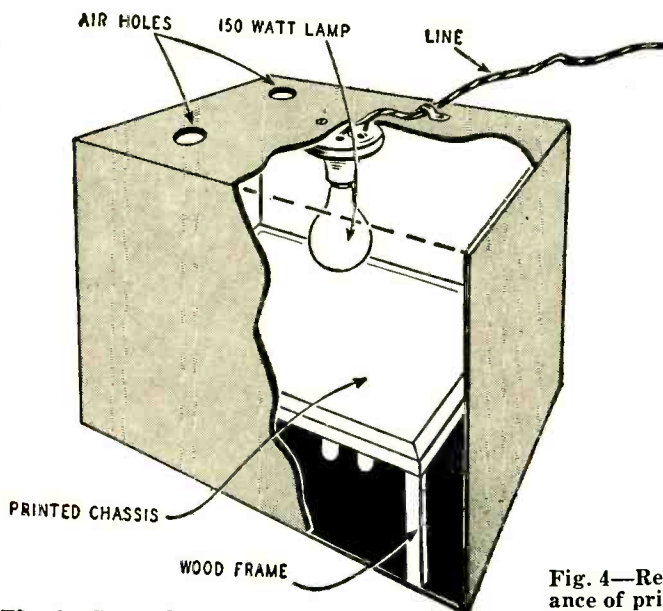

Fig. 3—Setup for finding intermittents.

TECHNIQUES FOR SERVICING PRINTED WIRING

By R. E. RICKETTS*

*Trouble-shooting procedures
are not difficult
in new-type circuit wiring,
but they are different*

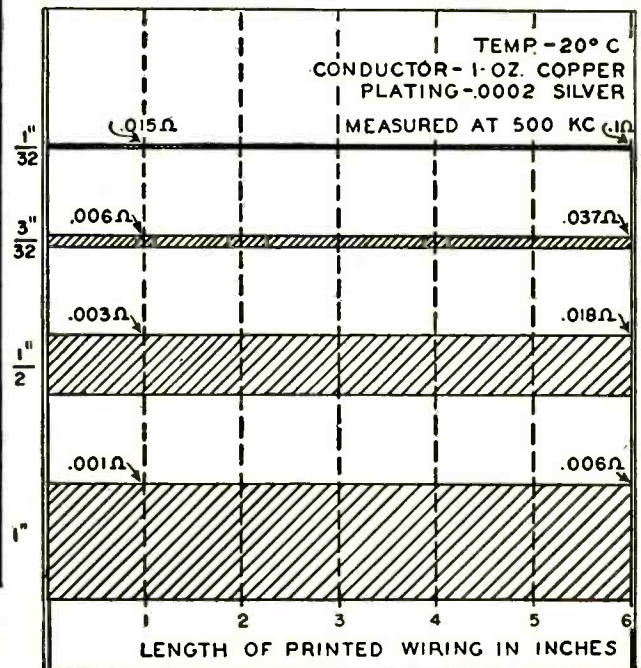

Fig. 4—Resistance of printed wiring.

AT LEAST four major radio manufacturers are producing table-model receivers using the printed-wiring process. Many other companies are adapting printed-wiring techniques to their latest receivers. This adds up to a new branch of servicing that technicians will find both interesting and simple.

Differing mechanically from conventional wiring, *printed wiring* has several characteristic major causes of trouble:

1. Leakage resistance between conductors.
2. Intermittent solder connections or open connections caused by excessive heat.
3. Open printed wiring due to shorted components (burnouts).
4. High-resistance printed-wiring conductors.

Some of these terms may sound new, but most technicians have made similar measurements before; with printed wiring they just have to be made more carefully.

Leakage resistance: At some time in his career every technician has had a burned-out power transformer caused by voltage breakdown across the rectifier tube. Usually this was due to dirt or moisture on the socket which caused a high resistance path. This leakage path became more serious when the power-transformer voltage caused a current flow across this path, which in

turn started carbonization of the phenolic. Eventually a low enough leakage path developed to cause a real short and a burned-out power transformer. The same thing can happen with printed wiring at lower voltages (Fig. 1), only the troubles are not so obvious. However, the repair is usually easier. By drilling a hole in the leakage path, the phenolic is replaced by an air gap as the dielectric material.

You must be able to measure this leakage. A v.t.v.m. such as the RCP 655, sufficiently sensitive to indicate a leakage of 1,000 megohms, should be used. Fig. 2 shows a v.t.v.m. used to measure leakage between an i.f. amplifier plate lead and a ground or shielded area.

Intermittent solder connections: These are nasty things to find, but indications of such a condition are fairly obvious. More than normal heat will usually indicate a true intermittent connection or connections. Put the chassis in a cardboard box with two small air holes at the top, and use a 150-watt lamp as a heat source in the box while the unit is operating (Fig. 3). This additional heat will speed up the opening of the intermittent connection.

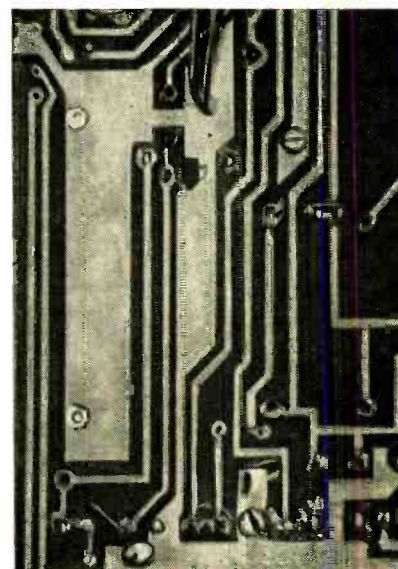

Fig. 5—Chassis has embossed wiring.

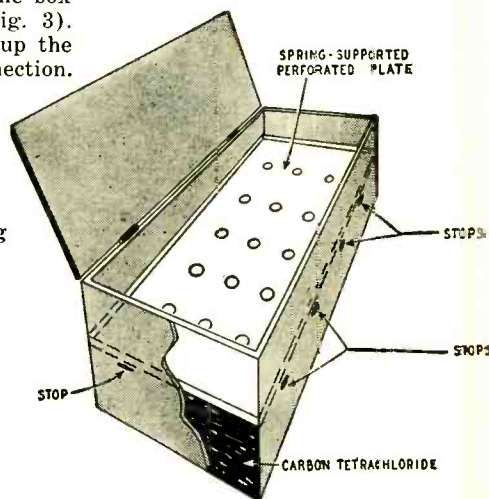

Fig. 6—Printed-wiring cleaning tank.

*Chief Engineer,
Radio City Products Co.

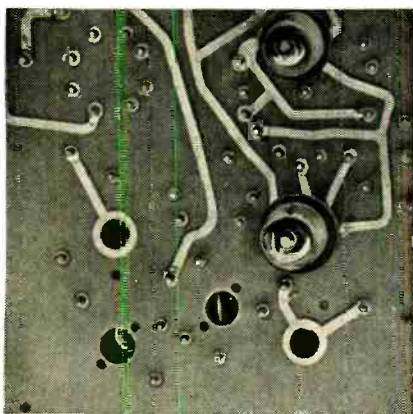

Fig. 7—Portion of high-fidelity amplifier.

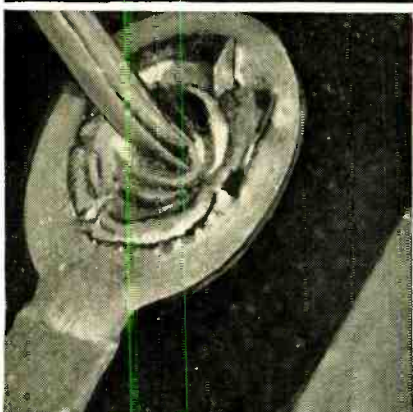

Fig. 8—Dip-soldered pin—enlarged view.

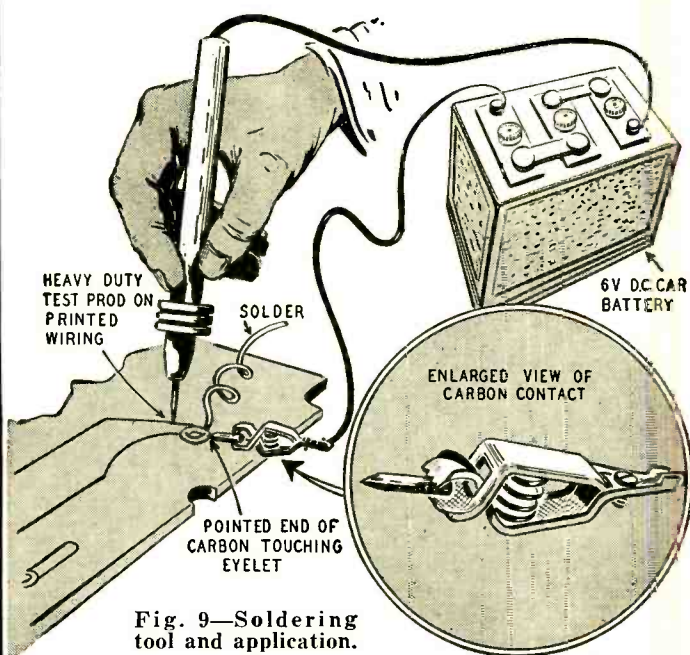

Fig. 9—Soldering tool and application.

Ready NOW!

completely NEW STANCOR TV TRANSFORMER REPLACEMENT GUIDE

The new 1954 Stancor TV Replacement Guide and Catalog is a fully revised, up-to-the-minute listing of accurate transformer replacement data. Every recommendation has been rechecked against the latest information obtainable.

This Stancor reference lists over 6800 TV models and chassis of 115 manufacturers, including hard-to-locate information on "private label" sets.

To make your servicing easier, virtually all flybacks, yokes and power transformers listed are exact replacements. Where an exact replacement unit is not available, reference is made to the circuit or terminal changes required.



FREE
If you haven't received your copy, see your Stancor distributor, or write us directly.

STANCOR-WILLIAMSON ULTRA-LINEAR HI-FI amplifier bulletin 479

Build your own ultra-linear hi-fi amplifier using Stancor high fidelity output transformer A-8072 (\$15.00 net). You can also use A-8072 to convert your present Williamson amplifier to ultra-linear operation. Bulletin 479, available FREE, contains performance curves, schematics, parts lists, chassis layouts and other helpful construction and conversion information.



Stancor transformers are listed in Photofact Folders and Counterfacts.

CHICAGO STANDARD TRANSFORMER CORPORATION
3592 Elston Avenue Chicago 18, Illinois

EXPORT SALES: Roburn Agencies, Inc., 39 Warren Street, New York 7, N. Y.

RADIO

Open printed wiring: Since the wiring can be visually examined, open connections usually can be observed unless components cover up the suspected area. In that case, use a standard ohmmeter to make a continuity test for an open conductor.

High-resistance printed conductors: This term implies a printed conductor that should have a resistance of from 1/10 ohm to 2 ohms but may measure from 6 to 300 ohms, causing low filament voltage or low plate voltage readings. Fig. 4 gives the r.f. resistance per inch of various widths of printed-wiring conductors. High resistance in a printed conductor is easily found by checking voltage readings, taken with a v.t.v.m. at the tube sockets, and comparing them with service notes.

Repairing printed wiring

There are several types of printed circuits. One uses a die-stamped process in which the tubes and a few circuit leads are usually on one side of the chassis or phenolic plate and the major components are on the other. A dull, rough finish on the printed wiring indicates that the circuit leads are hot-tinned or solder-plated.

Use a small pencil iron to replace components on such a unit. There are some chassis of this type in service that have been treated with a resin or wax to improve the surface, or leakage resistance. If a large soldering iron were used to repair this type chassis, the chassis or the printed wiring might be blistered. Excessive heat increases leakage resistance on the printed chassis and can cause the printed wiring to lift from the phenolic base material. Ordinary 60/40 solder can be used for repairs to this chassis.

Fig. 5 shows a chassis with a different type printed wiring. This is silver-conductor or embossed printed wiring. In soldering new components, a very small iron must again be used. Use solder containing some silver. An activated rosin liquid flux may be used, or a pure liquid mixture of rosin and alcohol. This can be purchased from your local drugstore. The ratio is 1 part rosin to 3 parts alcohol. The flux should be stored in a sealed container to prevent evaporation. The original bottle will be adequate if the top is secure and airtight. The silver-embossed chassis can be distinguished from other types by examining a conductor or shield area where there is no solder. If it is a silver-embossed chassis, a gleaming, silvery surface can be seen. Service notes will usually indicate the type printed-wiring chassis with which you are dealing.

Clean working surfaces are helpful in soldering any printed chassis. To assure clean surfaces a simple cleaning tank can be constructed, or you can get the local tinsmith to solder a can as shown in Fig. 6. Put trichloroethylene or carbon tetrachloride in the tank to the level of the dotted lines. This is just below the perforated

Faster, Easier, more PROFITABLE Operation

Get into the MASTER habit!

Brings you the product data of the industry in one handy book—all products vital to your daily sales and service operations. In the customer's home, across the counter or on the bench, you'll value the MASTER'S thoroughly complete descriptions, specs, illustrations and prices . . . all systematically organized in 18 big sections. Over 1300 pages of unabridged catalog data direct from the manufacturers. Keeps you abreast of all latest electronic products. Increase your sales and speed-up your buying—the MASTER way.

As Low As **\$1.95** at your parts distributor. Publisher's price **\$6.50**.

OFFICIAL BUYING GUIDE OF ELECTRONICS-TV-RADIO INDUSTRY

- 1370 pages
 - 8" x 11" — 5 lbs.
 - Over 8,000 illus.
- Just a few of the more than 85,000 items included:

Tubes — Transmitters
Test Equip. — Receivers
Transformers
Capacitors — Antennas
Resistors — Wire & Cable
Coils & Relays
Recording & PA
Hardware & Tools



Eliminates Small Catalogs and Loose Literature

Get your MASTER now from leading parts distributors or write to:
United Catalog Publishers, Inc., 110 Lafayette St., N. Y. 13

HEAR THE DIFFERENCE !

Based on the famous University model WLC Theater System used so successfully and extensively in deluxe stadium and outdoor theater installations . . . auditoriums, expositions, concert halls and other important applications where only the highest quality equipment is acceptable—University engineers now bring you a smaller, compact version—the BLC—for general application in public address work. The BLC is the New standard for both voice and music, indoors and outdoors. The BLC is now yours, at the low low price of

ONLY
\$75
LIST

MAKE *Every* P.A.
A HI-FI INSTALLATION
WITH THE *New* MODEL
BLC

FULL RANGE
WEATHERPROOF
COAXIAL
SPEAKER

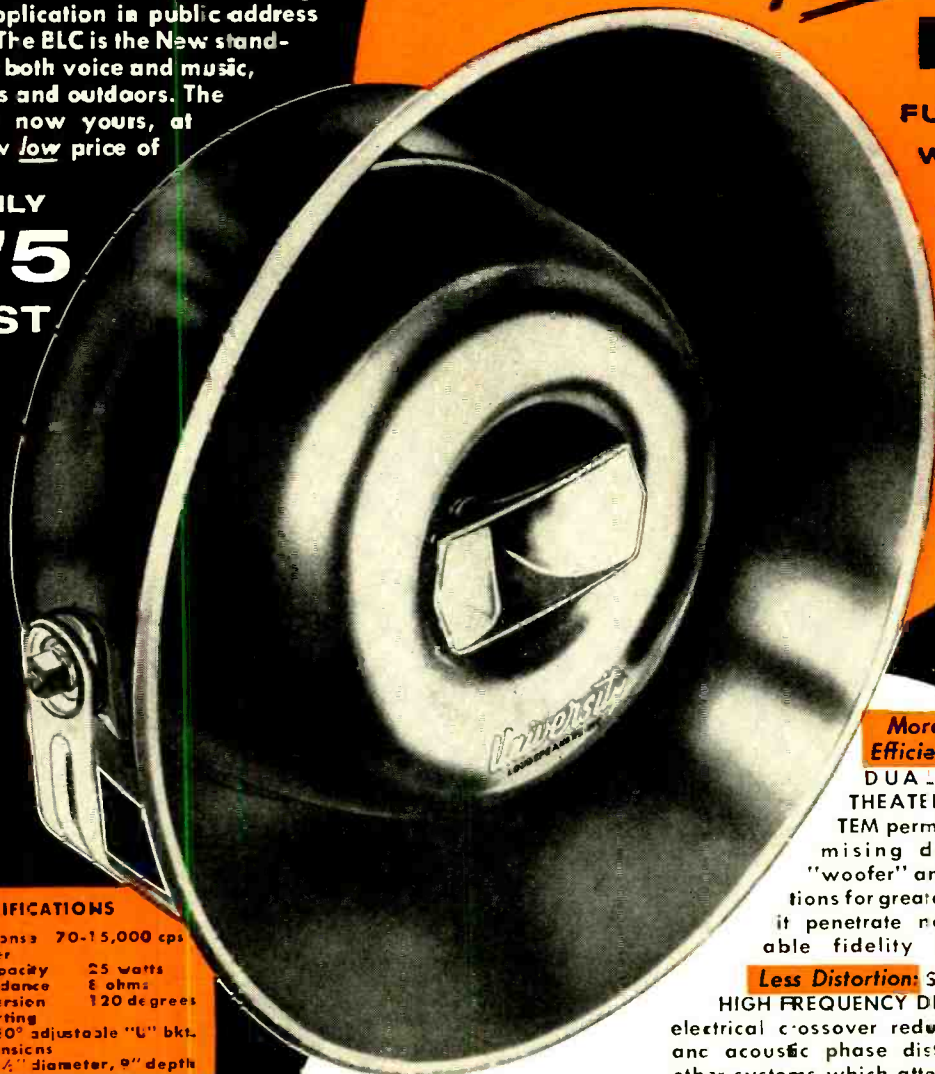

SPECIFICATIONS

Response 70-15,000 cps
Power Capacity 25 watts
Impedance 8 ohms
Dispersion 120 degrees
Mounting 180° adjustable "U" bkt.
Dimensions 22 1/4" diameter, 9" depth

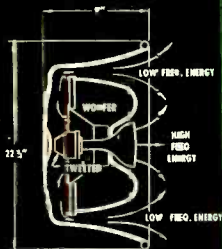

Ask your distributor for a convincing demonstration, and HEAR THE DIFFERENCE!

More Efficient:

DUAL RANGE THEATER TYPE SYSTEM permits uncompromising design of the "woofer" and "tweeter" sections for greatest efficiency. Hear it penetrate noise with remarkable fidelity and intelligibility.

Less Distortion:

SEPARATE LOW AND HIGH FREQUENCY DRIVER SYSTEMS with electrical crossover reduces intermodulation and acoustic phase distortions common to other systems which attempt to use two different horns on a single diaphragm.

More Compact:

EXCLUSIVE WEATHERPROOF DUAL RANGE COAXIAL DESIGN eliminates wasted space. Depth of BLC is only 9"; can be mounted anywhere, even flush with wall or ceiling.

More Dependable:

EXPERIENCED MECHANICAL ENGINEERING AND CAREFUL ELECTRICAL DESIGN meet the challenge of diversified application and environmental hazards. Rugged, and conservatively rated—you can rely on the BLC.

Better Lows: BALANCED "COMPRESSION" TYPE FOLDED HORN, starting with eight inch throat and energized by top quality low frequency "woofer" driver provides more lows than other bulky designs.

Better Highs: DRIVER UNIT TWEETER with exclusive patented "reciprocating flares" wide angle horn transmits more highs with greater uniformity . . . high frequency response that you can hear!

Write Desk No. 5
For Full Descriptive
Literature

University

LOUDSPEAKERS INC.

80 SOUTH KENSICO AVENUE

WHITE PLAINS, N. Y.

ERIE SWITCHES

are sold exclusively through distributors

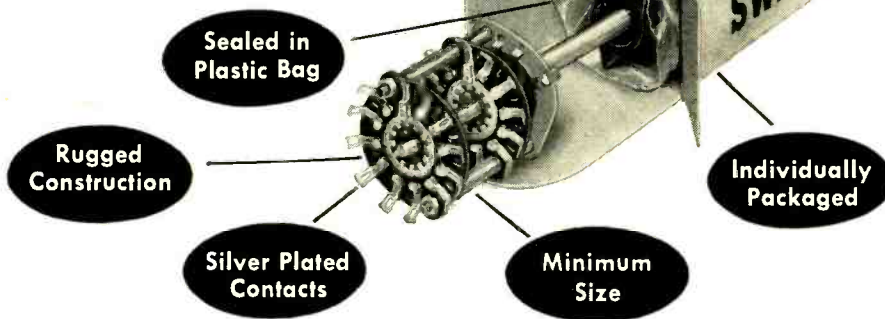

All ERIE Switches have heavily silver plated contacts and high grade phenolic insulators. They meet existing RETMA requirements. The ERIE line consists of 25 items, including shorting and non-shorting types for a wide field of applications in radio, TV, intercommunication, and other electronic equipment.

ERIE Switches are protected in sealed polyethylene bags and individual boxes for preservation and convenient stocking. Each package contains knob and mounting accessories.

Write for complete catalog.

ERIE components are stocked by leading electronic distributors everywhere.

Four Types

- General Purpose
- Single Section
- Multi-Section
- Lever Action

ELECTRONICS DISTRIBUTOR DIVISION
ERIE RESISTOR CORPORATION
Main Offices: ERIE, PA.
Factories: ERIE, PA. • LONDON, ENGLAND • TRENTON, ONTARIO

AUDEL'S TV-RADIO SERVICE LIBRARY

HERE IS LATE INFORMATION IN A HANDY FORM FOR RADIO AND TELEVISION REPAIRMEN, SERVICEMEN AND STUDENTS



2 VOLS. 6 COMPLETE \$ A PAY ONLY 1 MO.

AUDEL'S T.V.-RADIO SERVICE LIBRARY—Highly Endorsed—1001 Facts—Over 1552 Pages—625 Illustrations, Diagrams of Parts. Presents Important Subjects of Modern Radio, Television, Industrial Electronics, F.M., Public Address Systems, Auto, Marine & Aircraft Radio, Phonograph Pick-Ups, etc.

IT PAYS TO KNOW!

The Basic Principles—Construction—Installation—Operation—Repairs—Trouble Shooting. Shows How to get Sharp, Clear T.V. Pictures. Install Aerials—How to Test. Explains Color Systems, Methods of Conversion, Terms, etc. Includes Ultra High Frequency (U.H.F.)—Valuable for Quick Ready Reference & Home Study. Tells How to Solve T.V. & Radio Troubles—Answers Your Questions.

Get this Information for Yourself. 7 DAY TEST—ASK TO SEE IT!

MAIL ORDER

AUDEL, Publishers, 49 W. 23 St., N.Y. 10, N.Y., Mail AUDEL'S T.V. RADIO SERVICE LIBRARY 2 Vols. \$6 on 7 days free trial, if O. K. I will remit \$1. In 7 days and \$1 monthly until \$6 is paid. Otherwise I will return them.

Name _____
Address _____
Occupation _____
Employed by _____ RE

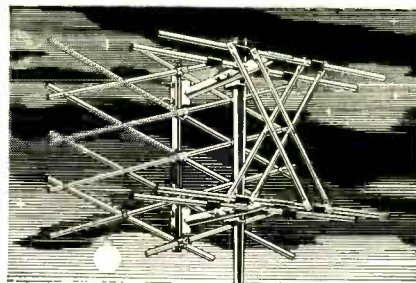

THE NEW RADELCO



ALL-CHANNEL ANTENNA

with the Sensational Diamond-Back Reflector

UNSURPASSED FOR FRINGE AND FAR FRINGE RECEPTION

MODEL DN-2 FOR VHF-UHF
ORDER FROM
YOUR NEAREST **\$34.95** LIST
PARTS DEALER

RADIO

spring-supported plate in the cleaning tank. The chassis to be cleaned is placed on the spring-supported plate, and the plate and chassis are depressed rapidly several times into the liquid. Then permit the chassis to dry. The stop bracket in the cleaning tank will prevent the chassis from going too far into the liquid and avoid coil and capacitor damage. A paint brush and a jar of carbon tetrachloride can also be used for cleaning surfaces to be soldered. Cleaning is particularly important when pins or eyelets are used to hold components. The illustrations so far have been of printed chassis with component leads soldered directly to the printed wiring.

Pin-eyelet printed wiring: Fig. 7 shows a section of a high-fidelity amplifier using pins to support components and to interconnect wiring on two sides of the phenolic card or chassis. Note that the solder has been sweated to the pins.

An enlarged view of a printed wire and soldered pin is shown in Fig. 8. It is at the junction of the pin and the printed wiring that the intermittent connections occur. To assure a permanent solder connection when repairing this type of printed chassis, two basic conditions are necessary—cleanliness, and the proper application of heat and solder.

Cleanliness can be obtained by using the cleaning tank, or a paint brush and carbon tetrachloride. (Caution—allow chassis to dry each time carbon tet is used before applying a hot iron.) Soldering on this type unit requires a special tool. The technician can make such a tool with two heavy wires, two battery clamps, a 6-volt supply, and the center carbon stack from a flashlight cell. Fig. 9 shows the construction and application of this tool. One side of the battery is clamped to the printed-wiring conductor, or contact is made as shown in the figure. The carbon is touched to the pin, and the solder is held to the junction of the pin and the printed wiring.

Open printed wiring: "Burnouts" are the result of a shorted tube socket or mechanical failure. To repair a burnout, tin a piece of copper on both sides with a heavy soldering iron, place the copper across the burnout, and solder by heating the tinned copper.

High-resistance printed wiring: In a few receivers, copper powder is pressed or printed on phenolic, then the chassis is dipped into hot solder. With this type of printed wiring, high-resistance printed wiring can be occasionally found. A good 20,000-ohms-per-volt multimeter, such as the RCP 453C, or a v.t.v.m type ohmmeter can be used to trouble-shoot this ailment. Copper strips can be used to cure the trouble.

In printed-wiring chassis using pins or eyelets, a high-resistance connection due to poor wetting in the dip-soldering process can also be the cause of a high resistance between two points on a conductor. Again the ohmmeter is used to trace the wiring for continuity. END

Your CBS-HYTRON BUSINESS BUILDERS

ARE COMING TOO MANY... TOO FAST... TO ADVERTISE!

It would take a dozen ads to tell you *all* about *all* of them. Because there are so many fine, new CBS-Hytron business builders. And there is so much you'll want to know about every one.

HERE'S JUST A ROUGH IDEA...

- Stationery... modern, color-blended**: Includes forms for "YOUR NAME HERE" and "CQS Repair Sticker".
- CQS Jumbo Illuminated Clock/Sign**: A clock with "RADIO...TELEVISION Certified QUALITY SERVICE" and "CBS TUBES" text.
- CQS Illuminated Outdoor Sign**: A sign for "RADIO...TELEVISION Certified QUALITY SERVICE" with a space for "DEALER NAME".
- Solder Dispenser and Refills**: Includes a "CBS-HYTRON SOLDER DISPENSER" and "40 REFILLS FOR CBS-HYTRON Solder Dispenser".
- Philips head screwdriver blade** and **Hollow-ground standard screwdriver blade**.
- 4-WAY TOOL**: Includes a "1/4-inch hex socket" and a "5/16-inch hex socket".
- CBS-Colortron "205" loading color picture tube**.
- CTS-RATED 6/12/25C4 complete data**.
- Service Cost... with a tailored look**: Includes a "CBS-HYTRON SERVICE COST" card.

AND HERE'S ANOTHER RED-HOT ONE!
New Seventh Edition
CBS-HYTRON Reference Guide for
Miniature Electron Tubes

Bigger, better Seventh Edition of this perennial favorite is now ready! This CBS-Hytron original lists all miniatures to date, regardless of make. Contains: 329 types, 79 new, 134 basing diagrams, 27 new. Twelve packed pages of data you need daily. And it's FREE!

Get your new Miniature Guide, Seventh Edition, and your new Business Builders Catalog, Second Edition, today. From your CBS-Hytron distributor. Or write direct. But act now!



BUT THEY'RE ALL HERE...

NEW BUSINESS BUILDERS CATALOG, Second Edition, gives you the complete, interesting story. A dozen pages loaded with dozens of new and older CBS-Hytron business builders described in detail. Get your free Business Builders Catalog now. Ask your distributor... or write direct.

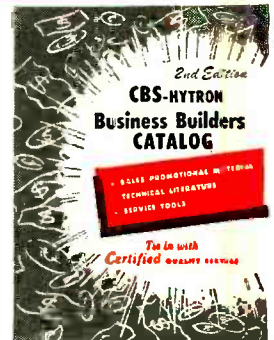

CBS-HYTRON Main Office, Danvers, Mass.

A Division of Columbia Broadcasting System, Inc.

A member of the CBS family: CBS Radio • CBS Television • Columbia Records, Inc. • CBS Laboratories • CBS-Columbia • CBS International • and CBS-Hytron

more on the ceramic capacitor

By JESSE DINES

This amazing component is found in a multitude of sizes and shapes

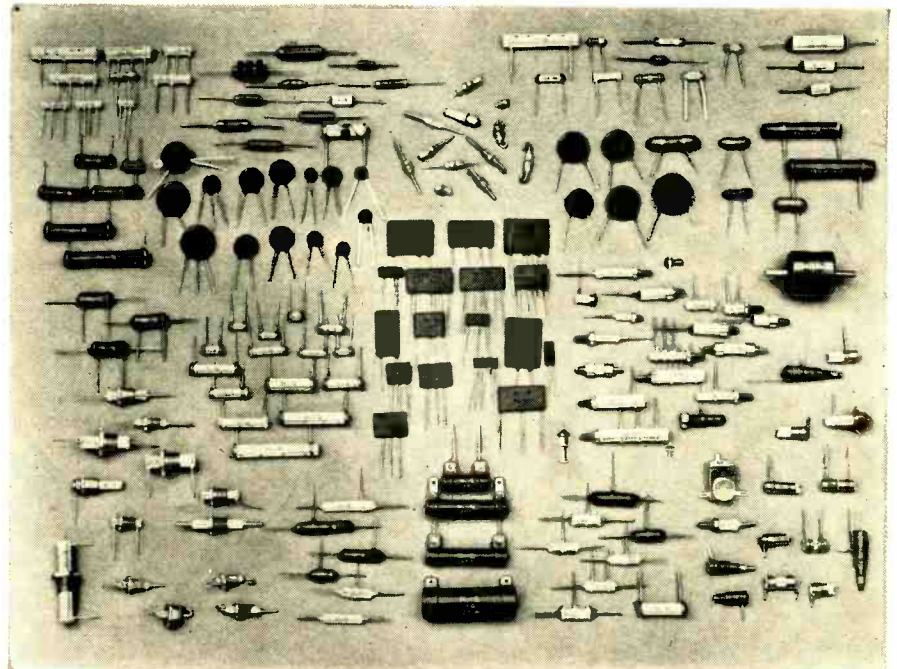
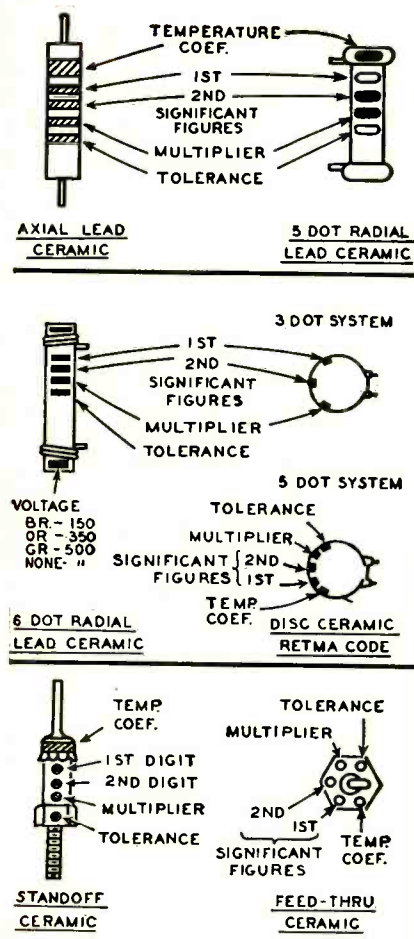

Courtesy Sprague Electric Co.
Fig. 1—JAN and RETMA color codes for various ceramic capacitor types.

Courtesy Aerovox
Fig. 2—Ceramic capacitor types.

CAPACITANCE IN $\mu\mu\text{F}$					
Color	Significant Figure	Decimal Multiplier	Tolerance		Temp. Coeff. PPM/°C.
			C = 10 $\mu\mu\text{f}$ or less	C = more than 10 $\mu\mu\text{f}$	
Black	0	1	$\pm 2.0 \mu\mu\text{f}$	$\pm 20\%$	0
Brown	1	10	$\pm 0.1 \mu\mu\text{f}$	$\pm 1\%$	-30
Red	2	100	—	$\pm 2\%$	-80
Orange	3	1,000	—	$\pm 2.5\%$	-150
Yellow	4	10,000	—	(RETMA)	-220
Green	5	—	$\pm 0.5 \mu\mu\text{f}$	$\pm 5\%$	-330
Blue	6	—	—	—	-470
Violet	7	—	—	—	-750
Gray	8	0.01	$\pm 0.25 \mu\mu\text{f}$	—	+30
White	9	0.1 <	$\pm 1.0 \mu\mu\text{f}$	$\pm 10\%$	+120 to 1-750 (RETMA)*
Gold	—	—	—	—	+500 to 1-330 (JAN)
Silver	—	—	—	—	+100 (JAN) Bypass and Coupling only (RETMA)

*General-purpose capacitors. These have any nominal temperature coefficient within the ranges listed—at the option of the manufacturer.

WE discussed negative and positive temperature coefficients of ceramic capacitors in May, 1954. Now we turn to still another type, the *guaranteed minimum value* (GMV). This term means that the capacitance tolerance is such that the capacitance will not go below its rated value, although within reasonable limits, it may go very high. For example, a capacitor may have a tolerance of 0 to plus 20%, or even 0 to plus 100%. (Possibly tolerances of more than 100% may be found.) GMV's are used primarily in decoupling circuits. Capacitor manufacturers usually only approximate the upper tolerance limits, but attempt to make the lower limit exact.

It is not always easy to determine which types of capacitors can be replaced with others. I consulted many capacitor manufacturers and also relied on practical knowledge to determine the substitutions for various types. These are shown in Table I.

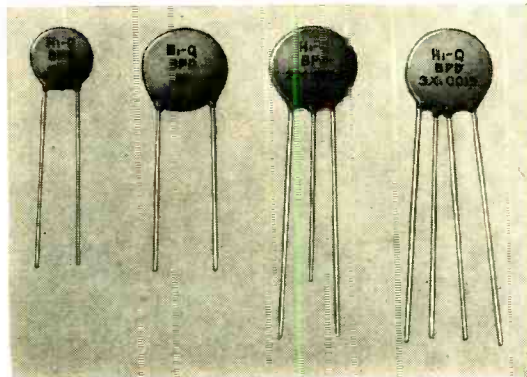
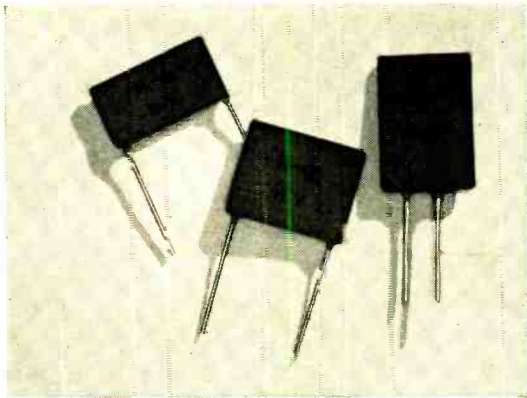

Fig. 3—Plate and disc ceramics.

Courtesy Aerovox

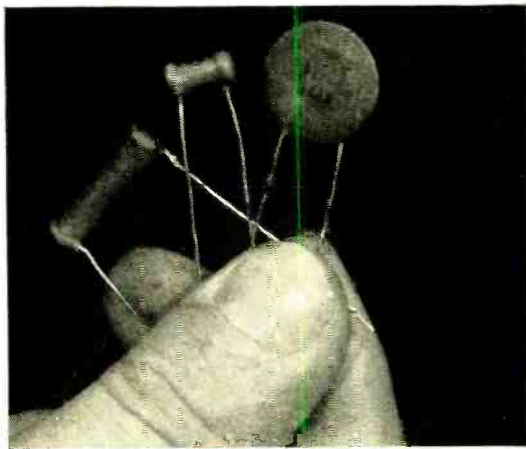

Fig. 4—Disc and tubular capacitors.

Courtesy Aerovox

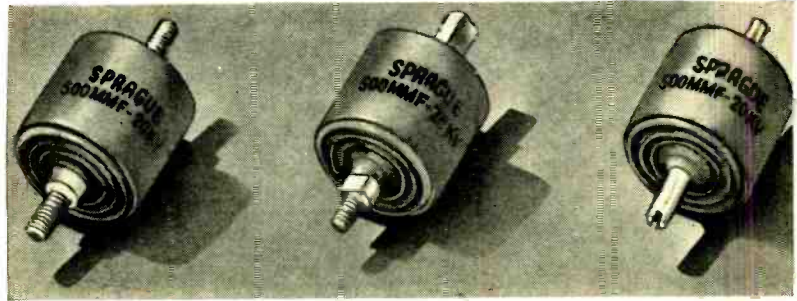

Fig. 5—High-voltage ceramics have various terminal connections.

Courtesy Sprague Electric Co.

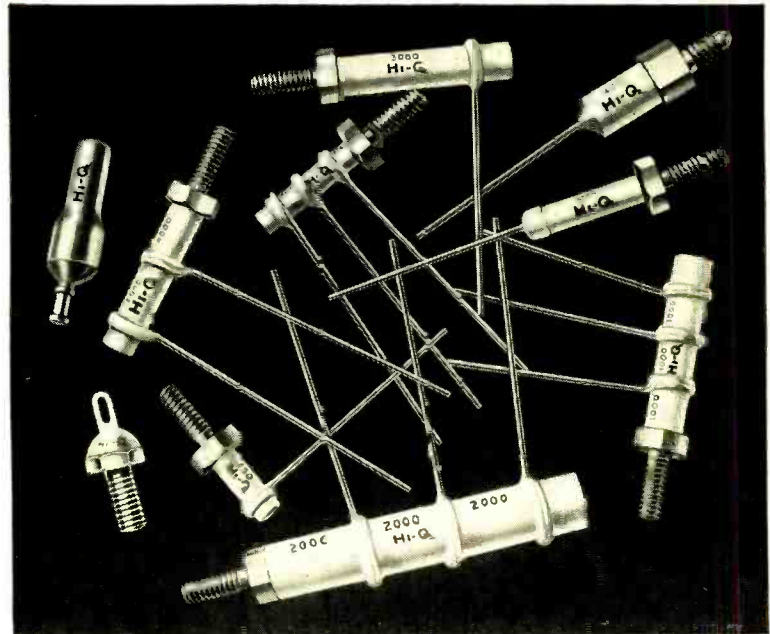

Fig. 6—Various stand-off ceramics.

Courtesy Aerovox

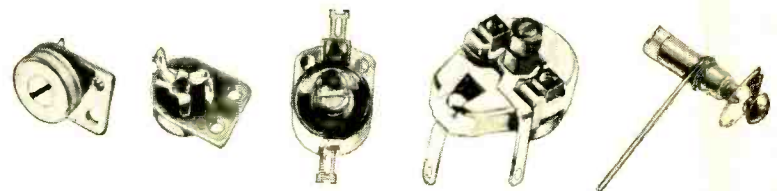

Fig. 7—Ceramic trimmer capacitors.

Courtesy Centralab a division of Globe-Union

Original Capacitor	Can be substituted by:						
	Paper	Mica (general)	Mica (silver)	Ceramic (general)	Ceramic (GMV)	Ceramic (NPO)	Ceramic (NTC)
Paper	Yes	Yes	Yes	Yes	No	Yes	No
Mica (general)	No	Yes	Yes	Yes	No	Yes	No
Mica (silver)	No	No	Yes	No	No	Yes	No
Ceramic (general)	No	Yes	Yes	Yes	No	Yes	No
Ceramic (GMV)	No	No	No*	No*	Yes	Yes	No
Ceramic (NPO)	No	No	No**	No	No	Yes	No
Ceramic (NTC)	No	No	No	No	No	No	Yes***

*Can be used if lowest value of substituted capacitor is not less than GMV.
 Can be used if 1% or 2% tolerance. *Substitute only with exact NTC value.

In certain specific applications some capacitors of course can be replaced with others, though Table I indicates otherwise. For identification purposes, Fig. 1 gives the ceramic capacitor color codes.

Unlike paper and mica capacitors, ceramics are available in numerous forms (Fig. 2) because of their very wide applications.

Plate and disc ceramics: These types (Fig. 3) are recommended where space is a major factor, because of their unusual compactness. Plate and disc ceramics may contain more than one capacitor within the plate or disc, and offer the greatest available capacitance per unit volume. They can be produced in an extremely wide range of capacitances, so are widely used for bypassing and coupling. In these applications

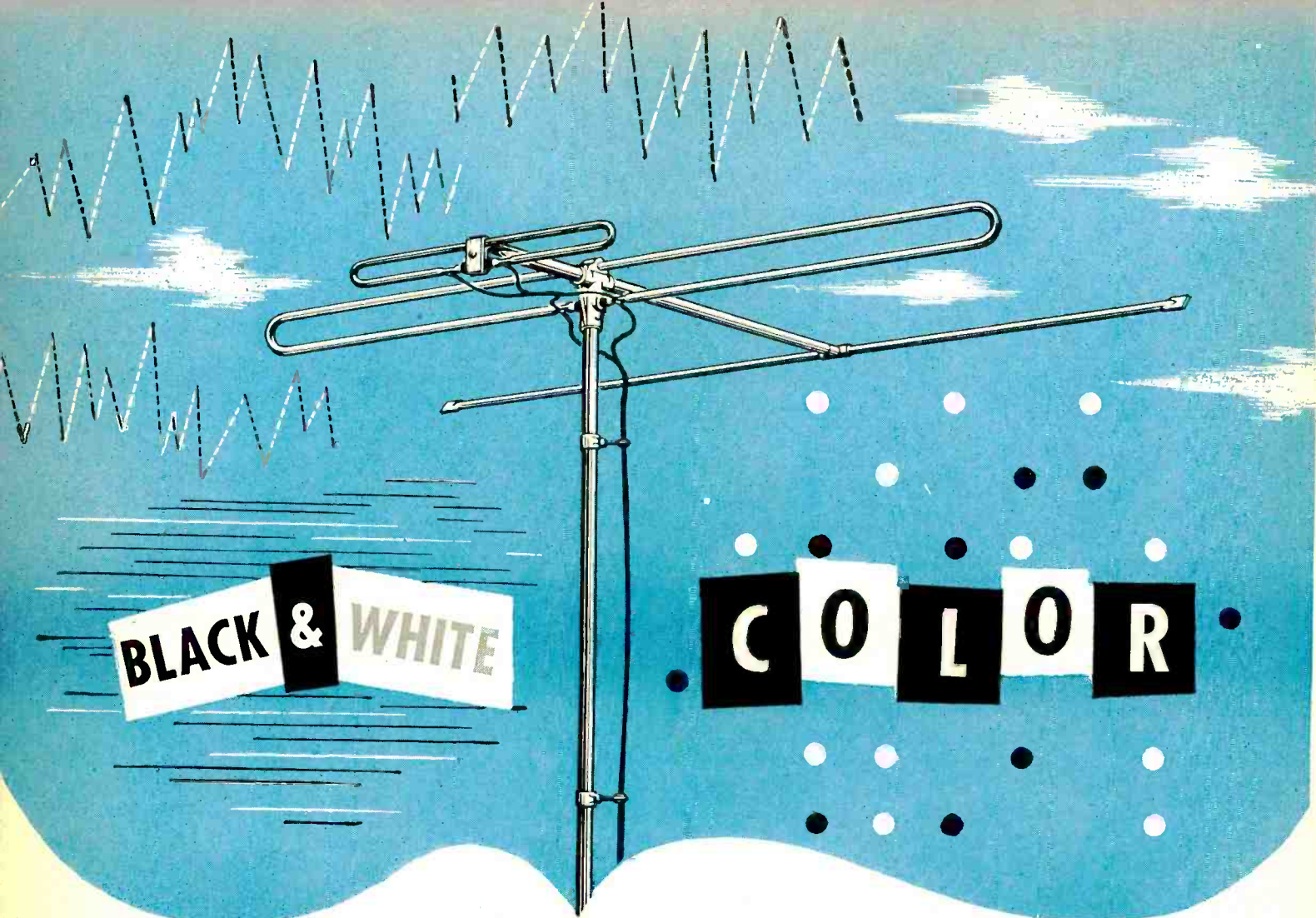

the **INLINE*** is best!

*Reissue U.S. Pat. No. 23,273

Are you overlooking the sales potential of the color-designed AMPHENOL INLINE antenna? Set owners have their color television antenna *right now* if they buy an AMPHENOL INLINE! In terms of present black & white tv set sales, this puts a tremendous sales weapon into every dealer's hands. Their assurance to customers that there will be *no antenna replacement* when they convert to color can be the important inducement to present sales of black & white sets.

facts on Color TV Reception

Fidelity color reception demands these antenna characteristics: flat antenna gain, no gain or loss greater than ± 0.75 db within 1.5 mc below and 0.6 mc above the color sub-carrier. *The INLINE gain is within this requirement over the color band on every channel.* Antenna gain must be held down across the FM frequencies. *The INLINE has been engineered for rejection of FM signals, 88 mc to 108 mc.* Antenna must have a single forward lobe to prevent "scotch plaid" ghosts. *All INLINE directivity patterns reveal a single forward lobe.*

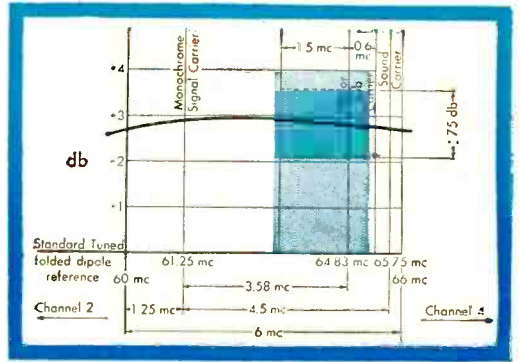

Gain chart showing ± 0.06 db variation over color modulation band for INLINE, Channel 3

Gain variation over the color modulation band for each VHF channel should not exceed ± 0.75 db; the following table gives figures for the INLINE on all channels.

Channel	Gain Variation/db	Channel	Gain Variation/db
2	± 0.40	8	± 0.08
3	± 0.06	9	± 0.04
4	± 0.12	10	± 0.03
5	± 0.27	11	± 0.20
6	± 0.20	12	± 0.30
7	± 0.20	13	± 0.30



AMERICAN PHENOLIC CORPORATION

Chicago 50, Illinois

In Canada: AMPHENOL CANADA LIMITED

many GMV's and NPO's have relatively high capacitance.

Tubulars: The ceramic tubular is fast replacing older-style micas and ordinary paper tubulars in television receivers. Its construction permits operation under any high-temperature condition normally found in television, radio, or automobile receivers. It may be used in any circuit, even as TC's in frequency-determining circuits. Fig. 4 illustrates the size of the tubular and disc ceramic capacitors.

High-voltage ceramics: High-voltage ceramics are commonly used as filter capacitors in high-voltage power supplies for C-R tubes. They are also used as transmitter low-power d.c. filters in mobile, aircraft, marine, and commercial communications equipment, but are not intended for use as TC's or in resonant circuits. When used in television, the terminals are either, or a combination of, plain studs, slotted, tapped internally, or screw type (Fig. 5). When replacing such a capacitor, make sure the terminals are identical to the original ones, to eliminate a mounting problem.

Stand-off ceramics: Stand-off ceramics are basically tubulars, but sometimes may be discs, containing a screw fixture for mounting them at a convenient point on a chassis, such as near a tube socket. A stand-off ceramic may consist of two or three capacitors within the stand-off itself; when this is so, it sometimes can supply all the capacitors necessary for a complete tube circuit. Fig. 6 shows various types of stand-off ceramics.

Trimmers: Trimmers may take various shapes and forms as shown in Fig. 7. They are intended for use where stability is of the utmost importance. Thus, they are used extensively as the variable capacitor in a tuned circuit. Examples of their capacitance ranges are: 0.5-3.0 $\mu\mu\text{f}$, 1.0-6.0 $\mu\mu\text{f}$, 4.0-18 $\mu\mu\text{f}$, 10-110 $\mu\mu\text{f}$. Some are NPO's; others are special NTC's.

Feed-through ceramics—Feed-throughs are a new type of capacitor (Fig. 8) that gives promise of becoming increasingly important. Presently it is

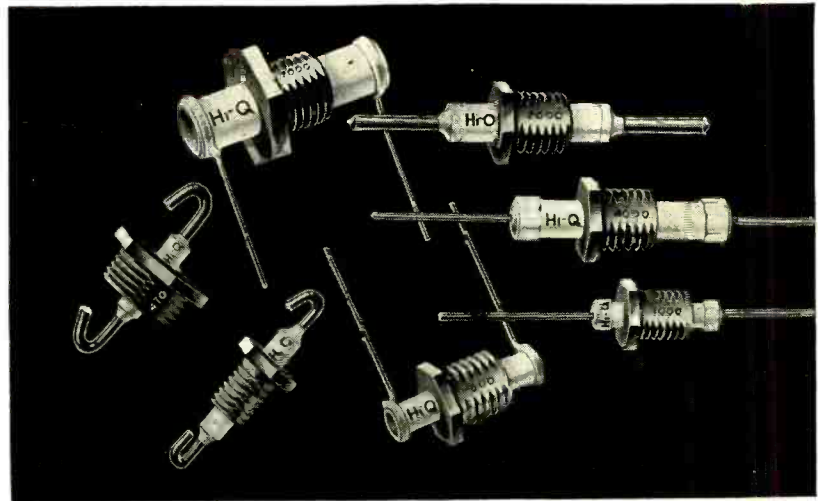

Fig 8—Feed-through capacitors.

Courtesy Aerovox

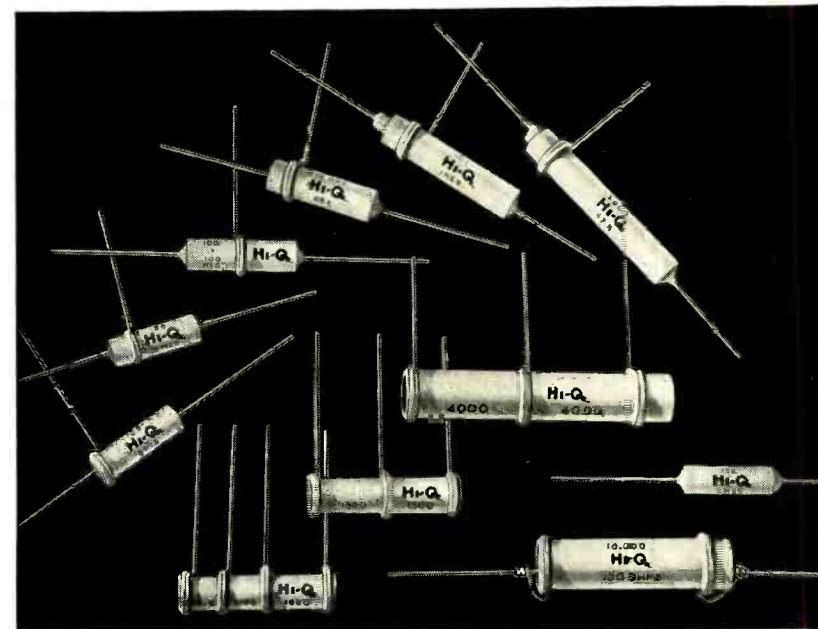
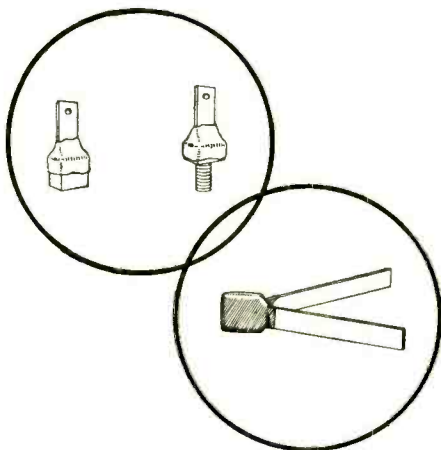

Fig. 9—Resistor-capacitor combinations.

Courtesy Aerovox



Courtesy Mucon

Fig. 10—U.h.f. subminiature capacitors.

**IF
YOU'RE
INTERESTED
IN
HIGH
FIDELITY...
then
YOU'LL WANT
TO KNOW MORE
ABOUT THE
Collaro
High Fidelity
RECORD CHANGER**



Mail This Coupon Today

ROCKBAR CORPORATION, Dpt. MK-18
215 East 37th Street, New York 16, N. Y.

Please send me literature describing COLLARO
High Fidelity RECORD CHANGERS.

NAME.....

ADDRESS.....

CITY.....ZONE.....STATE.....

RADIO

being used in special military electronic gear and some TV equipment. Eyelet feed-throughs are relatively small and are not screw type.

The purpose of feed-throughs is to bypass unwanted signals, and at the same time provide a means of transmission through sections of a chassis or shields that are at ground potential. These units are designed for dependable performance under severe mechanical conditions such as those encountered in aircraft, missiles, and automobiles. In most cases, feed-throughs are manufactured in a wide capacitance range (15 μf to .007 μf).

Ceramics used in transmitters: Ceramics are used in transmitters because they meet the exacting requirements of rigid frequency control. They are used extensively for holding oscillator frequencies to the close limits obtained by crystal control. Such capacitors are usually NTC's.

Hermetically sealed ceramics: These capacitors have been developed for precision circuitry as found in electronic instruments. They are hermetically sealed to withstand the effects of atmospheric moisture. Also, they will withstand vibration and shock normally encountered in military electronic equipment. These capacitors permit capacitance tolerances within $\pm 1\%$ and TC tolerances within ± 10 parts per million per degree Centigrade.

R-C combinations: Mounting small wattage resistors coaxially within ceramic tubular capacitors (Fig. 9) provides a method of combining several circuit components in a very small space. This is useful where either series or parallel R-C combinations are needed; for example, in cathode bias, bypass grid coupling, decoupling networks, and filters.

U.h.f. subminiature ceramics: The Mucon Corporation has developed subminiature ceramics for use in u.h.f. The three types manufactured are shown in Fig. 10. This type of capacitor is used in military equipment such as walkie-talkies and airborne, as well as in commercial equipment such as u.h.f. television tuners and hearing aids.

The two upper capacitors are stand-off .0015- μf 500-volt bypass units. The lower capacitor, a .0015- μf 500-volt unit, has low-inductance ribbon leads.

The higher capacitance values of these units are used in coupling, filter, and bypass applications; lower values are used in tuned circuits and for temperature compensation.

Development of the ceramic capacitor has made possible the design of more stable and sensitive circuits. In turn, development of these circuits has called for still more capacitor refinement. An excellent example of this is in the growth of television, especially in the case of tuners where the feed-through capacitor has largely made possible a stable and sensitive tuner. **END**

FIRST IN ITS CLASS!
JFD ULTRA LOW LOSS

LIGHTNING ARRESTER

The lowest loss of them all For VHF-UHF
Exclusive patented strain relief lips

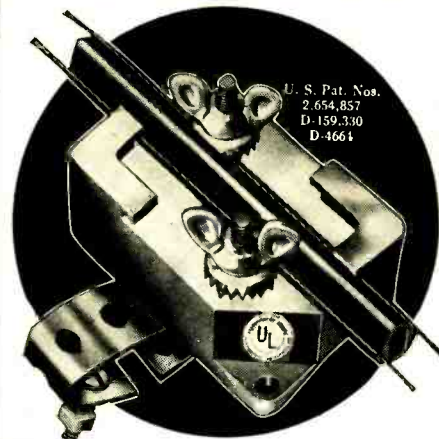

0.5 db. loss at 800 mc. 1.4 VSWR at 800 mc.
For all flat, tubular and open-wire twin lead.

No. **ATH10** (for wall or window sill mounting) **\$1.50** list

No. **ATH10S** (with stainless steel strap for universal mounting) **\$1.75** list

Look to JFD for Engineering Leadership

JFD MFG. CO., Inc., Brooklyn 4, N. Y.
EXPORT DIVISION: 15 MOORE ST., N. Y. C.

TELEVISION

Big demand for graduates

B.S. DEGREE IN 27 MONTHS in radio including TV engineering—VHF, UHF, AM and FM. Students use over \$100,000 worth of equipment including 2 large commercial type transmitters in new TV lab. Intense specialized course includes strong basis in mathematics, science and advanced design in radio and TV. Hundreds of young men each year are earning engineering degrees in this recognized institution. Start any quarter. Many earn a major part of expense in this industrial center. Low tuition. Competent instruction. Thorough, intense, practical program. Also **B.S. DEGREE IN 27 MO.** in Aeronautical, Chemical, Civil, Electrical and Mechanical Engineering. G.I. Gov't approved. Enter Dec., March, June, Sept. Free catalog. **ENROLL NOW.**

INDIANA TECHNICAL COLLEGE
1710 E. Washington Blvd., Fort Wayne 2, Indiana

arkay HI-FI AUDIO kit

10 WATT HIGH-FIDELITY AMPLIFIER

With Built-in Pre-Amplifier for Magnetic Cartridge, Mike, Crystal Phono or Radio Tuner.

- * Frequency response: ± 1 db., 20 to 20,000 cps.
- * Wide response bass and treble controls
- * Speaker output inductance: 4, 8, 16 ohms
- * Negative feedback
- * Hum: 70 db below rated output

Complete with tubes



Model A10 21.95

Write for new catalog of the complete ARKAY line of radio, TV, phonograph and test equipment kits.

arkay
BE 3-6686

RADIO KITS, INC.
120 CEDAR STREET
NEW YORK 6, N.Y.

Watch for the
November Issue of
RADIO ELECTRONICS
on Sale Oct. 26

PROVED BEST

on all weather tests

NEPCO TENNATUBE

STEEL PIPE FOR MASTING

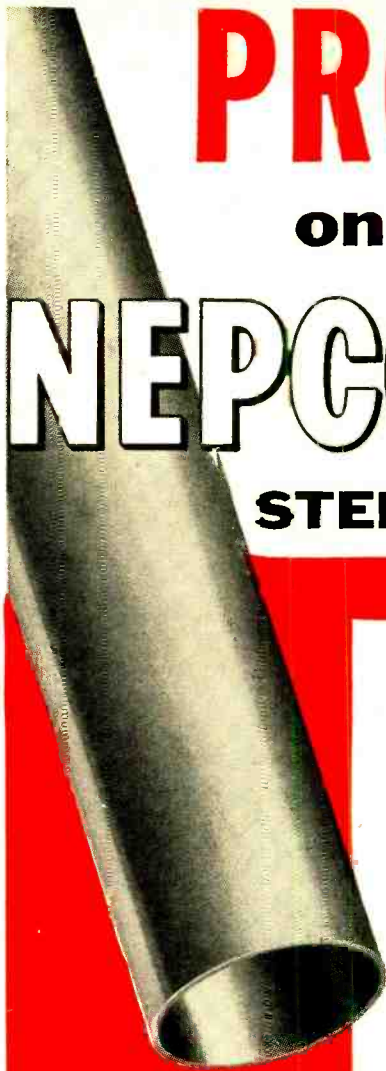

Here's why:



ONLY TENNATUBE HAS ALL THESE FEATURES

- SPECIAL Aluminized Metalescent Finish (inside and out)
- SPECIAL Fosbond* Preparatory Coating (inside and out)
- FULL High-Strength 16 Gauge Steel Pipe (.065" wall)
- FULL 1 1/4" O.D. Steel Pipe
- FULL 6" Expanded End for Superior Strength—Self-Locking Joints

THE FOSBOND PROCESS*

The Fosbond process produces a corrosion-resistant phosphate coating that locks NE's metalescent finish to the steel pipe.

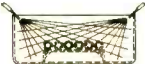
CHECK THE TEST RESULTS

EXPOSURE TEST	NEPCO TENNATUBE	BEST COMPETITIVE MASTING OF THE MANY TESTED
 HUMIDITY TEST 100% Humidity 120° F.	500 Hours NO BREAKDOWN	500 HOURS VERY POOR APPEARANCE
 SALT SPRAY TEST 20% at 95° F.	215 Hours NO CHANGE	215 HOURS VERY PRONOUNCED RUSTING
 WEATHER-OMETER	300 Hours NO CHANGE	300 HOURS BEGINNING TO DETERIORATE

NEPCO LINE INSTALLATION ACCESSORIES

VHF Antennas • UHF Antennas • Wall Brackets • Chimney Mounts •
Banding • Clamps • Guy Rings • Telescoping Masts

National Electric Products

RADIO & TELEVISION DEPARTMENT, PITTSBURGH, PA.

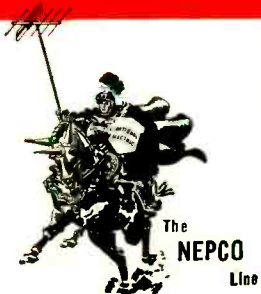

We Are Sharing The Success

YOU helped us build A BIG INVENTORY, we're practically GIVING IT AWAY

EXPORTERS—SCHOOLS—DEALERS—TECHNICIANS, we are selling everything without limit or reserve, some items in thousands, others limited, send your orders in without delay.

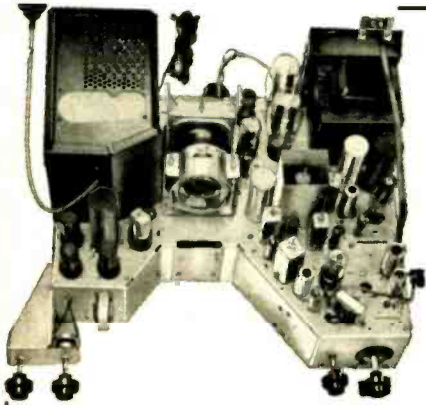

Build your own

#630

Super De Luxe TV CHASSIS

With a #630 SUPER DE LUXE 31-TUBE TV KIT

OPERATES 16" TO 24" PICTURE TUBES • Engineered in strict adherence to the genuine RCA #630 plus added features • **FULL 4MC BANDWIDTH** • **CASCADE TUNER** • **COSINE DEFLECTION YOKE** • **LARGER POWER TRANSFORMER** • **KEYED AGC** • **12" SPEAKER** • **CONDENSERS and RESISTORS** at rated capacities and tolerances. You receive a **COMPLETE SET of PARTS and TUBES**, everything needed is included (less CRT & wire). All I.F. Coils and Transformers are factory pre-aligned and tuned. You will enjoy building it with "LIFE-SIZE easy to follow step-by-step **ASSEMBLING INSTRUCTIONS**" included with each KIT.

was ... ~~\$119.44~~

slashed to

\$99.99

#630 STANDARD TV KIT

Complete Slashed to \$79.41

THIS OFFER MAKES TV HISTORY... never ever so low a price, for such high quality... Quality and improvements in components that will enable the finished chassis to operate 10", 12½" and certain 16" picture tubes... This STANDARD KIT consists of a complete set of parts, similar to those used in the famous RCA #630 29-tube chassis, including all tubes, speaker, resistors in correct 5%, 10%, 20% tolerances, the new Cascade Tuner, etc. and the Brooks LIFE-SIZE Instructions (less CRT & wire)

was \$93.78 slashed to **\$79.41**

Brooks LIFE-SIZE Edition

#630 TV KIT BUILDER SET of INSTRUCTIONS

BUILDING YOUR OWN #630 TV CHASSIS is now simplified with this **COMPLETE SET of BUILDING & WIRING INSTRUCTIONS.**

Covers all #630's, from the RCA 10" SET to the latest SUPER DE LUXE 31-tube 16" to 24" RECEIVER. **EVERYTHING AT A GLANCE—LAYOUT CHARTS** show chassis and components in actual LIFE-SIZE with instructions alongside the illustrations.

INDISPENSABLE for BUILDING, CONVERTING or TROUBLE SHOOTING any #630 TV SET.

was \$2.49 slashed to **\$1.25** postpaid

- HINTS FOR BETTER PICTURES ON 630TV
- 630TV DIAGRAM WITH MODIFICATIONS
- ILLUSTRATED TV CONVERSION MANUAL
- PULSE KEYED AGC CIRCUIT DIAGRAM
- RMA RESISTOR & MICA CODE CHARTS

was \$1.00 Slashed to **50¢** postpaid

THE NEW CASCADE TUNER

can now be installed in ANY TV set
"Brooks CASCADE MANUAL"
with easy to follow step-by-step instructions

was 50¢ slashed to **25¢** postpaid

Send 20% of deposit with order, balance on delivery F.O.B.

BROOKS RADIO & TV CORP.

RADIO-ELECTRONICS

Of Our Products With YOU

as a **CUSTOMER'S DIVIDEND** in the most **SENSATIONAL PRICE SLASHING EVER!**

THE #630 TV RECEIVER remains unmatched for quality and performance • • • RCA designed and developed this set quality-wise *not* price-wise • • • The original 10" set retailed at \$375.00 • • • Subsequent TV sets serve to prove the sacrifice of quality for price • • • what better proof can there be of its superiority than the fact that it is the choice of TV engineers and TV technicians! Herewith we offer you—**YOUR BEST BUYS IN TV!**—All you pay is the price shown • • • Excise taxes have already been paid by us. Names and numbers of manufacturers withheld due to price cuts. Catalogs mailed on request. **NOW you can own a #630 RECEIVER for less than an ordinary TV SET.**

#630 SUPER DELUXE TV CHASSIS

Licensed under RCA patents

COMPLETE READY TO PLUG IN AND PLAY—Similar in characteristics and features to the TV KIT at left • Manufactured especially for us by Nationally Known Manufacturer • No efforts or expense have been spared in workmanship or materials, to make this #630 SUPER DELUXE TV CHASSIS the Best obtainable for fringe areas, clarity and all-around performance. Customers report reception better than 200 miles. Each Set is factory aligned and air-tested • All parts carry the RMA three month guarantee • Our mass volume of business on this CHASSIS (numbering thousands of pleased customers) now makes it possible for us to reduce the price to.....

was \$157.97 (less CRT) slashed to **\$142.27**

#630 TV SPECIALS ^B Nationally Known ^Y Manufacturer

Licensed under RCA patents

THE LEADER—MODEL #1 for giant screen TV Performance 90° deflection, operates all 24" or 27" rectangular and 30" round picture tubes. The last word in TV achievement • Ideal for wall or custom-cabinet mounting • Detailed technical data mailed on request, however with the knowledge that this CHASSIS is a 30-tube #630 with both the Factory's and OUR guarantee, you need not hesitate sending your order in now.

was \$262.50 (less CRT) slashed to **236.25**

COMPLETE LINE OF #630's, SAME MFR.

	UHF/VHF	VHF
MODEL #2 For picture tubes up to 24". Audio connection for use of external amplifier.	was \$249.50	\$139.50
	slashed to \$224.55	\$170.55
MODEL #3 Same as #2, but with True Fidelity Push-Pull audio amplifier.	was \$259.59	\$139.50
	slashed to \$234.55	\$179.55
MODEL #1 For new 90° kinescopes. (24" rectangular, 27" and 30").	was \$299.50	\$262.50
	slashed to \$269.55	\$236.25
MODEL #4 Similar to #2, with modification including area control switch and cadmium plated finish instead of nickel.	was \$224.95	\$179.50
	slashed to \$202.46	\$161.55
MODEL #5 Designed for the utmost in Quality at an Economical price.	was \$209.95	\$149.50
	slashed to \$188.96	\$134.55

(All complete, ready to plug in, CRT not included)



A \$24.95 RADIO for \$6.99

SUPERHETRODYNE RADIO

550 to 1600kc

that fits into a #630 CHASSIS or can be wired into any TV SET, PHONOGRAPH or AMPLIFIER, complete ready to install with tubes and instructions in factory sealed cartons.

slashed to **\$6.99**

NATIONALLY KNOWN BRAND GUARANTEED PICTURE TUBE

MOST desirable 5 sizes—ALL RECTANGULAR • • • BRAND NEW in Factory Sealed Cartons—With a Full Year Guarantee

17" #17BP4A was \$29.63 slashed to \$26.66	20" #20CP1B Aluminized was \$39.74 slashed to \$35.76	21" #21EP4B Aluminized was \$44.68 slashed to \$39.21	24" #24CP4A Aluminized was \$66.24 slashed to \$59.99	27" #27EP1A Aluminized was \$82.57 slashed to \$74.31
--	---	---	---	---

CUSTOM-BUILT CABINETS FOR #630 AND ALL OTHER TV SETS—from FACTORY to YOU

5 LEADING STYLES in genuine mahogany or walnut (blond 10% extra) • Ready drilled for any #630 TV chassis and cutout for any 16", 17", 19", 20" or 21" picture tube at no extras in price • Also supplied with undrilled knob panel for any other TV set • **EVERYTHING NECESSARY** for an easy perfect assembly is included • Each cabinet is delivered complete as pictured with mask, safety glass, mounting brackets, backboard, backcup, hardware and assembling instructions • Each cabinet is shipped in an air cushioned carton from **FACTORY to YOU!**

The VOGUE
Most Popular
Table Model

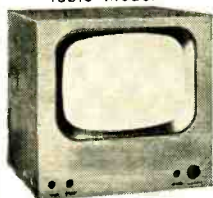

H-25", W-26", D-22"

was \$39.89

slashed to **\$35.91**

The MANHATTAN
Style, Quality, Price



H-41", W-25", D-23"

was \$59.37

slashed to **\$53.43**

The FUTURAMIC
Latest sensation in styling
with tambour roll-in doors



H-37", W-28", D-24 1/4"

Underneath mounting for 12" speaker

slashed to **\$79.34**

Also available with inter-fiber stripped for use with HI-FI equipment
slashed to **\$69.57**

The MAYFAIR
Exquisitely modern, with an elegance of simplicity in styling.

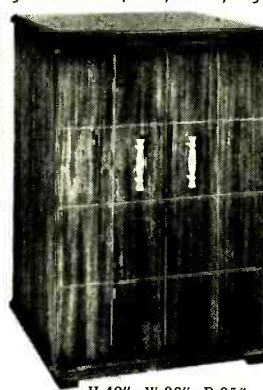

H-40", W-26", D-25"

was \$98.56

slashed to **\$88.70**

The TOWN & COUNTRY
Patterned after the popular credenza. Available for all size picture tubes.

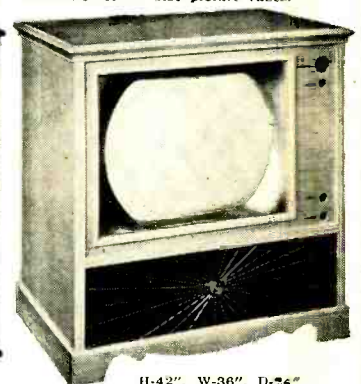

H-42", W-36", D-24"

For 16", 17", 19", 20", 21", 24" or 27" C.R.T.'s was \$109.62

slashed to **\$98.65**

84 Vesey St., Dept. A, New York 7, N. Y.

Wire, Air Mail or Phone Orders for fast delivery. Cortland 7-2359

This SALE is RED HOT—We're Bustin' Prices Wide Open!

Stock up now on these top quality #630 and other TV PARTS for Kit Building, Replacements, Experimenting and for numerous uses on many other makes of TV SETS and Equipment

COMPLETE PARTS LISTING FOR ALL #630 TV SETS

Comprises set of parts for the original #630 STANDARD or the SUPER DELUXE. Parentheses indicate amounts of parts needed in lots of two or over.

	Was	Slashed to
STANDARD CASCODE TUNER, incl. tubes	\$22.49	\$17.97
ESCUTCHEON PLATE, for tuner	.69	.38
COMPLETE SET OF KNOBS, incl. decals	1.34	.99
POWER TRANSFORMER, 255ma.	201T6	9.97
VERTICAL OUTPUT TRANS.	204T2	2.69
VERTICAL BLOCKING TRANS.	208T2	1.32
HORIZONTAL OUTPUT TRANS.	211T1	2.47
HORIZONTAL OUTPUT TRANS.	211T5	3.98
FOCUS COIL, 217 ohms.	202D1	2.29
FOCUS COIL, 470 ohms.	202D2	3.42
DEFLECTION YOKE, cosine 70°	201D1	2.97
DEFLECTION YOKE, cosine 70°	206D1	3.98
SOUND DISCRIMINATOR TRANS.	203K1	1.12
1st PIX I.F. TRANSFORMER.	202K2	1.08
2nd PIX I.F. TRANSFORMER.	202K3	1.08
1st & 2nd SOUND I.F. TRANS.(2)	201K1 ea.	1.02
HORIZONTAL DISCRIM. TRANS.	208T8	1.49
FILTER CHOKE, 62 ohms	206K1	1.47
CATHODE TRAP COIL, keyed AGC	202K4	1.12
WIDTH CONTROL COIL, keyed AGC	201R3	.39
HORIZONTAL LINEARITY COIL.	202L1 ea.	.39
3rd & 4th PIX COILS. (2)	204L1 ea.	.09
FILAMENT CHOKES, (5)	204L1 ea.	.06
VIDEO PEAKING COIL.	203L1	.18
VIDEO PEAKING COIL.	203L2	.18
VIDEO PEAKING COILS. (2)	205L1 ea.	.18
VIDEO PEAKING COILS. (2)	205L2 ea.	.18
ION TRAP BEAM BENDER, double	203D3	.98
ION TRAP BEAM BENDER, single	203D1	.79

VARIABLE CONTROLS

	Was	Slashed to
PICTURE & SOUND, 10k ohms 1 meg. & sw.	1.14	.96
VERTICAL & HORIZ. 50k ohms 1 meg.	1.04	.69
BRIGHTNESS CONTROL, 50k ohms	.44	.36
HORIZ. CENTERING, wirewound, 20 ohms	.57	.39
HEIGHT CONTROL, 2.5 megohms	.48	.38
VERTICAL LINEARITY, 5000 ohms	.44	.36
VERTICAL CENTERING, wirewound, 20 ohms	.96	.69
FOCUS CONTROL, wirebound, 1500 ohms	.98	.69
HORIZONTAL DRIVE, 20k ohms	.44	.12

ELECTROLYTIC CONDENSERS—85° C

	Was	Slashed to
40/10/80 mfd — 450/450/150 v	1.37	.98
40/40/10 mfd. — 450/150/150 v	1.49	.98
80/50 mfd — 450/150 v	1.49	.69
40/10/10 mfd. — 450/150/350 v.	1.37	.69
20/80 mfd — 450/350 v	1.49	.98
250/1000 mfd — 10/6 v	.98	.49

CONVERT ANY TV TO A 16" to 24" RECEIVER

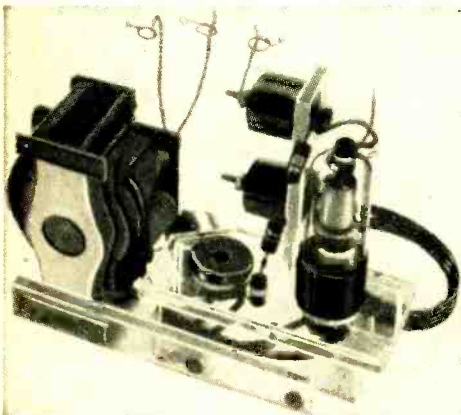

ASSEMBLED KIT FOR THE 630 CHASSIS

Complete as pictured with other parts

was \$15.98 slashed to **\$12.17**

UNASSEMBLED KIT FOR ANY TV CHASSIS

was \$13.98 SLASHED TO **\$11.97**

ILLUSTRATED CONVERSION MANUAL SUPPLIED WITH EACH KIT

BROOKS RADIO & TV CORP., 84 Vesey St., Dept. A, New York 7, N. Y. TELEPHONE COriand 7-2359

#630 TV BASIC PARTS KITS

PUNCHED & DRILLED CHASSIS PAN BRACKET & SHIELD KIT (18 items)
VIDEO & I.F. KIT (19 items)
POWER TRANSFORMER #201T6
VERTICAL OUTPUT TRANSFORMER
VERTICAL BLOCKING TRANSFORMER
FLYBACK TRANSFORMER #211T5
FOCUS COIL, 470 ohms #202D2
COSINE DEFLECTION YOKE 70°

Including lifesize TV BUILDER INSTRUCTIONS
was \$39.49 SLASHED TO **\$32.55**

UNIVERSAL Picture Tube MOUNTING BRACKETS

Fits All 12 1/2" to 21" picture tubes
Complete—Including hand that holds picture tube.



was \$6.97 SLASHED TO **\$4.97**

PULSE KEYED AGC KIT

Finest, most accurate and the easiest Kit to install in a #630 or in any other make TV receiver. Improves performance, and insures a steady picture on all channels.

COMPLETE SET OF PARTS Including 6AU6 tube & Instructions
was \$4.59 SLASHED TO **\$2.99**

72 OHMS COAXIAL CABLE

	Was	Slashed to
100' — hank	\$ 1.84	\$ 3.99
500' — spool	22.99	19.46
1000' — two 500' spools	43.86	37.96



300 OHM TWIN LEAD-IN

	Was	Slashed to
100' — hank	\$ 1.98	\$ 1.12
500' — spool	8.91	4.99
1000' — two 500' spools	17.82	9.78



TV CRYSTAL-CLEAR LUCITE MASKS

Framed in Rich Gold Leaf Finish
Tube Size Overall Dimensions Was Slashed to
17" — Rect. 13 1/2" x 17" \$ 5.97 \$ 4.56
21" — Rect. 15 3/4" x 20 3/4" 8.84 6.92
24" — Round 20 1/2" x 26 1/4" 14.65 11.84
27" — Rect. 21 1/2" x 27" 15.48 12.98
(Including Set of Rosettes)

TV PLASTIC OPEN MASKS

Used in conjunction with safety glass
Was Slashed to
17" — Rect. 14 1/8" x 17 1/2" \$1.87 \$.99
21" — Rect. 18" x 22 5/8" 3.36 1.92
24" — Rect. 21 1/8" x 24 1/4" 6.74 4.93
27" — Rect. 21 1/2" x 27" 7.23 5.87

TV SAFETY GLASS IN HANDY SIZES

	Was	Slashed to
13 3/8" x 16 1/4"	\$2.96	\$1.79
15 7/8" x 20 3/4"	3.72	2.24
16" x 22"	4.29	3.89
17 3/8" x 23 3/8"	5.24	4.12
22 3/4" x 25 3/8"	6.47	5.36
21 1/2" x 27"	6.98	5.64

	Was	Slashed to
PUNCHED CHASSIS PAN, cadmium plated	\$ 4.87	\$ 3.96
630-KIT, screws, nuts, rivets, washers	1.69	1.14
H VOLTAGE CAGE ASSEMBLY, complete	3.73	2.66
VOLTAGE DIVIDER SHIELD & COVER	1.79	1.12
ELECTROLYTIC COND. SUB-CHASSIS	.84	.49
SOUND DISCRIMINATOR SHIELD	.19	.12
DEFLECTION YOKE BRACKET	.29	.18
DEFLECTION YOKE MOUNTING HOOD	.59	.42
FOCUS COIL BRACKETS	set .48	.27
CATHODE TRAP COIL SHIELD	.39	.19
CHASSIS MOUNTING BRACKETS, set of 4	.44	.22
BRIGHTNESS & HOLD CONT'L BRACKET	.59	.39
WIDTH CONTROL BRACKET	.16	.09
TUNER SHAFT BRACKET	.17	.09
FUSE (.25 amp.) & HOLDER	.24	.18
HV RECTIFIER, SOCKET ASSEMBLY, sele	.79	.59
HV RECTIFIER, SOCKET ASSEMBLY, dbl	1.37	.98
TV #1 LINE CORD, with high plug	.29	.22
INTERLOCK SAFETY CONNECTOR (input)	.17	.09
COMP. TERMINAL STRIP KIT, set of 30	.98	.69
AGC BRACKET & SOCKET	.39	.19
MINIATURE WAFER SOCKETS (10) ea.	.07	.04
MINIATURE MOLDED SOCKETS (2) ea.	.12	.07
OCTAL WAFER SOCKETS (13) ea.	.07	.04
WIREWOUND TUBE SOCKET, 18" leads	.39	.22
HV KINESCOPE LEAD	.39	.22
AUDIO OUTPUT TRANSFORMER (#K6)	.69	.49
8" PM SPEAKER, heavy alnico #5 magnet	3.97	2.64
12" PM SPEAKER, heavy alnico #5 magnet	6.94	4.67

H. V. FILTER CONDENSERS—(Cartwheels)

	Was	Slashed to
10kv — 500 mmf	\$.67	\$.10
20kv — 500 mmf	(3) ea. .79	.39

#630 PARTS COMPLETE SETS

	Was	Slashed to
TV WIRE & SOLDER KIT, for any set	\$ 1.49	\$.98
VIDEO AND I.F. KIT, 19 items	7.84	4.99
VARIABLE CONTROL KIT, 9 control	5.83	3.97
CARBON RESISTOR KIT, 107 resistors	6.98	4.98
BRACKET AND WAFER KIT, 18 resistors	2.31	1.76
ELECTROLYTIC CONDENSER KIT, 6 cond.	8.63	6.44
TUBULAR CONDENSER KIT, 38 condensers	4.28	3.63
CERAMIC CONDENSER KIT, 28 condensers	3.37	1.98
MICA CONDENSER KIT, 11 condensers	1.38	.97
TERMINAL STRIP KIT, set of 30	.98	.69
COMPLETE SET OF TUBES, 29 tubes	30.31	24.64

100 ASSORTED TUBULAR CONDENSERS

All are Standard Brands & desirable Sizes
\$3.64
\$15.00 Value was \$4.69 Slashed to

	Was	Slashed to
100— ASSORTED 1/2 WATT RESISTORS	was \$3.97	\$2.88

	Was	Slashed to
15— Asst. Radio Electrolytic CONDENSERS	was \$4.74	\$3.49

	Was	Slashed to
15— Assorted TV Electrolytic CONDENSERS	was \$6.88	\$4.97

	Was	Slashed to
100— ASSORTED MICA CONDENSERS	was \$4.99	\$3.72

	Was	Slashed to
100— ASSORTED CERAMICS CONDENSERS	was \$4.99	\$3.72

	Was	Slashed to
100— ASSORTED 1 WATT RESISTORS	was \$5.86	\$4.62

	Was	Slashed to
100— ASST. PILOT LIGHTS #44, 46, 47, & 51	was \$4.83	\$4.48

	Was	Slashed to
100— ASSORTED SOCKETS Octal, Octal & Miniature	was \$3.92	\$2.79

	Was	Slashed to
100— ASSORTED KNOBS SCREW & PUSH-ON	was \$3.97	\$2.84

	Was	Slashed to
10— VOLUME CONTROLS ASSORTED, WITH SWITCH 1/4, 1/2, 1, 2 meg. and others	was \$2.94	\$2.63

	Was	Slashed to
10— VOLUME CONTROLS ASSORTED, LESS SWITCH 1/4, 1/2, 1, 2 meg. and others	was \$1.94	\$1.66

OVER 100 BARGAINS!

SELENIUM RECTIFIER 65ma.....	S .44
SELENIUM RECTIFIER 75ma.....	.56
SELENIUM RECTIFIER 100ma.....	.69
SELENIUM RECTIFIER 150ma.....	.74
SELENIUM RECTIFIER 300ma.....	1.28
SELENIUM RECTIFIER 350ma.....	1.61
SELENIUM RECTIFIER 400ma.....	1.77
SELENIUM RECTIFIER 450ma.....	1.89
SELENIUM RECTIFIER 500ma.....	1.98
4" PM SPEAKER, alnico #5, 1 oz. magnet.....	1.12
5" PM SPEAKER, alnico #5 1 oz. magnet.....	1.19
6" PM SPEAKER, alnico #5 1 oz magnet.....	1.38
AUDIO OUTPUT TRANSFORMER (50L6).....	.29
AUDIO OUTPUT TRANSFORMER (6K6).....	.49
AUDIO OUTPUT TRANS. (universal any tube).....	.79
VOLUME CONTROL, L/S 1/4, 1/2, 1 or 2 meg.....	.22
VOLUME CONTROL, W/S 1/4, 1/2, 1 or 2 meg.....	.42
VARI-LOOPSTICK ANTENNA.....	.39
I.F. TRANSFORMER COIL, 456kc.....	.28
I.F. TRANSFORMER COIL, FM 10.7mc.....	.28
VARIABLE CONDENSER, 2 gang super.....	.39
6-FOOT LINE CORD WITH MOLDED PLUG.....	.14
SAPPHIRE PHONOGRAPH NEEDLE.....	.49
PHONO MOTOR 78 rpm, complete with t.t.....	2.62
PHONO MOTOR 3 speed, complete with t.t.....	4.47
PHONO AMPLIFIER, incl. 3 tubes.....	4.68
FAMOUS MAKE CRYSTAL PICKUP.....	2.42
CRYSTAL PICKUP, 33, 45 & 78 rpm.....	3.99
TOGGLE SWITCH, DPDT.....	.39
100 WATT ELECTRIC SOLDERING IRON.....	1.74
1 Lb. ROSIN CORE SOLDER 40/60.....	.78
TV POWER TRANSFORMER, 250ma.....	3.98
TV BACK CUP, for recessing CRT.....	.39
12-ASST. TV HANDY BRACKETS..... all for	.95
12-ASST. TV COILS..... all for	.59
TV STATIONARY HV CAGE.....	.79
TV CORONA BUTTONS.....	.01
CORONA RINGS.....	.06
RCA FLYBACK TRANSFORMER, doubler type.....	1.17
GEN. ELECTRIC AGC WIDTH COIL.....	.19
TV CONVERTER COILS.....	.39
TV VERTICAL OUTPUT TRANSFORMER 10 to 1.....	.97
TV WIRE WOUND RESISTOR 5300/2-500 ohms.....	.12
QUARTER AMP. FUSE.....	.02
TV ELECTROLYTIC SUB CHASSIS.....	.17
TV CONICAL ROOF ANTENNA.....	2.69
TV CONICAL ROOF ANTENNA, double.....	4.88
TV FLYBACK TRANS. single 1B3.....	2.54
COAXIAL CABLE, #RG-11U, 1000 feet.....	87.50
TV 90° deflection yokes.....	5.98
TV FLYBACK TRANS. for 90° TV Chassis.....	4.42
LUCITE TV SUB CHASSIS, for HV section.....	2.26
ELECTROLYTIC CONDENSER, 8mfd 450v.....	.22
TV ELECTROLYTIC CONDENSER 1000/250mfd.....	.24
TV PICTURE TUBE BRIGHTENER, complete.....	.99
TV 50° DEFLECTION YOKES.....	.58
TV FOCUS COILS, 250 ohms.....	.99
REGENCY \$49.95 UHF CONVERTER, Comp.....	29.97
PHILCO \$39.95 TV BOOSTER, complete.....	9.98
14" PICTURE TUBE, standard brand.....	14.37
5-TUBE TABLE MODEL RADIO, complete.....	13.89
TV GENERATOR for TEST PATTERN.....	39.97
#630 CHASSIS PAN, with sockets on.....	5.94
UHF STRIPS—F, 22, 25, 26, 27, 28, 33, 34, 38.....	3.99
UHF STRIPS—F, 39, 40, 41, 45, 46, 48, 49, 54.....	3.99
UHF STRIPS—F, 55, 59, 67, 71, 73, 78.....	3.99
UHF STRIPS—K, 17, 24, 34, 39, 45, 48, 57, 73.....	3.99
UHF STRIPS—Q, 36, 39, 45, 46, 55, 61, 66, 69.....	3.99
VHF STRIPS—F, 6, 8, 10, 12 osc. or antenna.....	.49
VHF STRIPS—Q, 6, 8, 10, 12 osc. or antenna.....	.49
100—SMALL PEANUT TUBE CART. 1"x1/2"x1/8".....	.79
100—LARGE PEANUT TUBE CART. 1"x1/2"x3/4".....	.94
100—GT TYPE TUBE CART. 1 1/2"x1/4"x3/8".....	1.04
100—SMALL G TUBE CART. 1 1/2"x1/2"x4 1/8".....	1.29
100—LARGE G TUBE CARTONS 2"x2"x5 1/8".....	1.59
100—EXTRA LARGE TUB. CART. 2 1/2"x2 1/4"x6 1/2".....	2.67
RADIO TUBULAR CONDENSER 25-600v.....	.12
RADIO TUBULAR CONDENSER 5-600v.....	.19
RADIO TUBULAR CONDENSER 20/20-150v.....	.37
RADIO TUBULAR CONDENSER 50/30-150v.....	.39
RADIO TUBULAR CONDENSER 16/16-450v.....	.59
RADIO TUBULAR CONDENSER 40-450v.....	.64

Closing out excess stock of New Guaranteed Receiving Tubes in Standard Brands:

1H5—56, 1Q5—49, 1LE3—64, 1LD5—49, 1LB4—49, 1T5—49, 1LC6—49, 1LH4—49, 6AK5—69, 6C5—52, 6AB7—54, 6H6—39, 6C4—52, 6F5—39, 6Q7—49, 6J7—49, 6A7—49, 6A8—52, 6SD7—49, 6SF7—49, 6SF5—45, 6SJ7—49, 6AV6—54, 6SA7—49, 6BE6—49, 7F8—49, 7F7—49, 7Y4—44, 7V7—47, 7E7—49, 7A8—57, 7A6—48, 12AL5—49, 12SJ7—45, 12SK7—49, 12SA7—54, 12SR7—42, 12SL7—39, 12SG7—52, 14A7—49, 25L6—52, 25A6—49, 35A5—56, 37—07, 39/44—07, 43—36, 1B3—74, 5U4—49, 6AT6—42, 6AL5—44, 6AG5—59, 6A6—59, 6AU6—57, 6AC7—99, 6SN7—72, 6SH7—48, 6SK7—49, 6J5—36, 6BG6—1.87, 5V4—1.19, 6K6—59.

BROOKS RADIO & TV CORP.
84 Vesey St., Dept. A, New York 7, N. Y.

OCTOBER, 1954

RADIO

AN EFFICIENT CW DETECTOR

By CHARLES ERWIN COHN

In most present-day communication sets, an ordinary diode detector is used for CW reception. The b.f.o. voltage is coupled very loosely through a gimmick capacitor. This system has two major disadvantages. First, the b.f.o. voltage in the diode detector generates an a.v.c. voltage even with no signal applied. This loss of sensitivity prevents the use of a.v.c. for CW reception. Second, the loose coupling to the b.f.o. causes a considerable reduction in conversion gain in the second detector.

Since CW detection is essentially a conversion process, the circuits used in superhet conversion could be used. The first that comes to mind is the conventional pentagrid circuit, with the oscillator section used as the b.f.o. However, this circuit cannot be used because the oscillating space charge produced in the oscillator section induces a voltage on the signal grid, depending on the impedance presented to the oscillator signal. Since the b.f.o. is tuned very close to the i.f., the impedance is very high. Enough voltage will be induced to block the tube. This is the same action used in the gated-beam FM detector. This effect can be overcome by reversing the order of the grids, using the first grid for signal and the third grid for oscillator injection. This is shown in the diagram.

A separate oscillator must be used. But this is no disadvantage, as the only extra cost is that of the tube. The

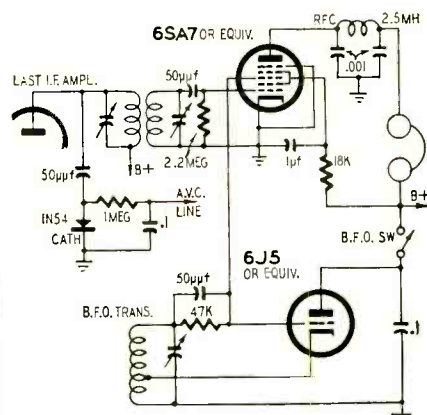

Schematic diagram of CW detector.

b.f.o. may be shut off by the switch in its plate circuit (under this condition the grid leak and capacitor in the first grid circuit will detect phone signals).

Almost any pentagrid tube can be used. The connections are shown for a 6SA7 (or 6BE6), but a 6A8 may be used. If extremely large signals are to be handled, the 6L7, which has a remote-cutoff first grid, is preferable. Phones are shown in the plate circuit because this detector will give ample headphone output with the usual run of



New, 300-page
Centralab
Control Guide
No. 14

Here's the place to look

when you want service facts on any radio or TV control

At your
Centralab distributor... \$1.50

Here's the only up-to-date reference book that lists all the radio and television controls used since 1927 by every set manufacturer. Just look at this partial table of contents:

- Centralab Control catalog pages.
- Popularity listing of stock television controls.
- Index of television manufacturers.
- Complete television guide listings.
- Popularity listing of stock radio and audio controls.
- Index of manufacturers of radios and audio equipment.
- Complete radio guide listings.
- Complete audio guide listings.
- Control replacements listed by part number.
- Complete specifications of CRL custom controls.
- Cross-references from CRL numbers to manufacturers' numbers, with popularity listing.
- Listing of discontinued Centralab part numbers and current replacements.
- Cross-reference of control manufacturers' part numbers.
- Complete listings on the new "Fastatch" Duals and "Snap-Tite" Controls.

We miss our guess, if you don't find the Centralab Volume Control Guide No. 14 one of the most helpful working tools you have — in the time it saves you — and in the money it saves you.

Ask your Centralab distributor to let you see a copy. See if you don't agree that it's the biggest dollar-and-a-half's worth you've run across in a long, long time.

Then take advantage of this bargain, as a sound investment in your business.

Centralab

G-2554

103

INSURE CUSTOMER SATISFACTION . . .

OHMITE®



Little Devil
**COMPOSITION
RESISTORS**

Provide an
**EXTRA MARGIN
OF SAFETY**

● You can eliminate "call-backs" and insure customer satisfaction by standardizing on Ohmite "Little Devil" composition resistors. These tiny units provide an *extra margin of safety* on your repair jobs. For example, they are rated at 70C instead of the usual 40C . . . and they meet all test requirements of MIL-R-11A, including salt water immersion and high humidity tests without wax impregnation. Ohmite "Little Devil" resistors are available in ½, 1, and 2-watt sizes ($\pm 5\%$ or $\pm 10\%$ tolerance) in all RETMA values. Order from your distributor, today.

Other Dependable
OHMITE Products

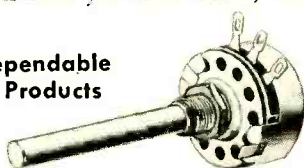

Type AB Noise-Free Potentiometers

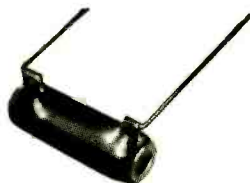

BROWN DEVIL Wire-Wound Resistors

Be Right with
OHMITE®

DEPENDABLE RESISTANCE UNITS



Write for
Stock
Catalog

OHMITE MANUFACTURING CO.
3646 Howard Street, Skokie, Illinois
(Suburb of Chicago)

RADIO

i.f. signals. If a speaker is desired, the headphones can be replaced in the circuit with an audio transformer or choke for coupling to the output stage.

This circuit has two important advantages over the usual diode detector with loose b.f.o. coupling. First, the sensitivity is very much greater. In fact, if you rig up this circuit temporarily, with a signal generator to grid 3 and a short indoor antenna direct to grid 1, you can get clearly audible signals from the local broadcast stations. Such extreme sensitivity simplifies receiver design by reducing the gain necessary in the rest of the receiver.

The second great advantage of this circuit is that it allows a.v.c. to be used on CW signals, since the b.f.o. is almost completely isolated from the i.f. circuit. The a.v.c. should be taken from a separate rectifier fed from the plate of the last i.f. tube (see diagram). Here a 1N54 high back-resistance diode is used as an a.v.c. rectifier, with the diode back resistance serving as the load for the circuit. Of course, the b.f.o. circuits should be well shielded to prevent b.f.o. voltage from getting into the i.f. or front-end circuits by stray coupling. This can cause blocking of the a.v.c. and birdies due to harmonics. END

Dirty Word

by Jeanne DeGood

Ah, dust we are—
To dust returneth;
If dust we are,
It maketh me burneth.

A dusty chassis
Cannot be seeneth—
They leave the chassis
For me to cleaneth!

Radio Thirty-Five Years Ago In Gernsback Publications

HUGO GERNSBACK Founder

Modern Electrics	1908
Wireless Association of America	1908
Electrical Experimenter	1913
Radio News	1919
Science & Invention	1920
Television	1927
Radio-Craft	1929
Short-Wave Craft	1930
Television News	1931

Some of the larger libraries still have copies of **ELECTRICAL EXPERIMENTER** on file for interested readers.

In October, 1920 *Science and Invention* (formerly *Electrical Experimenter*)

Reporting Yacht Races via Radio, by Donald McNichol

Radio Power Transmission, by Samuel Cohen

Simplest Long Wave Receiver, by Elliott A. White

How to Become a Professional Radio Man, by Pierre H. Boucheron

Ship's Radiophone Heard 500 Miles

new!

... SUPER PERFORMANCE

PHILCO

TV

ANTENNAS

**GUARANTEED TO
OUTPERFORM
ANY equivalent type antenna or
YOUR MONEY
and
LABOR COSTS
BACK!**

Enough words have been written about TV antenna performance. *Now, see the facts for yourself!* Compare any of the new PHILCO Super Performance TV Antennas with any equivalent type on the market. If the new PHILCO does not give you the finest picture possible, your money back for the antenna *plus* your labor costs up to \$10.00. Here at last is *real* guaranteed performance! PHILCO TV Antennas provide gains up to 15 db in some models... strong signal pickup... high front to back ratio. Powerful Conical... all-aluminum VHF Yagis, engineered for quick rigging... light weight. Stacked versions provide top-quality fringe area reception. Six UHF Yagis cover the entire UHF spectrum.

GET YOUR "FREE RIDE" WITH PHILCO • SEE YOUR PHILCO DISTRIBUTOR!

**PHILCO CORPORATION
ACCESSORY DIVISION**

"A" and Allegheny Ave. • Philadelphia 34, Pa.

**BUY
QUALITY...**

BUY *TRIO*

Uses Famous New "INSTA-LOK" Clamp

**THE
TRIO
VARI-CON**

ADJUSTABLE For Higher Gain On The Channels Of Your Choice

CHANNELS
2 thru 83

- 10 seconds assembly and peaking time
- Only antenna with spring dampeners—lessens element breakage
- "Insta-Lok" Clamp, revolutionary new parasitic element support for instant, permanent alignment. Locking strength exceeds element strength.
- New Mycastyrene insulators.
- Available in 1, 2, 3 & 4 bay models for ultra-fringe or all-channel reception.

***TRIO* 88**

Far superior construction. Rugged, foolproof—easily installed. Parasitic elements supported by TRIO's revolutionary new "Insta-Lok" clamps. Low channel dipoles supported by the strongest conical head made. No vibration—No element shedding. Completely pre-assembled. Available in single or two bay models.

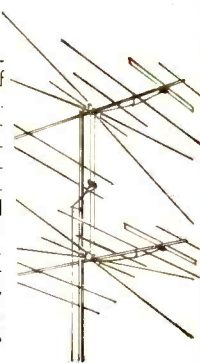

***TRIO* 66**

Three dipoles provide exceptionally high gain on all VHF channels. Exclusive TRIO grid reflector gives improved performance. Extremely rugged yet lightweight. Pre-assembled—simply unfold and tighten reflector and dipole assemblies. Three vertical braces on reflector screen for increased strength. Available in single or two bay models.

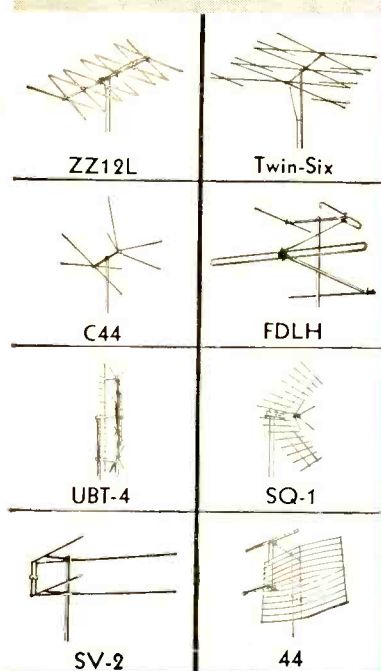
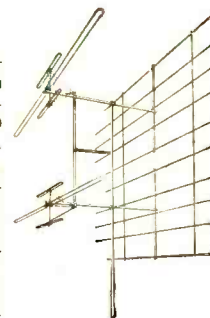

Ask To See America's Most Dependable And Beautiful Rotator:

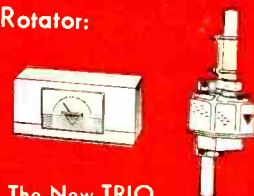
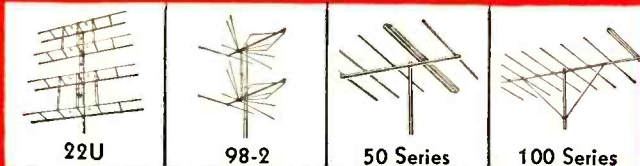

The New TRIO
"ARISTOCRAT"

TRIO
Manufacturing Co.
GRIGGSVILLE, ILLINOIS

TRIO Leader in Antenna Development

**AMERICA'S MOST
DEPENDABLE ROTATOR**

THE TRIO
"ARISTOCRAT"

NOW...

*America's
most
beautiful!*



The sleek, modern, low silhouette of the new TRIO rotator control case marks a new high in styling.

Beauty, here, is more than skin deep since its low center of gravity makes it tip-proof! Note, too, that there are NO unsightly control knobs or switches to spoil its beauty. These are located at top rear of case — where your hand naturally rests in operation of rotator!

There is no obscuring the easily-read lighted dial. Available in either blonde or mahogany, the unit with its graceful flowing lines blends perfectly with any decor.

Yes, America's most dependable rotator is now America's most beautiful as well!

Switch and directional controls are located at top rear of case for most convenient manual operation. Lighted dial permits operation in darkened room and also indicates when rotator is on. When on, pointer always shows exact position of antenna.



✓ Only Rotator With Two Motors

✓ Only Rotator With Two-Year Guarantee



THE TRIO
"ARISTOCRAT"

... CULMINATION OF
SIX YEARS RESEARCH
AND PRODUCTION



TRIO

Manufacturing Co.
GRIGGSVILLE, ILLINOIS

Patents

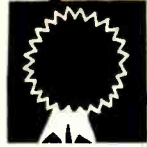

U.H.F. FREQUENCY METER

Patent No. 2,681,434

Harold A. Wheeler, Great Neck, N.Y.
(assigned to Boonton Radio Corp.)

Grid-dip meters are useful only to about 300 mc. At higher frequencies, because the meter

cannot be brought close enough to the external circuit being tested, readings become erratic. This new instrument can make measurements even at 1,000 mc. It transmits a signal that is reflected by the external circuit. Reflected power is maximum when the external circuit and the frequency meter are in resonance.

The diagram shows a triode oscillator such as pencil-tube type 5675. A square-wave generator modulates the carrier (S in position A). This wave is transmitted from loop L1 to the external tank. Reflected energy is picked up by loop L2. The loops are fixed at right angles to each other so that there is negligible coupling between them. The carrier is rectified by D1, and the modulation is amplified. The a.f. is rectified by D2 and delivered to the meter. Tank circuit L-C is tuned until the meter indicates maximum deflection. Then this tank, which is calibrated, shows the frequency of the external circuit.

An a.g.c. feature is used in this circuit. It may be a constant-current tube controlled by D3 to maintain constant input to the oscillator. Grid-dip meters cannot use a.g.c. because it would eliminate variations in grid current. When an external oscillator is measured, the

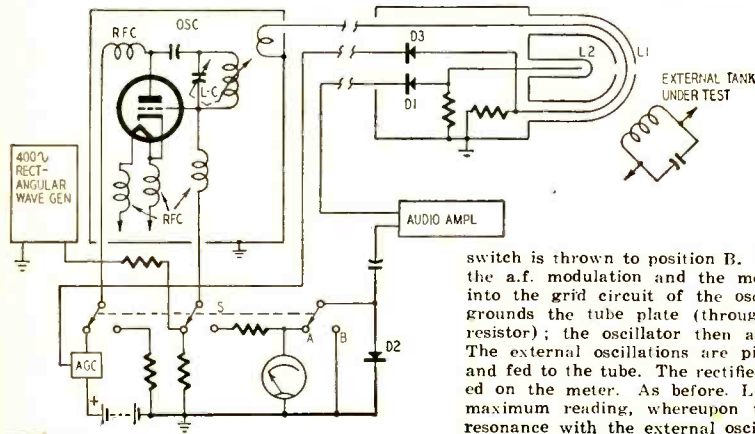

switch is thrown to position B. This disconnects the a.f. modulation and the meter is switched into the grid circuit of the oscillator. It also grounds the tube plate (through a choke and resistor); the oscillator then acts as a diode. The external oscillations are picked up by L1 and fed to the tube. The rectified r.f. is indicated on the meter. As before, L-C is tuned for maximum reading, whereupon this tank is in resonance with the external oscillator.

SQUELCH

Patent No. 2,681,989

Thomas W. Cuniff, Newark, N.J.
(assigned to Int'l. Tel. & Tel. Corp.)

Background interference is a serious problem when a microphone is used in a noisy location such as an engine room or busy factory. It is especially noticeable during absence of transmission, when there is no signal to override it. This squelch circuit blocks the amplifier and quiets the speaker during such periods. Gain is restored when the microphone input exceeds a predetermined level.

Normally the amplifier is blocked by the bat-

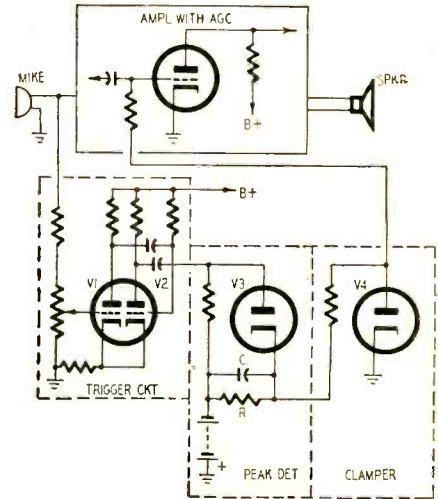

tery voltage. Multivibrator V1-V2 is also blocked. When the mike is spoken into, the positive peaks of the signal unblock the V1 grid. The multivibrator triggers and creates a positive

New TELEVISION COURSE

Amazing Bargain, Complete, Only \$3

PRACTICAL, NEW, LARGE

Here is your complete training in television servicing. These new lessons cover every fact, adjustment and repair of every type and make of TV receivers. Giant in size, mammoth in scope, just like other correspondence courses selling for over \$150. Our amazing offer permits you to obtain the course complete for only \$3, nothing else to pay. Easy-to-follow, well illustrated lessons on circuits, picture faults, adjustments, short cuts, about UHF, alignment, antenna problems, trouble-shooting, service hints, how to use test equipment, and many practical sections prepared by leading manufacturers. Just published. Send trial coupon today and use the complete TV course at our risk. Satisfaction guaranteed. Your price for all lessons in large manual form, complete, post-paid, only \$3. Send trial-coupon now.

COVERS EVERYTHING IN TV

Let these lessons take you into TV servicing the easy way. The very first lesson of this sensational course tells how to do simple repairs. You start earning money immediately. Second lesson tells you what is wrong, by just looking at the picture—no instruments used. Lesson 4 has 32 large, 8 1/2 x 11" pages and 28 large illustrations on practical antenna installations and improvements. Another 12 lessons deal with troubleshooting, stagger-tuned alignment, inter-carrier sets, UHF converters, use of TV test equipment, picture analysis, new circuits, TV facts that puzzled you will be quickly cleared up. Yes, you will find yourself doing TV repairs in minutes—instantly finding faults or making all needed adjustments. Examine this course for 10 days in your own home. Look over this collection of material, read a few lessons, apply some of the hints. Then decide to keep the lessons at the bargain cost of \$3 (full price), or return the material.

RADIO & TV Manuals

Your complete source of all needed RADIO and TV diagrams and service data. Most amazing values. Still sold at pre-Korean prices. Only \$2 to \$3 per volume. Every Radio manual contains large schematics, all needed alignment facts, parts lists, voltage values, trimmers, dial stringing, and service hints. Each TV manual is a practical treatise on servicing a full year's sets, with giant blueprints, waveforms, hints, alignment and voltage charts, production changes. See coupon at right for a complete list of these low-priced Supreme service manuals.

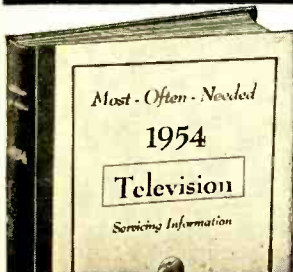

Supreme Publications
Sold by All Leading Parts Jobbers

NO-RISK TRIAL ORDER COUPON

SUPREME PUBLICATIONS, 1760 Balsam Rd., Highland Park, Ill.

Send TV manuals checked below and Radio manuals at right. Your satisfaction guaranteed or your money refunded.

- New Television Servicing Course, complete... \$3.
- Latest 1954 Television Servicing Manual, only... \$3.
- 1953 TV Manual, \$3. 1953 UHF Units, \$1.50
- 1952 Television Manual, \$3. 1951 TV, \$3.
- 1950 Television Manual, \$3. 1949 TV, \$3.
- 1948 TV, \$3. 1947 TV & FM, only \$2.

- I am enclosing \$..... Send postpaid.
- Send C.O.D. I am enclosing \$..... deposit.

Name:

Address:

Radio Diagram Manuals

- New 1954 Manual, \$2.50
- 1953 Radio Manual, \$2.50
- 1952 Radio
- 1951 Diagrams
- 1950 Manual
- 1949 Radio
- 1948
- 1947
- 1946
- 1942
- 1941
- 1940
- 1939
- 1926-1938 Manual, \$2.50
- Master INDEX only 25¢

EACH \$2.50
PRICED AT ONLY \$2 EACH



**YOUR ELECTRONIC
EQUIPMENT**
Demands Highly Specialized
WIRE

THE MANUFACTURERS
AND SERVICE MEN
WHO SERVE BEST

Specify

Belden

WIREMAKER FOR INDUSTRY

OUTSTANDING for HIGH FIDELITY!

BUY DIRECT AND SAVE

'PRE-FAB' COLLINS TUNERS and RECEIVERS
AUDIO PRODUCTS CO.

NOW! with AFC

Collins Audio Products Co. is in no way affiliated with Collins Radio Co.

Each Collins Tuner Kit is complete with punched chassis, tubes, power transformer, power supply components, hardware, dial assembly, tuning eye, knobs, wire, etc., as well as the completed sub-assemblies: FM tuning units, AM tuning units, IF amplifiers, etc., where applicable. All sub-assemblies wired, tested and aligned at the factory make Collins Pre-Fab Kits easy to assemble even without technical knowledge. The end result is a fine, high quality, high fidelity instrument at often less than half the cost—because you helped make it and bought it direct from the factory.

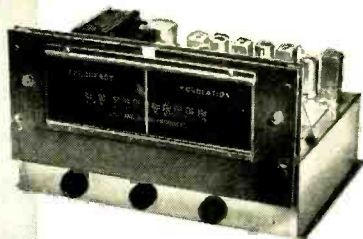

FM Tuner Kit

\$55

with AFC \$58.50

The FM-11 tuner is available in kit form with the IF Amplifier mounted in the chassis, wired and tested by us. You mount the completed RF Tuning Unit and power supply, then after some simple wiring, it's all set to operate. 11 tubes: 6J6 RF amp, 6AG5 converter, 6C4 oscillator, 6BA6 1st IF, (2) 6AU6 2nd and 3rd IF, (2) 6AU6 limiters, 6AL5 discriminator, 6AL7-GT double tuning eye, 5Y3-GT rectifier. Sensitivity 6 to 10 microvolts, less than 1/2 of 1% distortion, 20 to 20,000 cycle response with 2DB variation. Chassis dimensions: 12 1/2" wide, 8" deep, 7" high. Illustrated manual supplied. Shipping weight 14 lbs.

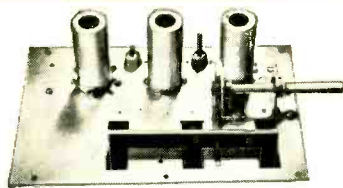

FMF-3 Tuning Unit

\$15.25

with AFC \$18.75

The best for FM. The most sensitive and most selective type of "front end" on the market. 6 to 10 microvolts sensitivity. Image ratio 500 to 1. 6J6 tuned RF stage, 6AG5 converter, 6C4 oscillator. Permeability tuned, stable and drift-free. Chassis plate measures 6 1/2" x 4 1/2". In combination with the IF-6 amplifier, the highest order of sensitivity on FM can be attained. Tubes included as well as schematic and instructions. Draws 30 ma. Shipping weight FMF-3: 2 1/2 lbs. Dial available @ \$3.85.

IF-6 Amplifier

\$19.75

6 Tubes, Shipping Wgt. 3 lbs.

FOR USERS OF COLLINS TUNERS:

Receive \$5.00 credit toward the new FMF-3A front end! Mail us your old front end with \$13.75 and we will send you the new, improved FMF-3A with AFC, or, remit the full amount of \$18.75 and when we receive your old unit in return a check will be mailed you for \$5.00.



AM-4 Tuning Unit

\$24.50

Tops in AM superhet performance! A 3-gang tuning condenser gives 3 tuned stages with high sensitivity and selectivity. Assembly is completely wired, tested and aligned ready for immediate use. Frequency coverage 540 KC to 1650 KC at a sensitivity of 5 microvolts. Tubes 6BA6 RF amplifier; 6BE6 converter; 6BA6 IF amplifier and 6AT6 detector. Draws 30 ma @ 220 volts. Mounts on a chassis plate measuring 4" x 7 3/8". Shipping weight 2 1/2 lbs. Dial available at \$3.85.



FM/AM Tuner Kit

\$77.50

with AFC \$81.00

The original 15 tube deluxe FM/AM pre-fab kit redesigned on a smaller chassis. The tuner now measures 14" wide by 12" deep by 7 1/2" high. This attractive new front and dial assembly opens up new applications where space is at a premium. Kit includes everything necessary to put it into operation—punched chassis, tubes, wired and aligned components, power supply, hardware, etc. Kit comprises FMF-3 tuning unit, IF-6 amplifier, AM-4 AM tuning unit, magic eye assembly and complete instructions. All tubes included. Shipping weight 19 lbs.

MAIL COUPON TODAY

To: Collins Audio Products Co. Inc. RE-10
P.O. Box 248, Westfield, N. J.
Tel. Westfield 2-4290

- FM Tuner Kit FM/AM Tuner Kit FMF-3 Tuning Unit
- with AFC with AFC with AFC
- IF-6 Amplifier AM-4 Tuning Unit

NAME _____
ADDRESS _____
CITY _____ STATE _____
Amount for Kit \$ _____ See weights, add shipping cost \$ _____
Total amount enclosed \$ _____ Check Money Order

square wave. Then V3 conducts. The drop across R opposes and overcomes the battery voltage. Now V4 also conducts and clamps the amplifier grid at ground potential.

Network R-C is designed for minimum charging time, so the squeelch goes into action quickly.

R.F. EQUALIZER

Patent No. 2,682,037

Stephen Bobis and Walter R. Lundry, Summit, N.J.

(assigned to Bell Telephone Labs, Inc.)

Audio lines are often equalized by filters. The method described here is also applicable to r.f. lines. Each network (N1, N2, N3) is tuned to a different frequency within the desired range. This may be in the video-frequency range, for

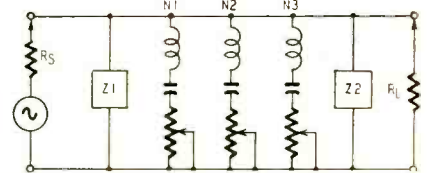

example. Each network has its own loss control to remove peaks or dips in the frequency response curve.

Z1, Z2 are used to flatten the curve at the low or high ends, or to compensate for defects in the frequency response of Rs or RL.

LOW-VALUE CAPACITOR

Patent No. 2,677,799

Harry R. Foster, Lake Valhalla, and Elmor E. Crump, W. Caldwell, N.J. (Assigned to Omega Laboratories)

Certain compounds of titanium show remarkable properties. Their dielectric constant is very high, being 1,000 or more. Furthermore, this value is variable over a wide range, and can be controlled by a voltage across it. These characteristics were described on page 92 in the February, 1954, issue.

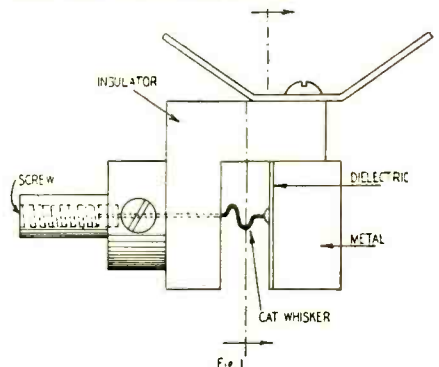

Previous capacitors of this type had relatively large values, because the dielectric constant is so high. For v.h.f. work, low capacitance is needed in tank circuits—for example, TV sweep generators. This invention fills a

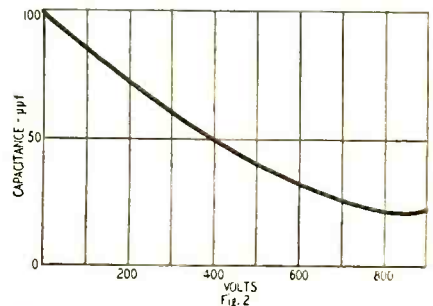

definite need by disclosing a capacitor with a value smaller than 100 pF. Its construction is shown in Fig. 1.

An insulator holds a block of metal as shown. The inner surface of the metal is coated with a very thin layer of the high-dielectric material. Then the free side of the dielectric is painted with a dot of silver. A catwhisker, adjusted by the screw, contacts the silver.

(Continued on page 114)

WHEN YOU THINK OF TUNERS, THINK OF COLLINS AUDIO PRODUCTS



Speaking of Speakers...

DELCO RADIO CAREFULLY CONTROLS THE MANUFACTURING OF ITS SPEAKERS TO ASSURE HIGHEST POSSIBLE QUALITY

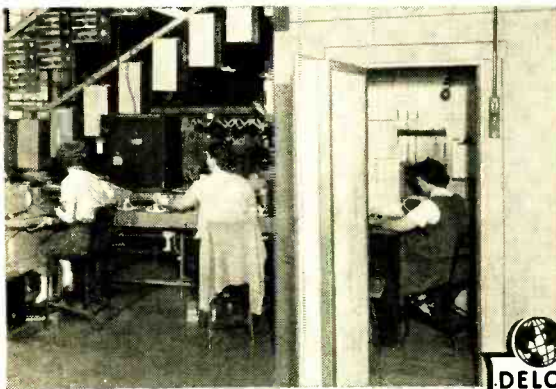

In the audio test booth, the speaker is checked for its ability to deliver good listening. In the background you can see a small section of the speaker production line.



High quality in the final product can be had only through rigid quality control. Take speakers, for example. Speaker baskets are formed in our stamping department. Special machines wind the voice coils. On the assembly line the cones are secured to the voice coils and then assembled with the basket. All along the line inspectors have been checking and rechecking. Then, the speaker is magnetized and goes into a specially designed sound booth for a final check.

This continuing quality control is one important reason why Delco Radio replacement parts assure customer satisfaction. Made by the world's largest manufacturer of auto radios, they are available from your UMS Delco Electronic Parts Distributor.

**DISTRIBUTED BY
ELECTRONIC PARTS
DISTRIBUTORS
EVERYWHERE**

DELCO RADIO
DIVISION OF GENERAL MOTORS CORPORATION, KOKOMO, INDIANA

A GENERAL MOTORS PRODUCT   A UNITED MOTORS LINE

HERSHEL RADIO CO. BIGGEST BUYS!

FIL. TRANSFORMER PRI. 117V. 60 cycle



Sec.,
 =16.4v 12amp.
 =26.4v 10amp.
 =33.5 v 3amp.
 =45 v 3amp.
 =55 v 3amp.
 =62.5v 1.75amp.

\$4.95

SIZE: 5 1/16" x 5 1/16" x 5 1/4" H.

RCA OUTPUT



TRANSFORMER

P.P. 6L6'S 25 watt
 PRI 5000 Ohms Sec. #1
 500 Ohms. Sec. #2
 600 Ohms. Sidetone 15 to
 15,000 cy. flat.

\$1.95

FILTER UNITS



\$2.95 FL-41
 Phone plug and
 lock JK34 2
 BINDING POST.
 Features RF
 Feed Back. Has
 2 RF CHOKES,
 72 UH Powered
 Iron Core.

2 METER ANTENNA



GROUND PLANE
 CT2 66-AFJ
 144 MC to
 156 MC

\$9.95

OIL COND.

MFD	VDC	PRICE
.05	3000	\$1.95
.05	7500	2.29
.1	4000	1.29
.1	7000	1.75
.1	7500	2.49
.5	2500	1.75
2 x .5	8000	1.49
1	3000	2.49
1	3600	2.95
1	5000	4.95
2	600	.49
2	1000	.95
2	3000	4.95
4	1000	1.95
6	600	1.29
7	600	1.39
8	600	1.75
8	1000	2.49
10	600	2.49
10	1500	4.95

DUAL	4-1000	PRICE
2x4	600	3.95
13.5	220 vac.	1.95
6	330 vac.	.95

PAPER CAN

MFD	VDC	PRICE
250	10	\$.39
500	12	.49
1000	3	.69
1000	15	.95
1000	25	1.29
1200	10	.95
1600	15	1.29
24000	3	1.49
117	110 vac.	1.45

PHOTO-FLASH SPECIAL!

MFD	VDC	PRICE
525	450	\$9.95

1 KW ANT. CHANGEOVER

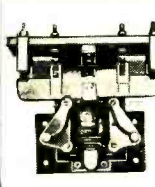

RELAY

110 VAC
 60 Cycle
 15 Amp
 2500 Volt
 D. P. D. T.

\$9.95

BUTTERFLY CONDENSERS

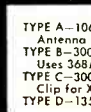

TYPE A-106-330 MC-
 Antenna Type
 TYPE B-300-1000 MC-
 Uses 368AS tube
 TYPE C-300-1000 MC-
 Clip for Xial Det.
 TYPE D-135-485 MC

YOUR CHOICE \$4.95

MODULATION and DRIVER TRANSFORMERS



\$4.95 for Both
 Modulation
 trans. 815 Class
 AB2 56 Watt
 DRIVER, 65N7
 to Modulator.

VIBRATOR SUPPLIES

PE 117C **YOUR CHOICE**
 Input 6 or 12V DC to Supply
 Fil. and Plate Power.
 Used with BC 659.

PE 204C **9.95**
 Input 12V DC. Supply Fil.
 and Plate Supply. Used
 with EE99.

CHOKO SPECIALS!

DUAL 4.5	120MA	\$ 1.95
4.5	70MA	
DUAL 1H	400MA	\$2.95
4.2H	75MA	
15H	80MA 385 OHM	\$ 1.95
2-7H.	Swinging 550MA	\$ 5.95

PLATE TRANS. only



PRI. 90 v
 60 cy.
 3 amp. Sec. #1 6400
 v. #2 1amp. 674 x
 5 3/4 x 6 1/4 H.

\$9.95

TELEGRAPH SOUNDER



Main Line 150
 ohms. Attn. C.A.P.

\$1.95

TERMS: Cash with order or 25%
 DOWN—BALANCE C.O.D. NET
 10 DAYS—RATED ACCOUNTS
 ALL PRICES NET F.O.B. DETROIT
 Merchandise Subject to Prior Sale

5245 GRAND RIVER

Detroit 8, Michigan

Phone TYler 8-9400

HERSHEL RADIO CO.

NOW... PLAY the NEW PRE-RECORDED TAPES WITH FULL FREQUENCY RANGE



**HIGH FIDELITY
DYNAMU
CONVERSION KITS**

20-15,000
CYCLES
at 7.5"!

INCREASED
FIDELITY &
FREQUENCY
RANGE

REDUCED
HUM and
DISTORTION

At last, exciting new High Fidelity performance from home type tape mechanisms... record and playback HEADS need no longer be a limiting factor in frequency response and fidelity.

DYNAMU's superb new precision and quality will deliver previously unobtainable response to the input of your amplifier... 20 to 15,000 cycles at 7.5"! Play the new pre-recorded tapes with full frequency range!

DYNAMU Conversion Kits contain all components to convert your recorder. Complete illustrated step-by-step instructions are included for installation and electrical changes.

CONVERSION KITS FOR LEADING RECORDERS AVAILABLE...

SEE them, HEAR them, NOW... Ask your Hi Fi Dealer.

DYNAMU MAGNETRONICS CORPORATION
 A Division of The Maico Co., Inc.
 Maico Bldg., Minneapolis, Minn.

RECEIVING TUBES

BRANDED—INDIVIDUALLY BOXED
 GUARANTEED 6 MONTHS

6AQ5	\$.50	6C4	\$.40	7A7	\$.69
6AT6	.. .40	6SA7GT	.. .55	7B6	.. .69
6AU6	.. .45	6SK7GT	.. .53	7B8	.. .69
6AV6	.. .40	6SN7GT	.. .59	7C5	.. .59
6BA6	.. .40	6V6GT	.. .50	7E6	.. .39
6BE6	.. .40	6X4	.. .40	7Y4	.. .69

(Write for types not listed)

TERMS: 25% with order, balance C.O.D. Orders over \$15.00 with full remittance, prepaid to you in Continental U.S.A. Prices subject to change without notice. Minimum order \$5.00.

DORIAN ELECTRONICS CORP.
 89-39 163rd St., Jamaica 32, N.Y.



THE UNITED WAY

OPPORTUNITY ADLETS

Rates—45c per word (including name, address and initials). Minimum ad 10 words. Cash must accompany all ads except those placed by accredited agencies. Discount, 10% for 12 consecutive issues. Misleading or objectionable ads not accepted. Copy for Nov. issue must reach us before Sept. 15, 1954.

Radio-Electronics

25 W. Broadway, New York 7, N. Y.

SPEAKER REPAIRS ON ALL MAKES 8" & 12" HI-FI speakers for sale. Amprite Speaker Service, 70 Vesey St., New York 7, N.Y.

ALL MAKES of test equipment repaired, and kits constructed. Send for free information. Bigelow Electronics, Pioneer Road, Beulah Michigan.

TELEVISION FOR EVERYBODY: each tube's purpose from Antenna to Picture Tube, no theory. \$1.50. Bursha, 918 Bath, Ann Arbor, Michigan.

SPEAKER RECONING: Guaranteed workmanship. C&M Recome Co., 255 Tiosa St., Trenton 9, N.J.

BEST TELEVISION ANTENNA made \$4.95. Derr, 1018 Taylor, Vallejo, California.

DIAGRAMS FOR REPAIRING RADIOS \$1.00. Record Changers \$1.50. Television \$2.00. Give Make, Model. Diagram Service, 672-RE, Hartford 1, Conn.

CUSTOM BUILDING and CALIBRATION OF STAND-ard kit test equipment, Heath, Eico, etc. Write for price list. C. Duval, Linlier Beach, Va.

NOW AT LAST. A pocket P-M radio self-contained tunes 87.5 to 108.5 MC. plans \$1.00 and self-addressed envelope. 6000 mile range subminiature set 535 kc to 16 meters. Plans 50c and self-addressed envelope. Beginner's broadcast kit with subminiature tube, less batteries and phone, \$5.95 postpaid. U.S. Only. 25% deposit on all C.O.D. orders. Ekeradio, 646 N. Fair Oaks Ave., Pasadena, California.

128 page TOOL CATALOG \$1.—EXCELSIOR. 8400 Tibet, El Paso, Texas.

TEST EQUIPMENT REPAIRED—New mod-in lab equipped to handle all makes and types of meters and testers. Free estimates. Catalogue available. General Electronic Dist. Co., 100 Park Place, N.Y. 7, N.Y.

TUBES—TV, RADIO, TRANSMITTING, AND SPECIAL PURPOSE TYPES BOUGHT, SOLD AND EX-CHANGED. Send details to B. N. Geisler W2LX1, 136 Liberty, N. Y. 6, N. Y.

ALL MAKES OF ELECTRICAL INSTRUMENTS AND TESTING equipment repaired. Write for free catalogue on new and used instruments at a savings. Hazleton Instrument Co., 128 Liberty Street, New York, N. Y.

WRIST RADIO. Amazingly powerful! Plays while wearing. Plans, kits, complete sets. CODE PRACTICE oscillator kit \$1.00. Huckert Electronics, Box 1400-E, Washington 4, D.C.

TELEVISION SETS, \$19.95 up. Jones Radio, 1115 Rumber, Pottstown, Pa.

BUILD YOUR OWN ELECTRONIC ORGAN, OR MINIA-TURE electronic brain. Jim Kirk, W6KX, 1552 Church Street, San Francisco 14, California.

WANTED: AN/APR-4, other "APR.", "TS.", "IE.", ARC-1, ARC-3, ART-13, BC-348, etc. Microwave Equip-ment. Everything Surplus. Special tubes. Tee Manuals, Lab Quality Equipment, Meters. Fast Action. Fair Treat-ment. Top Dollar! Littell, Fairhills Box 26, Dayton 9, Ohio.

BUY WHOLESALE—25,000 items—Catalog 25c. Mat-thews, 1472-11 Broadway, NYC 36.

ALUMINUM TUNING. Angle and Channel. Plain and Perforated Sheet. Willard Radchit, Fostoria, Ohio.

RECORDS—25-50% DISCOUNT on guaranteed factory fresh LP records; LP records 69c and up; pre-recorded tape. Send 20c for complete LP catalogue. SOUTHWEST RECORDS, 4710 Caroline, Houston 4, Texas.

TELEVISION RECEIVERS \$30 UP. W4APL 1420 South Randolph, Arlington 4, Virginia.

TV FM ANTENNAS, ALL TYPES INCLUDING UHF. Mounts, accessories. Lowest prices. Wholesale Supply Co., Lunenburg 2, Mass.

Get This Valuable Book

Just for Examining COYNE'S New 6-Volume Set

FREE

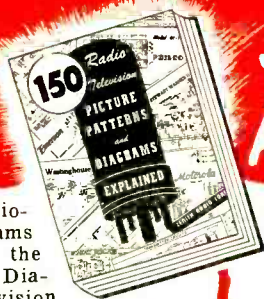

"Applied Practical Radio-Television"

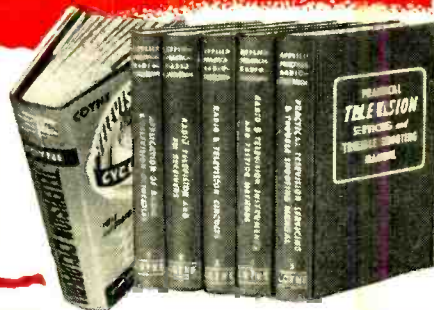

Yes, you get this big, new 1954 book, "150 Radio-Television Picture Patterns and Diagrams Explained", absolutely FREE! Just off the press! Gives complete 11x22" Schematic Diagrams on leading models Radio and Television Sets. Easy-to-read, large 8½x11" pages, with full instructions on how to read and use the diagrams. A "must" in every Radio and Television service-man's repair kit. You get this valuable book as a FREE Gift for asking to see Coyne's great new 6-book set, "Applied Practical Radio-Television"!

ON **7 DAY FREE TRIAL!**

At Last! Money-Making "Know-How" on Transistors, Color TV and Servicing

Coyne's great new 6-volume set gives you all the answers to servicing problems—quickly! For basic "know-how" that is easy to understand, you'll find everything you want in volumes 1 to 5 which contain over 5000 practical facts and data. They cover every step from principles to installing, servicing, trouble-shooting and aligning all types of radio and TV sets. So up-to-date it includes COLOR TV and UHF adapters, converters. Also covers latest data on TRANSISTORS.

Extra! 802-Page Television Cyclopedic Included

And then, for speedy on-the-job use, you get volume 6—the famous Coyne TELEVISION CYCLOPEDIA. It answers today's television problems on servicing, alignment, installation and others. In easy-to-find ABC order, cross indexed. Use this 6 volume TV-RADIO LIBRARY free for 7 days; get the valuable Servicing Book ABSOLUTELY FREE!

FREE BOOK—FREE TRIAL COUPON!

COYNE ELECTRICAL & TELEVISION-RADIO SCHOOL, Dept. A4-T1 500 S. Paulina St., Chicago 12, Ill.

YES! Send 6-volume "Applied Practical Radio-Television" for 7 days FREE TRIAL per your offer. Include TV-Radio Patterns & Diagram Book FREE.

Name _____ Age _____

Address _____

City _____ Zone _____ State _____

Where Employed _____

() Check here if you want library sent COD. You pay postman \$20.95 plus COD postage on delivery. 7-day money-back guarantee.

COYNE

ELECTRICAL & TELEVISION-RADIO SCHOOL
500 S. Paulina St., Dept. A4-T1 Chicago 12, Ill.

It will pay you to get to know the Gernsback Library Books

Check the books on this shiny red GERNSBACK LIBRARY rack at your parts distributor. You'll be amazed at the helpful information they offer at these low prices.



The Oscilloscope — No. 52. How to use the scope to best advantage in servicing. 192 Pages. \$2.25.

Transistors—theory and practice—No. 51. Rufus Turner explains transistors for the benefit of the practical man. \$2.00

TV Repair Techniques—No. 50. The experts tell you how to solve tough servicing problems. \$1.50

Radio & TV Test Instruments — No. 49. Build your own servicing instruments. \$1.50

High-Fidelity — Design, Construction, Measurements. No. 48. New 3-way approach by 21 top hi-fi experts. \$1.50

Radio & TV Hints—No. 47. Over 300 sure-fire hints, gimmicks, and short cuts. \$1.00

Television Technotes — No. 46. How to save trouble-shooting time. \$1.50

Radio Tube Fundamentals—No. 45. Theory for the practical man. \$1.00

Basic Radio Course — No. 44. John T. Frye gives the technician the low-down on theory. Cloth bound \$2.25.

Model Control By Radio —No. 43. Theory and construction for beginner and expert alike. \$1.00

High-Fidelity Techniques —No. 42. James R. Langham's off-beat classic for hi-fi fans. \$1.00

Public-Address Guide—No. 41. Only 75c
Practical Disc Recording—No. 39. Only 75c

Gernsback Publications, Inc. 25 W. Broadway, New York 7, N.Y. Publishers of RADIO-ELECTRONICS

DON'T YANK OR INSTALL A FLYBACK OR YOKE—TILL YOU CHECK IT WITH THE 944!

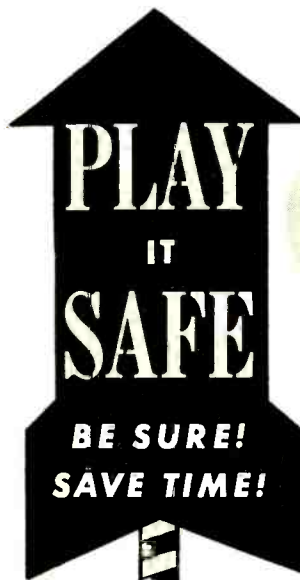

NEW! EICO 944 FLYBACK TRANSFORMER & YOKE TESTER KIT \$23.95. WIRED \$34.95.

A time—and trouble-saving MUST for TV servicemen!

- Positive check of all flybacks & yokes, in or out of set—fast!
- Uses sensitive grid-dip principle—detects even 1 shorted turn!
- Exclusive separate calibration for air- & iron-core flybacks assures utmost accuracy.
- Checks any inductance of not too low impedance; also usable for general continuity testing.
- Large 4½" 50 ua meter, 3 separate "Good-Bad" scales.



BUY EICO—at your local jobber—ard SAVE 50%. Write now for FREE Catalog CF-10

ELECTRONIC INSTRUMENT CO., Inc. 84 Withers Street • Brooklyn 11, N. Y.

**IT'S LIKE \$\$\$ IN YOUR POCKET
WHEN YOU HAVE OUR BIG 1955
FREE CATALOG!**

**164 VALUE-LOADED PAGES OF EVERYTHING
IN RADIO, TELEVISION AND ELECTRONICS**

**FOR 28 YEARS
THE OUTSTANDING
DOLLAR-SAVING
BUYING GUIDE
IN THE ENTIRE
ELECTRONICS
INDUSTRY!**

BURSTEIN-APPLEBEE CO.

**BURSTEIN-APPLEBEE CO. Dept. 5,
1012-14 McGee St., Kansas City 6, Mo.**

Send Free B-A Catalog No. 551.

Name.....
Address.....
City..... State.....

for
DEALERS
SERVICEMEN
SCHOOLS
CHURCHES
THEATRES
HOTELS
PUBLIC UTILITIES
EXPERIMENTERS
FACTORIES
ENGINEERS
LABORATORIES
AMATEURS

BURSTEIN-APPLEBEE CO. 1012-14 MCGEE ST., KANSAS CITY, MO.

SEND FOR IT TODAY!

**"If you want me to win
this election, you'd better
get a JENSEN NEEDLE."**

**DON'T
THROW
OLD
RADIOS
AWAY!**

**Here's the data you need
to fix them FAST and r-i-g-h-t!**

There's a "secret" to repairing old radios fast and profitably... and this big **RADIO TROUBLESHOOTER'S HANDBOOK** is it!

Just look up the old make and model you want to fix. This manual-size, 3 1/2 pound, 744-page Ghirardi handbook tells what the trouble is likely to be... and shows you exactly how to fix it. No useless testing! No wasted time! Even beginners can handle jobs "slick as a whistle."

THE ONLY GUIDE OF ITS KIND!
Eliminates testing . . . Cuts time in half!

Included are common trouble symptoms and their remedies for over 4,800 models of home and auto radios and record changers. Actual case histories cover practically every model made by 202 manufacturers between 1925 and 1942—Arling, Apex, Arvin, Atwater Kent, Belmont, Bosch, Brunswick, Clarion, Crosley, Emerson, Fada, G-E, Kolster, Majestic, Motorola, Philco, Pilot, RCA, Silver-tone, Spang, Sionberg, and dozens more. Gives how-to-do-it data on **SPECIFIC** jobs—**NOT** general theory. Includes hundreds of pages of invaluable tube and component data, service short cuts, etc.

...TRY IT 10 DAYS . . . at our risk!

Dept. RE-104 RINEHART & CO., Inc.
232 Madison Ave., New York 16, N. Y.

Send Ghirardi's **RADIO TROUBLESHOOTER'S HANDBOOK** for 10-day free examination. If I decide to keep book, I will then remit the full price of only \$6.50 plus a few cents postage. Otherwise, I will return book postpaid and owe you nothing.

NAME.....
ADDRESS.....
CITY, ZONE, STATE.....

Fig. 2 shows a typical variation of capacitance with voltage across the capacitor. Used in a TV sweep generator, a sawtooth waveform applied across the capacitor plates swept the frequency between 60 and 80 mc.

HIGH-VOLTAGE GENERATOR

Patent No. 2,680,830

Peter G. Sulzer, Kensington, Md.

(assigned to United States of America as represented by the Secretary of Commerce)

The circuit in Fig. 1 provides voltages higher than obtained from previous oscillator-type high-voltage d.c. generators. It uses a series-tuned grounded-plate Colpitts (Clapp) circuit that differs from the conventional Colpitts in that capacitor C1 is added in series with tank coil L1. The self-capacitance of L1 is reduced by C1, permitting use of a larger inductance and higher Q. The voltage generated is proportional to the Q.

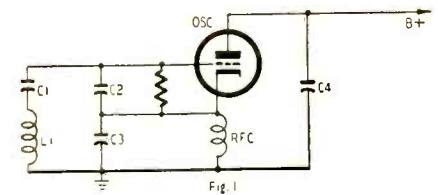
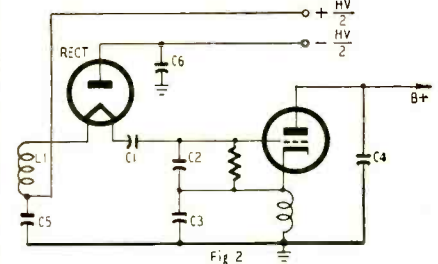

Fig. 2 shows a high-frequency generator used to develop both positive and negative voltages. The oscillator tank circuit provides filament current for the rectifier connected in series with it. Capacitors C5 and C6 are added for filtering and storage. When the r.f. voltage makes the rectifier filament negative with respect to the plate, the diode conducts and current flows through the circuit so the upper plate of C6 is charged negative and the upper plate of C5 is positive with



respect to ground. The rectifier does not conduct when its cathode is positive with respect to its plate. The total voltage developed is approximately equal to the peak negative swing of the oscillatory voltage. The negative and positive voltages are equal when C5 and C6 are equal.

A positive voltage equal to the sum of the negative and positive voltages can be obtained by grounding the rectifier plate. A negative voltage of equal value can be obtained by grounding the lower end of L1.

END

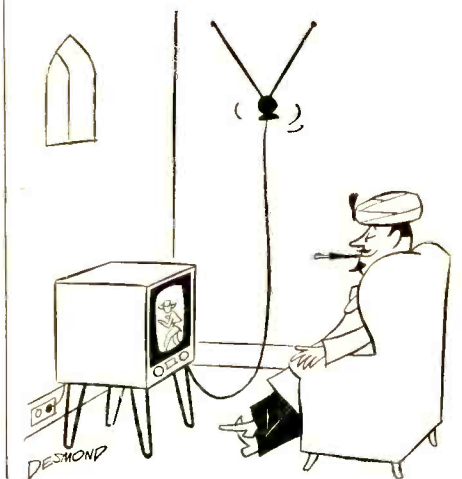



Measures 6 1/4" x 9 1/2" x 4 1/2"

Superior's new
Model 670-A

SUPER METER

A COMBINATION VOLT-OHM MILLIAMMETER PLUS
CAPACITY REACTANCE INDUCTANCE AND DECIBEL MEASUREMENTS

SPECIFICATIONS:

- D.C. VOLTS: 0 to 7.5/15/75/150/750/1,500/7,500 Volts
- A.C. VOLTS: 0 to 15/30/150/300/1,500/3,000 Volts
- OUTPUT VOLTS: 0 to 15/30/150/300/1,500/3,000 Volts
- D.C. CURRENT: 0 to 1.5/15/150 Ma. 0 to 1.5/15 Amperes
- RESISTANCE: 0 to 1,000/100,000 Ohms 0 to 10 Megohms
- CAPACITY: .001 to 1 Mfd. 1 to 50 Mfd. (Good-Bad scale for checking quality of electrolytic condensers.)
- REACTANCE: 50 to 2,500 Ohms 2,500 Ohms to 2.5 Megohms
- INDUCTANCE: .15 to 7 Henrys 7 to 7,000 Henrys
- DECIBELS: -6 to +18 +14 to +38 +34 to +58

ADDED FEATURE:

Built-in ISOLATION TRANSFORMER
reduces possibility of burning out
meter through misuse.

The Model 670-A comes housed, in a rugged crackle-finished steel cabinet complete with test leads and operating instructions.

\$28.40
NET



Superior's new
Model TV-11

TUBE TESTER

SPECIFICATIONS:

- ★ Tests all tubes including 4, 5, 6, 7, Octal, Lock-in, Peanut, Bantam, Hearing Aid, Thyatron Miniatures, Sub-miniatures, Novals, Sub-minars, Proximity fuse types, etc.
- ★ Uses the new self-cleaning Lever Action Switches for individual element testing. Because all elements are numbered according to pin-number in the RMA base numbering system, the user can instantly identify which element is under test. Tubes having tapped filaments and tubes with filaments terminating in more than one pin are truly tested with the Model TV-11 as any of the pins may be placed in the neutral position when necessary.
- ★ The Model TV-11 does not use any combination type sockets. Instead individual sockets are used for each type of tube. Thus it is impossible

to damage a tube by inserting it in the wrong socket.

- ★ Free-moving built-in roll chart provides complete data for all tubes.
- ★ Newly designed Line Voltage Control compensates for variation of any Line Voltage between 105 Volts and 130 Volts.
- ★ NOISE TEST: Phono-jack on front panel for plugging in either phones or external amplifier will detect microphonic tubes or noise due to faulty elements and loose internal connections.

The model TV-11 operates on 105-130 Volt 60 Cycles A.C. Comes housed in a beautiful hand-rubbed oak cabinet complete with portable cover

EXTRA SERVICE—The Model TV-11 may be used as an extremely sensitive Condenser Leakage Checker. A relaxation

type oscillator incorporated in this model will detect leakages even when the frequency is one per minute.

\$47.50
NET



SUPERIOR'S NEW MODEL TV-40

C.R.T. TUBE TESTER

A complete picture tube tester
★ for little more than the price
of a "make-shift" adapter!!

★ Tests all magnetically deflected
tubes . . . in the set . . . out
of the set . . . in the carton!!

The Model TV-40 is absolutely complete! Self-contained, including built-in power supply, it tests picture tubes in the only practical way to efficiently test such tubes: that is by the use of a separate instrument which is designed exclusively to test the ever increasing number of picture tubes!

EASY TO USE:

Simply insert line cord into any 110 volt A.C. outlet, then attach tester socket to tube base (*Don't Trap Need Not Be on Tube*). Throw switch up for quality test . . . read direct on Good-Bad scale. Throw switch down for all leakage tests.

SPECIFICATIONS:

- Tests ALL magnetically deflected picture tubes from 7 inch to 30 inch types.
- Tests for quality by the well established emission method. All readings on "Good-Bad" scale.
- Tests for inter-element shorts and leakages up to 5 megohms.
- Test for open elements.

Model TV-40 C.R.T. Tube Tester comes absolutely complete—nothing else to buy. Housed in round cornered, molded bakelite case. Only.....

\$15.85
NET

**SHIPPED ON APPROVAL
NO MONEY WITH ORDER — NO C.O.D.**

Try any of the above instruments for 10 days before you buy. If completely satisfied then send down payment and pay balance as indicated on coupon. No Interest or Carrying Charges Added! If not completely satisfied return unit to us, no explanation necessary.

MOSS ELECTRONIC DISTRIBUTING CO., INC.
Dept. D-66 3849 Tenth Ave., New York 34, N. Y.

Please send me the units checked. I agree to pay down payment within 10 days and to pay the monthly balance as shown. It is understood there will be no carrying, interest or any other charges, provided I send my monthly payments when due. It is further understood that should I fail to make payment when due, the full unpaid balance shall become immediately due and payable.

Model 670-A..... Total Price \$28.40
 \$7.40 within 10 days. Balance \$3.50
 monthly for 6 months.

Model TV-11..... Total Price \$47.50
 \$11.50 within 10 days. Balance \$6.00
 monthly for 6 months.

Model TV-40..... Total Price \$15.85
 \$3.85 within 10 days. Balance \$4.00
 monthly for 3 months.

Name

Address

City..... Zone..... State.....

EDLIE
says

Newest Flashlight
BROW-LITE
Frees Both Hands for repair work.



"BIG SAVINGS FOR YOU"

Just out! Brow-Lite gives you the third-hand you've always wished for when using a flashlight. Indispensable to servicemen—excellent for night work. Safer and quicker than flashlight. Fits easily on your head like a pair of glasses yet can be worn comfortably with or without glasses. Adjustable to any angle.

Complete with btry. & bulb
\$1.98

WORLD'S MOST USEFUL FLASHLIGHT. Uses standard penlite batteries & bulb.

Just Out! First Time Anywhere—
Larrel's **E-Z TV REPAIR GUIDE**

The only Fix-It-Yourself guide made expressly for YOUR TV SET!
Save costly TV repairs with this new, simplified method which includes all necessary data for just your set. No confusing, unimportant information applicable to hundreds of different makes. Simplifies detection of faulty tubes in your TV receiver. It's a great idea—it's a great guide! Order today and have your set back in perfect condition at once. Send us make and model of your set when ordering. Only **50¢**

E-Z TV REPAIR GUIDE
save costly TV repairs... FIX IT YOURSELF
This simplified method of repairing your own TV set...
PREPARED EXPRESSLY FOR YOU SET
No confusing unimportant information applicable to hundreds of different makes.
50¢
This Guide Has Been Prepared Only For
Book No. 231 RCA MODEL 63015
Larrel Electronics Inc.

NEW KIT SUPERSENSITIVE 2 STATION INTERCOMMUNICATION SYSTEM—Kit \$12.95



This fine unit is suitable for use in home, office, factory, nursery, or sick room. So sensitive it will pick up baby's whimper. Operates from 115 V. AC/DC. Both stations housed in compact, hand-carried plastic cabinets 6" x 6" x 2 1/2". Requires only 2 wires to connect for quick installation. Complete with 50 ft. of twin conductor wire.

Factory Wired.....**\$16.95**

3 TUBE



PHONO AMPLIFIER NOT A KIT

An assembled unit ready for installation using tone and volume control and 6 ft. rubber cord. (less tubes).....**\$2.95**
Lowest Price!
With complete set of tubes.....**\$4.45**

Phono Oscillator NEW SAVINGS! NOT A KIT!

Wireless phono oscillator transmits recording for crystal pickups or voice from carbon mike through radio without wires. Can also be used as an intercom by using PM speaker or.....**\$2.95**
mike (less tubes).....**\$2.95**
With complete set of tubes.....**\$3.95**

Electronic CODE OSCILLATOR KIT

AC-DC or Battery Operated!
Kit #2—One of the most practical Code Practice Oscillators ever designed, yet one of the simplest to build and operate. Can be used with any number of headphones. Adjustable Pitch Control—Any type of headpiece can be used. No warmup time—ready to operate instantly. Simple and safe to operate. Operates anywhere—with AC or DC power, or from a 90 volt Miniature Battery.
Lean Blinker Code with flashing light. Blinker can be used as signaling device. International Morse Code included.
KIT EACH \$1.95 Assembled \$2.95

3-Way Portable RADIO KIT AC/DC Batteries



NEW, compact, lightweight portable radio kit with the very latest supersensitive superhet. circuit. Wonderful reception from either batteries, or 115 V. 50-60 cycle AC or DC. Includes all complete parts (except wire & solder) necessary to build a great sounding radio. Also includes circuit diagrams and simplified, complete step-by-step instruction folder which makes assembling easy. Housed in a beautifully finished, glossed Catalin cabinet in two delightful and distinctive colors: maroon, or all-aster (ivory). Size: 9 1/2" x 5 3/4" x 4 3/4". Includes tubes!.....**\$13.95**

BATTERY KIT: add.....\$2.59

TERRIFIC VALUE!

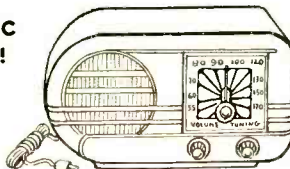

5 TUBE AC/DC Superhet Kit

Kit #1: 5 tube superhet kit. AC/DC includes all quality components required to construct this latest design, highly sensitive superhet broadcast receiver, complete with black, glistening bakelite cabinet (excludes wire & solder). Kit of 5 tubes. 12AT6, 2/12BA6, 12BE6, 35W4, 50B5.
Price, Less Tubes.....**\$7.95**
Extra for Tubes.....**\$3.25**

Great Savings!
6-TUBE RADIO KIT

Kit #2: Low priced 6-tube kit designed for extra high sensitivity, excellent selectivity and good, rich tone quality. Uses 251G, 25Z6, 68Q7, 68A7, 2/68K7 in an easily constructed circuit. Includes all parts, punched chassis, resistors, condensers, coils, sockets, PM speaker, hardware, etc. Special closeout price.....**\$6.95**
Matched set of 6 tubes for kit.....**\$3.25**

PRECISION WIRE WOUND RESISTOR KIT

Includes 20 resistors, WW3, WW4 and WW5 of 1% tolerance in assorted ohmages..... with plastic box.....**\$2.95**
SELENIUM RECTIFIERS
Standard high grade makes (Federal, Sarkes-Tarjian etc.) at great savings.
65 Ma.\$.54 | 300 Ma.\$1.19
100 Ma.\$.68 | 350 Ma.\$1.33
250 Ma.\$1.19 | 100 Ma.\$1.52
DEDUCT 10% on orders of 25 or more —may be assorted.

PRECISION RESISTOR KIT

Consists of 50—1% Wilkor carbon resistors of 50 different ohmages, housed in a transparent plastic box. May be combined in series or parallel to produce almost any desired ohmage. Each resistor retails for about .85c.
Terrific Cash Saver!
Kit of 50.....only **\$2.45**

Special Savings CRYSTAL DIODES

IN31.....\$.59 | IN48.....\$.45
IN34A.....\$.65 | IN64.....\$.45
IN47W.E.....\$ 1.25

TERMS: All mid-se shipped FOB New York City, prices subject to change without notice. Include 20% deposit for COD'S. WRITE TODAY FOR NEW FREE CATALOG!

Technicians' News

FRSAP INVESTIGATES

An investigation of tinkers—back-alley operators who ignore city, state, and federal taxes and business licenses—and employed technicians who do part-time night and Sunday work was initiated by the Federation of Radio Servicemen's Associations of Pennsylvania at its July meeting. Mr. Charles Knoell of Philadelphia was appointed chairman of a committee to prepare for the federation the forms and outlines now being used successfully in Philadelphia for such investigation. Information on unethical organizations and users of bait advertisements will also be gathered in the same systematic way and will be used to prepare reports for local sales tax offices, business and income tax headquarters, Better Business Bureaus and other interested agencies.

The committee will also prepare and supply each group with copies of an anti-bait advertising ordinance for presentation to local municipalities for enactment.

Mr. Art Guild of Williamsport was appointed chairman of the federation's Educational Committee, with instructions to prepare an upgrading course on black-and-white and color servicing similar to the one sponsored by RETMA. When completed, it will be distributed to all federation groups who ask local educational authorities for cooperation in presenting the course in their localities.

The Luzerne County delegation was appointed a committee to complete a price rate schedule based on their association's survey in Wilkes-Barre. The committee is to prepare a set of forms for distribution to all chapters for local price rate surveys.

The delegates voted to accept into the federation the South Central Service Dealers Association of Pennsylvania.

FEDERAL LICENSES?

The possibility of requiring federal licenses for radio and TV technicians was explored by the National Electronic Technicians Service Dealers Associations (NETSDA) meeting in Philadelphia July 25. The following statement was issued:

"Since it is the duty of the Federal Communications Commission to supervise the use and service of devices which can cause interference with radio communication in interstate and international service, which embraces AM, FM, and TV due to their network connections, we believe that a license should be issued by the FCC to all

EDLIE Electronics

154 Greenwich St.
DI 9-3143
New York 6, N. Y.

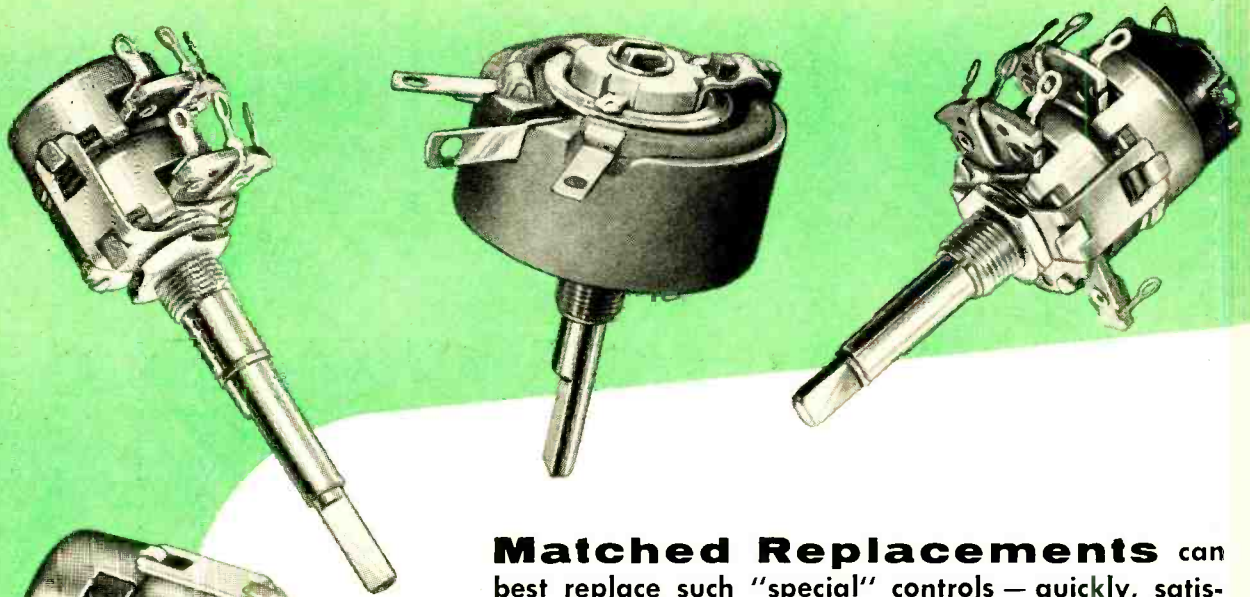

Matched Replacements can best replace such "special" controls — quickly, satisfactorily, economically. And that spells Clarostat's

RTV PROGRAM

The RTV Program available to you, means up-to-date, dependable, time-saving data in selecting the correct replacement control every time. It means getting a control that slips in place without fuss. It means an installation that matches the original. All in all, it means that you can handle **more service work** in **less time** and at **greater profit**, thanks to Clarostat's RTV Program.

Ask Your Distributor...

Let him tell you the details of Clarostat's RTV Program. Ask for the TV Manual and Supplements containing up-to-date replacement listings. And take advantage of your distributor's complete stock of RTV numbers for your most profitable service work.

CLAROSTAT



Controls and Resistors

CLAROSTAT MFG. CO., INC., DOVER, NEW HAMPSHIRE
In Canada: CANADIAN MARCONI CO., LTD., Toronto, Ont.

*W9WJV beats
last year's
Field Day record
with hallicrafters*



Lawrence T. Fadner, team captain in Chicago's 1954 North Suburban Ham Club ARRL 40 meter CW Field Day bettered the club's last year record by nearly 30%.



and Hallicrafters SX88 is hot news too. More hams are telling each other about this new receiver than about any equipment in years.

*Used by 33 governments,
sold in 89 countries*

hallicrafters
CHICAGO 24, ILLINOIS



MAIL THIS COUPON

FREE—Send me World-wide Time Conversion Dial Calculator and all band frequency allocation chart plus a fund of other handy data.

Name _____

Address _____

City _____ State _____

Ham (call letters _____) Listener

Occupation _____

Hallicrafters equipment I would like to know about: _____

qualified service technicians to help enforce the regulations.

"There are millions of TV receivers which can be used for jamming Conelrad civil defense emergency signals and do at present interfere with AM reception to such an extent that the public is forced in many cases to purchase FM receivers, leaving them without benefit and protection of the Conelrad service.

"There are also many cases of interference by electronic devices which could be corrected by qualified licensed technicians, directly resulting in benefit to broadcasters and the general public."

It was pointed out that there was some precedent for FCC licensing of service technicians, as at present technicians who service mobile and other equipment which includes transmitters, are obliged to have an FCC radio operator's license.

Further business of the meeting dealt with the establishment of a NETSDA bulletin and plans for an award to be issued annually to the manufacturer who produces the best equipment from the servicing viewpoint.

FINDS CARDS VALUABLE

The San Antonio RTA supplies its members with credential cards of the type shown here. These serve both to identify the repairman and to publicize the association. The state emblem (Texas Electronic Association) is also publicized in shop window decals and in TV advertising. Each spot features the names of two local associations, who share the cost of the spot.

**SAN ANTONIO RADIO & TELEVISION ASSN. INC.
THIS IS TO CERTIFY THAT**

Will Fixem

Having shown an interest in the advancement of Scientific Servicing of Radio and Television sets and of better public relations of the Electronic Industry is an ASSOCIATE MEMBER of the San Antonio Radio and Television Association, and in good standing for the year... 1954

Richard J. [Signature]
Secretary

ESFETA PLANS LECTURES

The Empire State Federation of Electronic Technicians Associations plans a series of lectures to start early in the fall and to rotate in four areas of New York State. The lectures will be held on Sundays. At present, one lecture per month in each area through the winter is planned.

The federation reports a new member, the Radio-Television Service Association of Western New York, with headquarters in Buffalo.

NATESA CONVENES

The fifth annual convention of the National Alliance of Television and Electronic Service Associations is being held September 24, 25 and 26 in the Morrison Hotel, Chicago.

A service technicians' show is being held in connection with the convention. RADIO-ELECTRONICS is present at Booth 37.

**NEW! ATLAS CJ-30
COBRA-JECTOR
INDESTRUCTIBLE FIBER-GLASS
ALL WEATHER
WIDE ANGLE DISPERSION**



List \$40.00
NET \$24.00
Complete with Driver.

Weatherproof Line Matching Transformer as shown, Net \$5.10.

New versatile all-purpose projector—excellent for paging & talk-back, intercom, marine, and industrial voice & music systems. Penetrating articulation assures wide angle intelligible coverage even under adverse sound conditions. "ALNICO-V-PLUS" magnetic assembly. Double-sealed against all weather. Omni-directional mounting bracket. Quick, easy installation. An amazing "power package"—Specify the CJ-30 for the "tough" jobs!

Input Power (continuous).....15 watts
Input Impedance.....8 ohms
Response250-9000 cps
Dispersion120° x 60°
Dimensions:Opening, 14" x 6"
Overall Length, 14"



**WRITE FOR COMPLETE CATALOG
ATLAS SOUND CORP.**

1443—39 St., Bklyn. 18, N. Y.
In Canada: Atlas Radio Corp., Ltd., Toronto, Ont.

**SHORT CUT to
Television Repairs!**

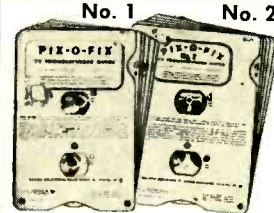

Eliminate useless testing . . . Fix sets in half the usual time

**PIX-O-FIX
TV TROUBLE-FINDER GUIDES**
By Ghirardi & Middleton
Only \$2 for the two

Just turn the dial of the handy, pocket-size Ghirardi & Middleton PIX-O-FIX TV Trouble Finder Guide. When the picture in the PIX-O-FIX window matches the screen image on the television set

you're repairing . . . presto! . . . you've got your clue.

PIX-O-FIX then shows the causes of the trouble. Next it indicates the exact receiver section in which the trouble has probably happened. Then it gives step by step repair instructions. Usually it even specifies the component likely to be at fault.

QUICK . . . EASY . . . ACCURATE

The two PIX-O-FIX units No. 1 and No. 2 cover 47 different television troubles . . . Just about anything you're likely to be called on to fix. No. 1 identifies 24 of the most common troubles and gives 192 causes and 253 remedies for them. No. 2 covers 23 more advanced troubles not included in No. 1. Together, they are a comprehensive guide to quick "picture analysis" servicing of any TV set . . . AND THE PRICE IS ONLY \$2.00 for the two. Money refunded if you are not more than satisfied. Just write your name and address in margin, enclose \$2.00 and mail to:

Dept. RE-104, RINEHART & COMPANY, Inc.,
232 Madison Ave., New York 16, N.Y.

RADIO-ELECTRONICS

new Tubes & Transistors

THE development of a new 21-inch tricolor picture tube has been announced by RCA. It has a useful viewing area of 250 square inches.

Features claimed for this tube include: the largest picture area now available; a new electron gun permitting a relatively short-length tube; lighter weight due to its metal construction; better color purity through an improved shadow mask and mounting system, and better picture contrast as a result of the new gun and shadow mask assembly, allowing the tube to be driven harder than was previously possible.

CBS-Hytron has announced the



The GC-10D cold cathode counting tube. Recording and counting is simplified by etched numbers on bezel.

21ZP4B, a magnetically focused and magnetically deflected aluminized picture tube. It is of all-glass rectangular construction and has a gray-glass spherical face plate. The tube has an outer conductive coating, which when grounded serves as a 500- μ f high-voltage filter capacitor. The 21ZP4B uses a single-field external ion-trap magnet and a deflection angle of 70°.

RCA announced seven new tube types that can operate with their heaters connected in a single, series circuit. These tubes correspond mechanically and electrically to standard units except in the design of their heaters, which have the same warm-up time to minimize voltage unbalance during starting. Drawing 600 ma, the tubes can be connected in series with a TV picture tube.

The seven tubes include: the 3BC5, a sharp-cutoff pentode for r.f. or i.f. amplifier use. It is a 7-pin miniature type, with a 3.15-volt heater, and corresponds to the 6BC5.

200 POUNDS on a 10 foot television mast PERMA-TUBE supports it safely!

Place a 10 foot length of 1¼" x 16 gage (.065") wall Perma-Tube between two tables so that 6 inches rests on a table at each end. Place a 200 pound weight at the center point.

What happens? Tests prove that Perma-Tube will support this 200 pound weight with a minimum of deflection and permanent set.

Other materials show serious degrees of permanent set. Why? Because they are not made from the special strength J&L steel that is used to form Perma-Tube Television Masts. And too, Perma-Tube is coated with a metallic vinyl resin—inside and out.

What do the strength and corrosion-resistance of Perma-Tube mean to you? They mean protection for your work and your customers. Freedom from damage due to storms . . . better reception from the sets you install . . . insurance for your reputation . . . increased business and profits for you.

Only GENUINE Perma-Tube supports 200 pounds with a minimum of permanent set . . . accept no claims from substitute materials. Look for this Perma-Tube Brand.

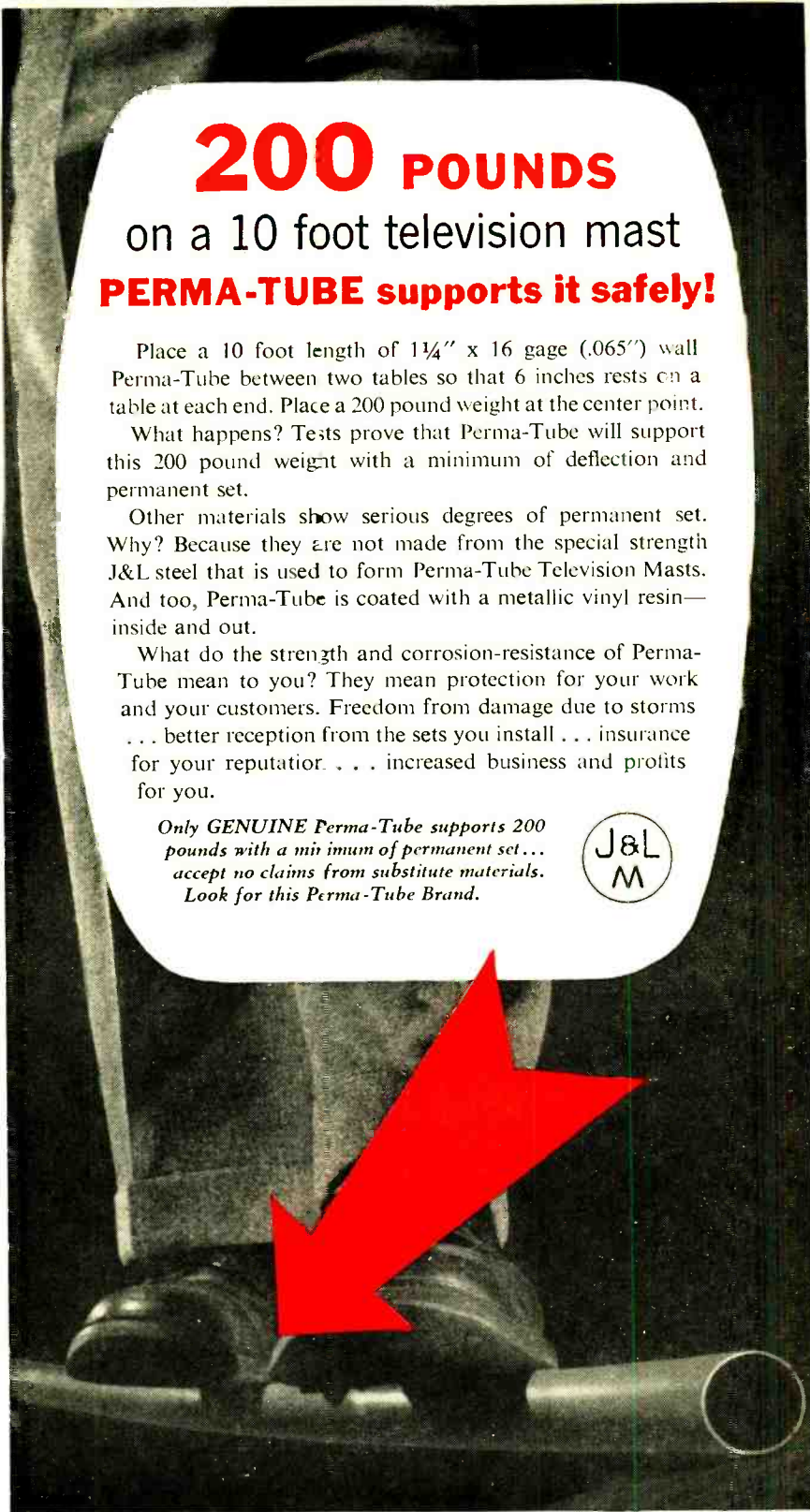

Make this test yourself. Compare Perma-Tube with any other masts—steel or aluminum.



Jones & Laughlin
STEEL CORPORATION — Pittsburgh

*Sold in 89 countries
used by 33 governments*



hallicrafters Chicago 24,
Illinois

From New Zealand to
Norway, from Formosa to Nigeria,
wherever world wide all band
reception is essential you will
find Hallicrafters receivers as
exemplified by the new Hallicrafters
SX88, the most talked about
receiver in years for amateurs,
industrials and governments.

The 3CB6, a sharp-cutoff pentode for use as an i.f. amplifier up to about 45 mc, and as an r.f. amplifier in v.h.f. television tuners. A 7-pin miniature type, it has a 3.15-volt heater, and corresponds to the 6CB6.

The 5AN8, a general-purpose medium-mu triode-sharp-cutoff pentode. The pentode section can be used as a video amplifier, a.g.c. amplifier, and reactance tube. The triode section is designed for use in low-frequency oscillator, sync separator, sync clipper, and phase splitter circuits. It is a 9-pin miniature type, with a 4.7-volt heater, and corresponds to the 6AN8.

The 5AT8, a triode-pentode converter designed for use as a combined oscillator and mixer in TV receivers using an i.f. of about 40 mc. A 9-pin miniature type, with a 4.7-volt heater, it corresponds to the 6AT8.

The 5J6, a medium-mu twin triode for use as an oscillator, r.f. amplifier, or as a mixer tube in v.h.f. TV tuners. It is a 7-pin miniature type, with a 4.7-volt heater, and corresponds to the 6J6.

The 5U8, a medium-mu triode-sharp-cutoff pentode for use as a combined oscillator and mixer in v.h.f. TV tuners. A 9-pin miniature type, with a 4.7 volt heater, it corresponds to the 6U8.

The 12L6-GT, a beam power tube for use in the audio output stages of TV receivers. It is a glass-octal type, with a 12.6-volt heater, and corresponds to the 25L6-GT.

These 600 ma tubes are part of a group of 36 scheduled for production by the TV industry. Tung-Sol has recently released 26 of these. Other manufacturers are also in production on this series.

Sylvania has announced two new aluminized picture tubes, the 17QP4A and the 27SP4.

The 17QP4A is an all-glass rectangular tube with a gray filter cylindrical face. It is magnetically deflected and focused, uses a single-field ion-trap magnet, and contains an external conductive coating. The deflection angle of 70° permits an over-all tube length of only 19 3/16 inches. The total picture area is approximately 149 square inches.

The 27SP4 is an all-glass rectangular tube with a gray filter spherical face. It is magnetically deflected and focused, uses a single-field ion-trap magnet, and has an external conductive coating. The deflection angle is 90°, giving it an over-all length of 23 1/16 inches. The total picture area is approximately 425 square inches.

Another RCA announcement this month concerns the 6524, a twin beam power tube. It is designed for use as a push-pull r.f. power amplifier or as a frequency tripler in fixed and mobile equipment operating in the u.h.f. range between 450-470 mc. It is also useful as an a.f. power amplifier and modulator.

This tube will be particularly useful to those radio amateurs operating in the 420-450-mc band as well as in the lower-frequency bands.

**Preferred for
Original Equipment
Proven for
Replacement**

**O
X
F
O
R
D**

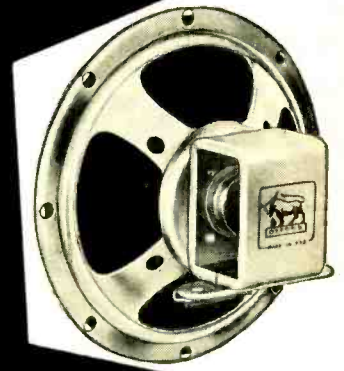

Speakers

Available from leading jobbers!

OXFORD ELECTRIC CORP.

3911 S. Michigan Ave., Chicago 15, Ill.

EXPORT: ROBURN AGENCIES, N.Y.C., N.Y.

In Canada: Atlas Radio Corp., Ltd., Toronto



Lincoln Color Bar Generator

Crystal controlled R.F. generator produces a fully encoded color TV signal for checking operation of color receivers, color killers, chrominance channels, color purity, etc. Precision engineered for servicemen, distributors, research engineers, technicians. Makes all primary colors for adjustment of HUE, CHROMA. Covers all channels 2-13. Self-calibrating. No auxiliary equipment required. Simple to operate, full instructions.

Send coupon now - Money Back Guarantee

Check or Money Order
Positively No C.O.D.'s

Lincoln Rec., Inc. 84 Merrick Rd. Amityville, N. Y.

Lincoln Rec., Inc.
84 Merrick Rd.
Amityville, N. Y.

Please send _____ Generators at \$29.95 to:

NAME _____
ADDRESS _____
CITY _____ ZONE _____ STATE _____

The 6524 has a maximum plate dissipation rating of 25 watts under ICAS conditions. Under these conditions in class-C telegraphy and frequency-modulated service at 462 mc, the 6524 can deliver approximately 20 watts.

The 6463, a new miniature twin triode whose higher permeance and plate current will allow the design of electronic computers faster than many in current use, has been announced by G-E. This tube will take over jobs previously assigned to the 12BH7.

Current ratings of the 6463 are ample for higher computer speeds. Its plate dissipation is 4 watts per unit and 7 watts total for the tube.

A new cold-cathode counting tube with a maximum input frequency of 20,000 counts per second is now available for use in fast registers and counters.

With this tube, model GC-10D, made by Tippet & Co., Inc., Boston, the count may be determined by noting the position of the glow on any one of the 10 radially spaced cathodes (see photo) around an axially positioned anode.

The tube can be reset with a push-button. A light shield and bezel with etched numbers indicate the glow position more conveniently for recording and counting. Low current drain permits use of an inexpensive power supply. The GC-10D operates on 420 volts d.c. The plate current is 800 microamperes.

CBS-Hytron has announced a new p-n-p power junction transistor. This device, known as the HD-197, is of germanium construction and is capable of 500 milliwatts collector dissipation. Because of its high current gain, the HD-197 transistor is suitable for switching circuits and servomechanisms.

Another CBS-Hytron announcement concerns the 27RP4, a spherical-face, rectangular, all-glass, aluminized picture tube. It is magnetically focused and magnetically deflected, and has an outer conductive coating that when grounded, serves as a 500- μ f high-voltage filter capacitor. The 27RP4 has a 90° deflection angle and operates with 16,000 volts on its anode under typical conditions. END

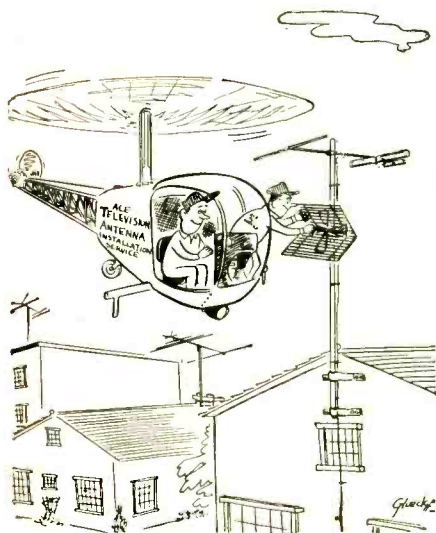

A. A. Ghirardi

J. R. Johnson



...here's how to LEARN SERVICING R-I-G-H-T!

Complete training in modern professional methods . . . only \$12 . . . 3 months to pay!

FIX ANY RADIO OR TV SET EVER MADE...easier...better...faster

Radio & TV Receiver TROUBLESHOOTING AND REPAIR

by Ghirardi & Johnson

822 pages, 417 illustrations
Price \$6.75

(See special offer in coupon)

This big, 822-page book brings you the kind of PROFESSIONAL training that helps you handle the toughest radio-television-electronic service jobs as slick and as accurately as you now do the easy ones!

For service beginners, Radio & Television Receiver TROUBLE-SHOOTING AND REPAIR is a complete, easily understood professional training course. For experienced servicemen, it is the ideal way to "brush up" on specific jobs; to develop better troubleshooting methods and shortcuts; and to find quick answers to puzzling service problems.

Step by step, it takes you through each service procedure . . . from locating troubles quicker and with less testing to repairing them faster and better.

You learn to deal with any kind of trouble in any kind of receiver. No guesswork. No aimless testing.

Here are just a few of the subjects covered: Components and Their Troubles; Basic Troubleshooting Methods; "Static" and "Dynamic" Testing; Practical Troubleshooting Tips and Ideas; AC/DC, 3-way Portable and Battery-set Problems; Servicing Communications Receivers; A Complete Guide to Television Service; AM, FM and TV Realignment Made Easy; Resistor, Capacitor, Inductor and Transformer Problems; Servicing Tuning, Selector and Switching Mechanisms; Loudspeakers; Servicing Recorders and Record-playing Equipment . . . and dozens more. Use coupon. Read it for 10 days at our risk.

LEARN BASIC CIRCUITS...and watch service "headaches" disappear!

Radio & TV Receiver CIRCUITRY AND OPERATION

by Ghirardi & Johnson

669 pages, 417 illustrations
Price \$6.50

(see special offer!)

It's amazing how much easier you can repair radio and television sets and even industrial electronic equipment when you know all about their circuits. You locate troubles in a jiffy because you know what to look for and where to look. You handle jobs lots faster, better . . . and more profitably.

Radio & Television Receiver CIRCUITRY AND OPERATION gives you a complete understanding of basic circuits as well as their varieties. It teaches you to recognize them . . . to understand their peculiarities . . . to

know their likely "troublespots" . . . and how to eliminate guesswork and useless testing.

Throughout, this new book brings you the kind of above-average professional training that fits you for the bigger, better-pay jobs. Covers all circuits used in modern television and radio receivers, amplifiers, phono pick-ups, record players, etc.

Price only \$6.50 . . . or see money-saving combination offer in coupon. 10-day FREE examination.

Save \$1.25!

Make your training library complete. Have ALL the latest data at your fingertips. Get both these books at only \$12.00 for the two . . . YOU SAVE \$1.25.

FREE EXAMINATION . . . easy terms!

Dept. RE-104, RINEHART & CO., INC.,
232 Madison Ave., New York 16, N.Y.

Send books indicated for FREE EXAMINATION. In 10 days, I will either remit price indicated plus a few cents postage or return books postpaid and owe you nothing.

Radio & TV CIRCUITRY AND OPERATION (Price \$6.50) Radio & TV TROUBLE-SHOOTING AND REPAIR (Price \$6.75)

COMBINATION OFFER . . . Both books only \$12.00 (Regular price separately \$13.25 . . . you save \$1.25) (Combination offer is payable at rate of \$3 (plus postage) after 10 days if you decide to keep books, and \$3 a month thereafter until \$12 has been paid.)

Name _____
Address _____
City, Zone, State _____

OUTSIDE U.S.A. . . . \$7.25 for TROUBLESHOOTING AND REPAIR; \$7.00 for CIRCUITRY AND OPERATION; \$13.00 for both books; Cash with order, but money refunded if you return books in 10 days.

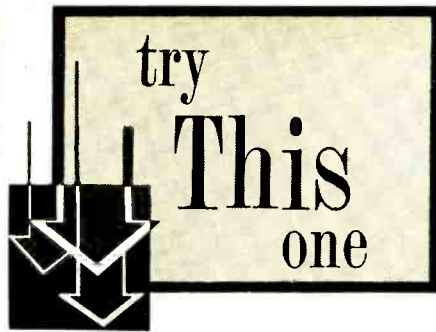
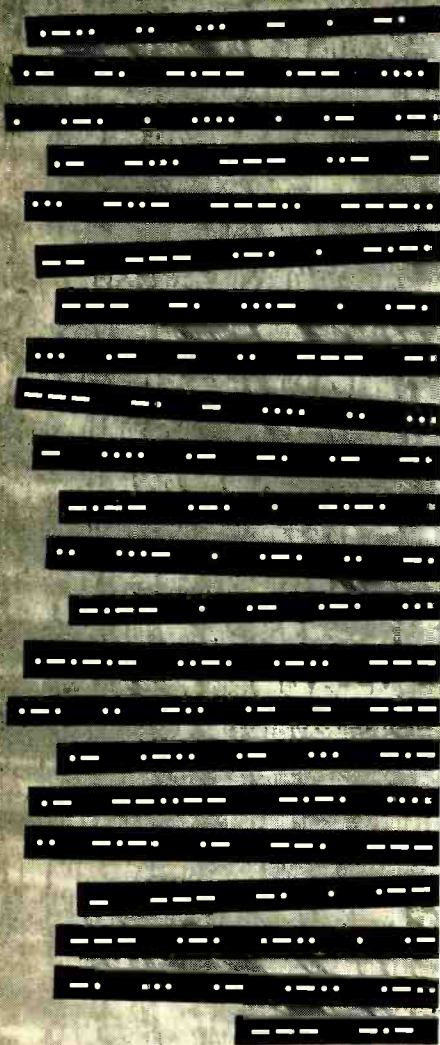

CODED TEST LEADS

Test leads with alligator clips are often used in temporary experimental hookups. Using several leads of the same color may lead to errors in complicated circuits.

To minimize errors and to make it easy to trace circuits, I use four pairs of special coded leads made up as follows: one set with red insulated clips on red insulated wire, one with red clips on black wire, one with black clips on red wire, and one with black clips on black wire.—*Charles E. Cohn*

HASN'T SCRATCHED YET

Finished panels on transmitters, amplifiers, and test instruments can be easily scratched or marred through careless use of a hex wrench or pliers when replacing or removing a rotary control or a switch. To prevent this, use a thin plastic sheet about 2 x 5 inches with a hole in one end just large enough to clear the nut. Slipped over the shaft, it prevents scratches that would be caused by contact between the tool and panel.—*Nicholas B. Cook*

LINE TEST ADAPTER

Measuring line voltage with test prods pushed into a wall receptacle is somewhat of a job. I made an adapter to simplify reading line voltage at receptacles.

Select a round bakelite-type flat-top line plug. Remove the terminal screws and select a drill just small enough to pass through the screw holes without damaging the threads. Use the screw holes as guides to drill carefully through the plastic cap. Replace the terminal screws to complete the adapter.

To use the adapter, plug into a receptacle, set your meter to the desired range, and then insert the prod tips into the holes in the cap.—*Allen J. Schwartz*

GREASE JOB

It has been suggested that you use a grease pencil to mark the edges of your work if you want to make a neat solder job on chassis or similar metalwork. The grease acts as a mask to keep the edges of the job straight and clean.

Grease pencils are not usually carried in the average tool kit and may be hard to find in an emergency. However, most of us have one available even if we don't recognize it. It is in your wife's bag. For a lipstick is a grease pencil.—*B. W. Welz*

MOST POWERFUL

27" WIRED CHASSIS
28 TUBES, including CRT



LIFESIZE PICTURE \$239.00
plus 10% Tax

Ideal for Custom Installations

This *De Luxe Transvision Chassis* is ideal for fringe area, UHF-VHF reception. . . . Has super-sensitivity and stability. . . . Keyed AGC . . . 28 tubes, including CRT and 3 rectifier tubes. Also available with Remote Control and dual sound system for \$69 additional. *Order today, direct from:*

TRANSVISION

THE OLDEST NAME IN TV KITS
Div. of Sigmastar Corp.
NEW ROCHELLE, N. Y.

TV GLO-TEST

Replaces \$279 in TESTING EQUIPMENT



This is the instrument that appeared in feature articles in RADIO-ELECTRONICS and other publications. GLO-TEST is the sensational new tester that almost talks! For TV and Radio servicemen, Sound Technicians, Amateurs, Experimenters, Electricians.

OVER 50 USES, INCLUDING—
PIXTUBE TESTER—AC-DC—VOLTAGE MEASUREMENTS TO 50 KV—SIGNAL GENERATOR—SIGNAL TRACER—TUBE TESTER—RESISTOR AND CAPACITOR MEASUREMENTS—DISTORTION AND LINEARITY CHECKER. ACCURACY COMPARABLE TO VTVM. FULLY GUARANTEED
Replaces instruments costing many times its cost, does a comparable job yet is only a small fraction of their total weight and size. GLO-TEST, complete with test leads and instruction booklet, postpaid, is priced at **\$14.50** at only **99¢** in advance. *Send check or money order. 10-day money back guarantee. Free literature on request.*

V. A. ENTERPRISES, Dept. AA
608 East Rosecrans Blvd., Compton, Calif.

OSCIL-O-PEN

Extremely convenient test oscillator for all radio servicing: alignment • Small as a pen • Self powered • Range from 700 cycles audio to over 600 megacycles r.f. • Output from zero to 125 μv • Low in cost • Used by Signal Corps. • Write for information.

GENERAL TEST EQUIPMENT
38 Argyle Ave. Buffalo 9, N. Y.

RADIO-ELECTRONICS

Hallicrafters

MAIL THIS COUPON

FREE—Send me World-wide Time Conversion Dial Calculator and all band frequency allocation chart plus a fund of other handy data.

Name _____

Address _____

City _____ State _____

Ham (call letters _____) Listener

Occupation _____

Hallicrafters equipment I would like to know about: _____



AUTO RADIO SUPPLY

The usual bench supply for servicing auto radios consists of a 6-volt battery eliminator with a storage battery across its output for additional filtering and to supply additional current to operate transmitters and some types of automatic receiver tuning mechanisms. When the eliminator is turned off, the

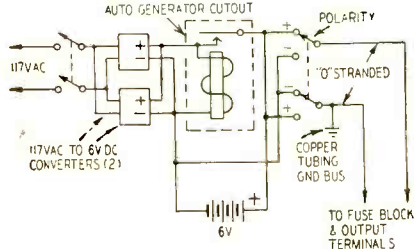

battery discharges through it unless disconnected. One way to prevent this is to connect the battery across the 6-volt d.c. line through the contacts of a 117-volt a.c. relay across the eliminator input.

Brad Trask of Eugene, Ore., describes a novel arrangement in *Motorola Newsgram*. The circuit of his service-bench supply is shown. The supply consists of two 6-volt A-battery eliminators connected in parallel. An automobile-type low-voltage cutout relay coil across the output automatically disconnects the eliminators from the load and battery when the line switch is open. Polarity is reversed with a heavy-duty d.p.d.t. switch. Leads are No. 0 strand cable.

TESTING TAPE HEADS

Here is a method of quickly testing tape recorders with separate erase, record, and playback heads:

1. Splice a length of tape into a loop.
2. Make sure that the heads are clean and free from bits of tape and brown smears.

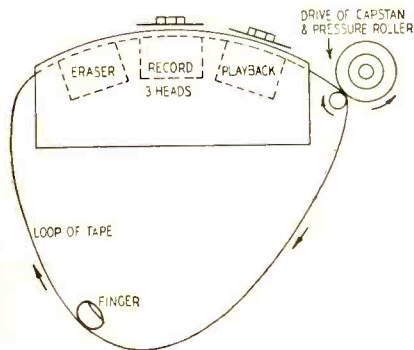

3. Place the tape over the heads and between the capstan and pressure rollers.

4. Apply a signal to the recording amplifier.

5. Start the tape rolling and gently press a finger to the inside of the tape so it runs evenly over the three heads as shown in the illustration.

6. Listen to the output signal in the playback amplifier. A weak or distorted signal indicates trouble that must be located by trouble-shooting.—N. H. Kent

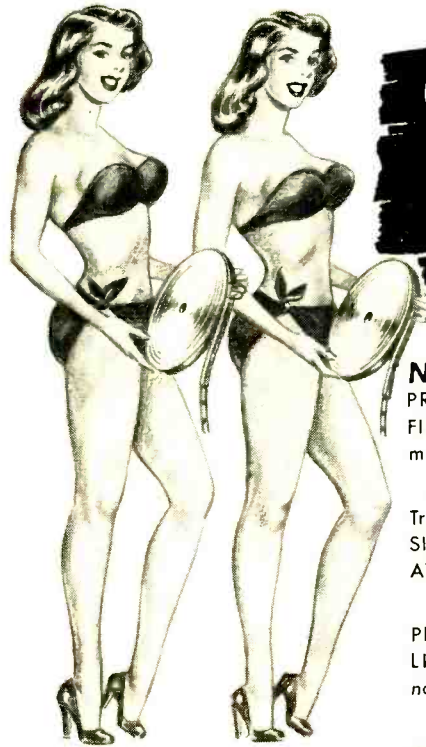

GOODLINE

is *Virgin*

POLYETHYLENE

Now—SILICONE "WETPRUF"® PROCESSED, ANOTHER GOODLINE FIRST, Extends useful wet service life as much as 400%.

ALL GOODLINE Low Loss Television Transmission Lines are now especially SILICONE PROCESSED to repel moisture AT NO INCREASE IN COST TO YOU.

Your distributor has these SILICONE PROCESSED, WATER REPELLENT GOODLINE TRANSMISSION LINES in stock now—ready for you...

Ask for them by name. Insist on these genuine GOODLINE "WETPRUF" TELEVISION LINES.

GOODLINE AIRLEAD — 733 GA & 737 GA GOODLINE HOLO — 801 GH
GOODLINE SHEATHLEED — 812 GS & 823 GS GOODLINE TELEAD

ALSO THE ECONOMY NON-SILICONE GOODLINE ANGELUS

* IT'S EASY TO TELL IF IT'S "GENUINE GOODLINE!" All Don Good Television Leadlines are Quickly Identified By The Blue and Yellow Reel.

ALL GOODLINE TELEVISION TRANSMISSION LINES ARE PURE VIRGIN POLYETHYLENE ESPECIALLY COMPOUNDED FOR LONG SERVICE LIFE.

Don Good, INC.

SOLD BY LEADING
JOBBER & DEALERS

Send coupon NOW!
Get samples "in your hands"
—you'll realize why
Don Good Products make
the finest television
reception possible.

DON GOOD, INC. 1-18
1014 Fair Oaks Ave., So. Pasadena, Calif.
Please rush Samples and Complete Information covering Don Good Products.

Name _____
Street _____
City _____ State _____

FASTER TROUBLE SHOOTING!

NEW TV DYNATRACER

THE 3-IN-1 TEST TOOL

REQUIRES NO ADDITIONAL EQUIPMENT
SIGNAL TRACER · VOLTAGE TRACER · COMPONENT CHECKER

SPECIFICATIONS—The self contained DYNATRACER isolates trouble to a stage or component . . . tracing signals through any Video, Sound Sync, ACF, Horizontal or Vertical Sweep Circuit.

WHAT'S MORE, this remarkable instrument traces voltages (50/500V AC/DC) and then instantly locates open, shorted, intermittent or leaky (up to 20 megohms) condensers, resistors, coils, transformers, etc.

Save Time—Save Labor—Save Money—With The DYNATRACER
—Your Most Indispensable TV Repair Tool—

Complete Trouble Shooting Manual Enclosed FREE

See your local distributor—or if he can't supply you clip a \$5.00 bill, check or money order to this advertisement. 100% absolute satisfaction guaranteed or money back within ten days.

Send Your Order Today to



\$4.95
POSTPAID

Century ELECTRONICS CO.
211-04 99th Ave., Dept. 118
Queens Village, N. Y.

10,000 Servicemen
Users of DYNATRACER
Can't Be Wrong!

Inventory

OF EQUIPMENT AT

Western Union Telegraph Co.
Development & Research Dept.
Electronics Research Div.
Water Mill, N. Y.

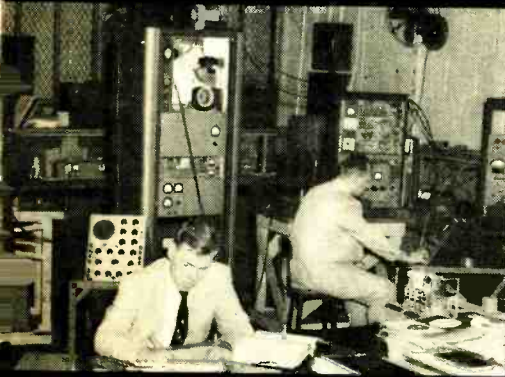

INCLUDES **13**
hallicrafters
RECEIVERS



HALLICRAFTERS SX88

Wherever world wide, all band radio reception is important and reliability of receiver performance paramount, there is bound to be **HALLICRAFTERS!** The radio man's radio.

*Used by 33 governments,
sold in 89 countries.*

hallicrafters

CHICAGO 24, ILLINOIS

FUSE INTERLOCK

The diagram shows how I rigged the high-voltage supply in the shop so its line fuses must be removed before the front panel can be taken off. This provides a positive safety interlock that removes all input power but permits power-on tests to be made by reinserting the fuses with the panel removed.

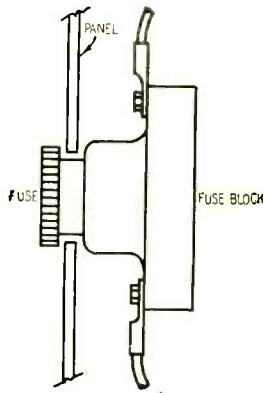

The fuse block is mounted directly behind the panel. The fuses project through holes just large enough to pass the threaded body without clearing the large end.

This setup permits quick and easy fuse changing, and also quickly indicates a blown fuse. The inconvenience of having to remove the fuse pays for itself in safety.—*Robert E. Riddle*

UNGAR PENCIL

In this column of the July, 1953, issue, A. Von Zook describes how he uses a heavy coil spring to prolong the life of tips in Ungar soldering pencils. I prevent cracking of the porcelain base and at the same time form a handy rest for the iron by slipping a broom hanger over the porcelain part of the tip as

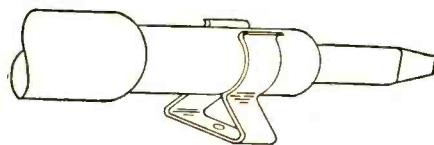

shown in the drawing. You can get these hangers at stores selling household hardware.—*Albert White*

FEEDBACK OSCILLATOR

The feedback-type code oscillator in the diagram is simple and requires a minimum of parts. The pitch is adjusted with the wing-nut that moves the

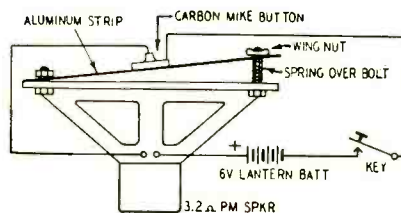

aluminum strip toward or away from the speaker. Feedback occurs between the speaker and mike button when the key is closed.—*Robert P. Kraig* END

GREYLOCK'S NEW HEADQUARTERS OPENING SPECIALS!

COMPLETE LINE OF STANDARD
BRAND TV AND RADIO PARTS
AND TUBES AT
LOWEST POSSIBLE PRICES

STANDARD BRAND DISTRIBUTORS
TUBES IN ORIGINAL BOXES.
ALL TYPES IN STOCK

LESS 50% and 10%

Cathode Ray Tubes — Dumont Licensed

12LP4	\$14.20	16R/KP4	\$17.40
14BP4	\$15.90	17BP4	\$18.60

20CP4

plus large allowances on your old tube. All tubes shipped prepaid to us.

SELENIUM RECTIFIERS

65 Mil.49	250 Mil.	1.19
100 Mil.75	300 Mil.	1.19
150 Mil.85	*350 Mil.	1.49
200 Mil.	1.19	400 Mil.	1.49
		*500 Mil.	1.69

*Available in either flat or aircooled, please specify. Boxed 5c ea. extra.

Federal Selenium Rectifiers, 75 Mil, Special . . . 49

5" PM speaker, 1 oz magnet	\$.99
Special 4-prong standard 6-volt non-synchronous vibrator, brand new, fresh stock	1.19
Lots of 12 Net	12.95

American crystal cartridge type CRIA, 3 volts output, individually boxed, replaces Astatic L type, and many other 78 RPM phono cartridges	1.59
Webster N10P6 cartridge for 78 RPM	1.79

TOP BRAND MFRS'. CLOSEOUT

Top Brand L82 Pickup and cartridge	2.59
MLP-1 crystal cartridge & pickup arm nylon cartridge and needle	1.95

3-Speed universal osmium phono needle, individually packaged. List price \$1.50—Special35
10 for	2.95

TUBULAR ELECTROLYTIC CONDENSERS

8 Mfd 450 volt25
8-8 mfd 450 volt35
20-20 mfd 150 volt29

300-OHM TWIN LEAD, 7 STRAND

55 Mil 22 gauge, per 1000 ft.	8.95
100 Mil 20 gauge, per 1000 ft.	13.95
100 Mil 20 gauge, Federal silver line, per 1000 ft.	16.95
Aluminum ground wire, #8.50 st., per 1000 ft.	9.95

All-channel 8-element conical antennas, Carbons of 12, each (Individually boxed, add 75c ea. extra)	2.49
Stacking bars for above, per pair50

Low-band folded dipole, quick-rig	2.99
High-band folded dipole, quick-rig75
Combination of above hi and lo dipoles	3.59

4-Element High Band Yagis Channels 7 thru 13, 1.69

Our new large quarters of over 15,000 sq. ft. enables us to service you promptly and efficiently.

We wish to take this opportunity to thank all our customers for their past patronage. All orders F.O.B. N.Y.C. No orders accepted under \$5.00 — 25% deposit required on C.O.D. orders

GREYLOCK ELECTRONICS SUPPLY COMPANY

554 West 168th St. (nr. Broadway)
New York 32, N. Y.
Phone TOmpkins 7-9050

Convenient to All Subways & Buses
Around Corner 168th St. Bus Terminal



The data that Launched
Thousands of Careers
is yours FREE to show

HOW YOU CAN BE SUCCESSFUL IN RADIO-TV-ELECTRONICS

Send for Your Booklet Today!

YOU CAN plod along for years, getting a paltry increase now and then, enjoying little security, finding your work dull and drab.

Then something happens. Things look up. You become more confident. Your earnings rise. You feel more important.

"Luck," some may say.

"Contacts," others may suggest.

But in your heart, you will know the answer: "Training." And it all may have started the moment you filled out a coupon requesting a copy of a free booklet named "Your Future in the New World of Electronics." From this data you get knowledge of where you stand in Electronics. Tremendous expansion leaves this gigantic industry pleading for trained men. Top manufacturers sold billions of dollars worth of electronic merchandise in 1953. By 1960, the radio-electronics industry should do no less than 10 billion dollars per year, not counting military orders.

Today there are over 97,000 radio-equipped police cars; an even larger number of taxis are radio equipped (at least 87,000); 32,000 civilian planes have radio; 35,000 American ships have radio.

Today there are over 120,000,000 radios in use. There are 28,000,000 TV sets and 381 TV stations in operation. Color TV is coming into its own. Countless positions must be filled—in development, research, design, production, testing and inspection, manufacture, broadcasting, telecasting and servicing. To fill these posts, trained men are needed—men who somewhere along the line take time to improve their knowledge, their skills. Men who, today, perhaps, take two minutes to send for a booklet.

"Your Future in the New World of Electronics" shows you how CREI Home Study leads the way to greater earnings through the inviting opportunities described above.

However, CREI does not promise you a "snap." With an accredited technical school such as this, you must *study* to convert your ambition into technical knowledge you can sell in the fabulous Electronics market.

Since its founding in 1927, CREI has provided thousands of professional radio men with technical educations. During World War II CREI trained thousands for the Armed Services. Leading firms

choose CREI courses for group training in electronics, at company expense, among them United Air Lines, Canadian Broadcasting Corporation, Trans-Canada Airlines, Sears, Roebuck and Co., Bendix Products Division, All-American Cables and Radio, Inc., and RCA Victor Division.

CREI courses are prepared by recognized experts, in a practical, easily understood manner. You get the benefit of time-tested materials, under the personal supervision of a CREI Staff Instructor, who *knows* and *teaches* you what industry wants. This is accomplished on your own time, during hours selected by you, and controlled by your own will power. This complete training is the reason that graduates find their CREI diplomas keys-to-success in Radio, TV and Electronics. CREI alumni hold top

positions in America's leading firms. At your service is the CREI Placement Bureau, which finds positions for advanced students and graduates. Although CREI does not guarantee jobs, requests for personnel far exceed current supply.

Now is the time of decision for you. Luck will not propel you forward unless it finds you trained. Contacts won't budge you an inch unless you have the skill to back them up. The answer is: Technical Training . . . and willingness to learn. Together they will bring you increased earnings in this new Age of Electronics. Fill out the coupon below and mail it now. We'll promptly send you your free copy of "Your Future in the New World of Electronics." The rest—your future—is up to you.

CREI resident instruction (day or night) is offered in Washington, D.C. New classes start once a month.
VETERANS: If you were discharged after June 27, 1950—let the new G.I. Bill of Rights help you obtain CREI resident instruction. Check the coupon for full information.

MAIL COUPON FOR FREE BOOKLET

CAPITOL RADIO ENGINEERING INSTITUTE

Accredited Technical Institute Curricula. Founded in 1927

Dept. 1410A, 3224 16th St., N.W., Washington 10, D. C.

Send booklet "Your Future in the New World of Electronics" and course outline.

CHECK Practical Radio Engineering Aeronautical Radio Engineering
FIELD OF Broadcast Radio Engineering (AM, FM, TV)
GREATEST Practical Television Engineering
INTEREST TV, FM & Advanced AM Servicing

Name

Street

City Zone State

Check Residence School Veteran

NEW STOCK OF FIRST QUALITY

TELTRON TUBES

GUARANTEED!... LOWEST PRICES EVER!

All tubes individually boxed... unconditionally guaranteed for one year!

GIFT OFFER!
One 6BG6G tube will be shipped FREE with any order accompanying this ad.

Type	Price	Type	Price	Type	Price	Type	Price	Type	Price	Type	Price
1A7GT	.53	5V4G	.49	6AT6	.37	6BN6	.90	6SA7GT	.45	12AU6	.43
1H5GT	.51	5Y3GT	.30	6AU5GT	.60	6BQ7	.85	6SK7GT	.45	12AU7	.58
1L4	.51	5Y4G	.40	6AV5GT	.60	6BY5G	.60	6SL7GT	.60	12AV6	.42
1L6	.51	5Z3	.42	6AV6	.37	6BZ7	.95	6SN7	.60	12AV7	.73
1LC6	.49	6A8	.40	6AX4GT	.60	6C4	.41	6SQ7GT	.38	12AX4GT	.60
1N5GT	.51	6K7	.40	6AX5GT	.60	6CB6	.51	6T8	.71	12AX7	.61
1R5	.51	6Q7	.40	6BA7	.58	6CD6G	1.63	6U8	.76	12AZ7	.65
1T4	.51	6AB4	.43	6BC5	.48	6CU6	.95	6V3	.60	12B4	.72
1U4	.51	6AC7	.65	6BE6	.46	6FF6	.42	6V6GT	.48	12BA6	.46
1U5	.43	6AF4	1.02	6BF5	.48	6FSGT	.44	6W6GT	.53	12BA7	.58
1X2	.65	6AG5	.52	6BF6	.48	6H6	.50	6X4	.37	12BE6	.46
2A3	.35	6AH4GT	.65	6BG6G	1.18	6J6	.61	6X5GT	.38	12BH7	.61
2A7	.35	6AJ5	.96	6BH6	.51	6J5GT	.49	6X8	.80	12BZ7	.63
3Q4	.53	6AK5	.96	6BJ6	.51	6K6GT	.39	7F7	.49	12K7	.40
3Q5GT	.61	6AL5	.43	6BK5	.75	6L6	.78	7N7	.49	12SL7GT	.60
3S4	.48	6AQ5	.48	6BK7	.78	6S4	.41	12AL5	.43	12SN7GT	.56
3V4	.48	6AR5	.48	6BL7GT	.78	6S8GT	.65	12AT6	.37	19B6G	1.48

FREE \$7.20 list value Bonus Box of three 6SN7 tubes and 25 assorted resistors with each order of \$25 or more

SAME DAY SERVICE

48 Hour Postal Delivery To West Coast

TERMS: Save all freight and postage charges. All orders accompanied by full remittance will be shipped POSTAGE PAID anywhere in the continental U.S.A. 25% deposit required on COD's. Minimum order \$10.00. Open accounts to rated firms only.

Send for Free complete tube listing and monthly specials! Get on our mailing list.

SPECIAL!—till Nov. 1

Type	Price	Type	Price
OZ4	.39	12AT7	.53
1B3GT	.55	12BY7	.59
1S5	.35	12SA7	.43
5U4G	.39	12SK7	.43
6AU6	.33	12SQ7	.35
6BA6	.38	25W1GT	.39
6BQ6GT	.75	35L6GT	.39
6SN7GT	.48	50L6GT	.47
6W4GT	.35	11L7GT	.99

Watch for our monthly specials of key radio and TV types. Each month new key types will appear. Take advantage and order your requirements now.

TELTRON ELECTRIC COMPANY

428 Harrison Ave., Dept. RE-10 Harrison, N. J.
Phone Humboldt 4-9848

BEST BUY YET!



HERE IS YOUR OPPORTUNITY TO BUY A COMPLETE PROTELGRAM PHILIPS TV SYSTEM AT A REMARKABLE PRICE... THIS OFFER INCLUDES...

89⁹⁵

- 1 Chassis completely wired and ready for use, including 23 tubes plus one diode.
- 2 Protelgram projection unit including picture tube.
- 3 25,000 volt power supply ready for use.
- 4 8" dynamic speaker on large baffle.
- 5 23" flat viewing screen and full size reflecting mirror.

NOTE: Chassis includes... Automatic beam suppressor... High Fidelity sound system... Automatic gain control... "Standard Coil" Tuner, etc.

THE GOLDSTAR CO.
58 Walker Street, New York 13, N. Y.
Phone WA5-8187

HERE AT LAST!

CHEXALL

Vest Pocket Tester

A mighty mite. It virtually replaces the VTVM. Excellent sensitivity. Checks leakage beyond the range of most meters. Checks AC or DC Voltages. Checks presence of RF and High Voltages up to 30 KV. Tests and Quality checks all types of Condensers. Checks tubes, transformers and many other important applications!

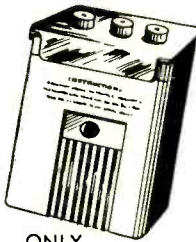

ONLY **\$8.95**

Complete Postpaid with leads and interlock cord.

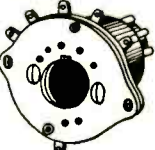

H-BAR-G "ADAPTEST"
\$1.95 Postpaid

NEW! IMPROVED!
H-BAR-G "ADAPTEST"

Checks CRT and Yoke setting, height, linearity and alignment. Can be used with vest pocket tester to check quality of CRT and operating voltages.

SAVE MONEY ON COMBINATION OFFER!
BOTH UNITS FOR **\$9.95**

Send Check or Money Order with order. Save C.O.D. and Postage Charges.

BRUNO-NEW JERSEY, INC.
12 HENNIION PLACE BLOOMINGDALE, N. J. DEPT. B



LOW-FREQ CONVERTER

Please print a circuit of a converter that will enable me to hear the Los Angeles radio range station weather reports (332 kc) on a standard broadcast receiver. If possible, I would like continuous tuning from 200 to 400 kc. The broadcast receiver has a 455-kc i.f.—B.E.M., Torrance, Calif.

The diagram of the converter is shown. Operating voltages may be taken from the receiver or from a separate power supply. The antenna and oscillator coils have adjustable powdered-iron cores that make it easy to track the circuits when using almost any standard type of tuning capacitor.

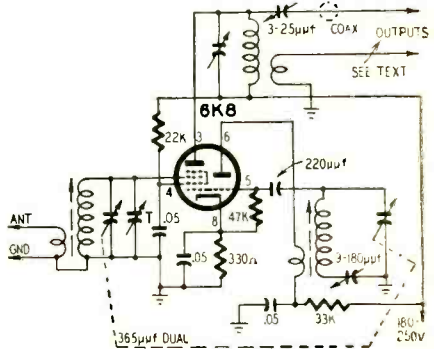

The oscillator coil is designed for a 455-kc i.f. and a 120-µf padder. With a 455-kc i.f. you will have to feed directly into the receiver's mixer plate or first i.f. grid circuit through a short length of low-impedance coaxial cable from the plate of the 6K8. The tuned coil in the 6K8 plate circuit may be

Interest in the Question Box, as indicated by letters received, is not high, and the question has arisen as to whether the space might not be better devoted to other subjects. What do our readers think? Should we: (1) continue the Question Box as is; (2) discontinue it; or (3) substitute some other material, and if so, what? Please mail your vote to Question Box, Radio-Electronics, 25 West Broadway, New York 7, N.Y.

one winding of a standard 455-kc i.f. transformer. The secondary coil is not needed.

If you want to couple the converter directly into the receiver's antenna terminals, shift the converter's output frequency into the broadcast band at around 550 kc. The coil in the 6K8 plate circuit should be a 500-600-kc converter output transformer with a low-impedance winding for feeding the

New 4-Speed Magnemite*

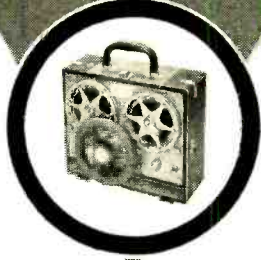

for Unmatched Versatility in Field Recording!

Designed for nature sounds, music, street sounds, interviews, conferences, courtroom reporting, missionary work and field reports. All of these may be recorded on a single 4-speed portable, battery-operated spring-wound tape recorder. Features quick speed change with automatic equalization.

Model 610 EM meets both primary and secondary NARTB standards and operates at tape speeds of 15, 7½, 3¾, 1½ ips. Records and plays back frequencies up to 15,000 cycles. Model 610 DM operates at tape speeds of 7½, 3¾, 1½, ¾ ips.

These tiny recorders weigh only 17 lbs. with self-contained batteries that last 100 operating hours and include built-in monitoring and headphone playback facilities. Designed for extreme simplicity of operation. Meets the most grueling field tests. May be operated anywhere. Measures only 7 x 10 x 11 inches.

Write for complete technical literature and direct factory prices to Dept. RE

AMPLIFIER CORP. of AMERICA

396 Broadway, N. Y. 13, N. Y.

*T.M. Reg. U.S. Pat. Off.

EASY TO LEARN CODE

It is easy to learn or increase speed with an Instructograph Code Teacher. Affords the quickest and most practical method yet developed. For beginners or advanced students. Available tapes from beginner's alphabet to typical messages on all subjects. Speed range 5 to 40 WPM. Always ready—no QRM.



ENDORSED BY THOUSANDS!

The Instructograph Code Teacher literally takes the place of an operator-instructor and enables anyone to learn and master code without further assistance. Thousands of successful operators have "acquired the code" with the Instructograph System. Write today for convenient rental and purchase plans.

INSTRUCTOGRAPH COMPANY

4701 Sheridan Rd., Dept. RC, Chicago 40, Ill.

URGENT! URGENT! ELECTRONIC TUBES

We Pay Spot Cash for:

RADIO, TV -all types

State types, condition of merchandise, quantities and price.

COLUMBIA ELECTRONICS CORP.

115 Liberty Street, N. Y. C.

ENJOY 3 COLOR TELEVISION FILTER SCREEN NOW

Changes dull eye-straining black and white pictures into beautiful color tones. Seconds to attach. No tools used. Helps eliminate glare and snow in fringe areas. Order direct. Send \$1 for screen size up to 16", \$1.25 size 17", \$1.50 size 20", \$2 size 21", \$2.50 size 24", \$3 size 27". We pay postage except on C.O.D. orders. Satisfaction guaranteed. Inquiries from dealers also welcomed.

Zingo Products, Johnstown 13, New York

receiver's antenna input circuit. Adjust the oscillator tuning slug and variable padder for proper tracking and coverage across the band at the selected i.f.

The circuit may be used also for shortwave reception by substituting suitable coils. For a single-band converter covering from 8.5 to 23 mc or 12.5 to 36 mc, we recommend using oscillator coils such as the J. W. Miller "W" series designed for 1500-ke i.f. service. These require a 1500-ke converter output transformer.

The antenna and oscillator coils for the 200-400-ke converter may be J. W. Miller types X-320-A and X-320-C or equivalents.

SERIES HEATER STRINGS

I have trouble calculating the values of the series and shunt resistors in series-connected heater strings where the tubes have different current ratings. Please show by example how the values of these resistors are calculated.—A.F., St. Louis, Mo.

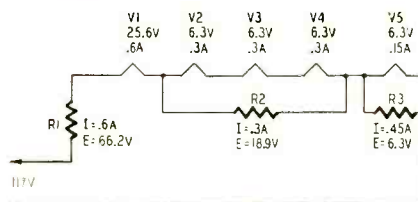

The diagram shows a typical series-connected heater string of the type you refer to. The series includes tubes with 0.6-, 0.3-, and 0.15-amp heaters. Ohm's law is used for all calculations.

The voltage drop across R1 is the supply voltage (117 in this case) minus the sum of the heater voltages of all tubes in the string. The current through R1 is that drawn by the tube with the highest current rating (V1). Using Ohm's law, R1 equals

$$117 - [(4 \times 6.3) + 25.6] \\ 0.6$$

or 110 ohms. R1 dissipates 39.7 watts (66.2×0.6)—its wattage rating should be doubled for adequate safety factor.

The voltage across a heater shunt resistor is the same as that of the tube or tubes it shunts. The current through it is the difference between the maximum circuit current and the current rating of the shunted tube or tubes. Excess current (0.3 amp) is shunted by R2 around V2, V3, and V4—R3 shunts the excess current (0.45 amp) around V5.

Still using Ohm's law, the resistance of R2 is $18.9/0.3$ or 63 ohms and its power dissipation is 18.9×0.3 or 5.6 watts. Similarly, R3 is $6.3/0.45$ or 14 ohms and the power dissipated is 2.9 watts. For adequate safety factor, the wattage ratings of R2 and R3 should be not less than 10 and 5 watts, respectively.

With the recent development of the 600-ma tubes for series operation, there will be greater use of series-string heaters by manufacturers. As a result, there will be many instances where shunting resistors will be used when making tube substitutions. END

COMPLETELY SERVICE... COLOR TV with only two NEW instruments!



RAINBOW GENERATOR
Model 150
Patent Pending

NEW CIRCUITS incorporated in this instrument greatly simplify the TEST and ALIGNMENT of color TV circuits. NEW LINEAR PHASE SWEEP produces the COMPLETE PHASE RESPONSE CURVE, assuring greater accuracy with faster alignment and elimination of color bar drift problems.

APPLICATIONS

- MASTER PHASE CONTROL test and alignment
- CHROMA DEMODULATOR test and alignment (either I/Q or R-Y/B-Y)
- QUADRATURE TRANSFORMER test and alignment
- MATRIX CIRCUIT test and alignment
- BURST AMPLIFIER test and alignment
- PHASE DETECTOR CIRCUIT alignment for reference oscillator
- REACTANCE CONTROL and REFERENCE OSCILLATOR adjustment
- 3.58 MC TRAP alignment
- TROUBLESHOOTING and PHASE ALIGNMENT in the home by picture patterns.



WHITE DOT GENERATOR
Model 160

THE WHITE DOT GENERATOR ENABLES COMPLETE ALIGNMENT OF ALL COLOR CONVERGENCE CIRCUITS PLUS SWEEP CIRCUIT LINEARITY AND SIZE, AS WELL AS GENERAL TROUBLESHOOTING BY SIGNAL TRACING.

APPLICATIONS

- DYNAMIC CONVERGENCE—vertical and horizontal test and adjustment
- DC CONVERGENCE—test and adjustment
- DEFLECTION COIL—positioning for best convergence
- BEAM MAGNETS—alignment for best convergence
- DYNAMIC PHASE ADJUSTMENT—vertical and horizontal
- FOCUS—test and adjustment of DC and dynamic focus
- TROUBLESHOOTING of all circuits affecting convergence
- LINEARITY—test and adjustment of horizontal and vertical sweep linearity
- TROUBLESHOOTING from antenna to picture tube by signal tracing.

WIN-TRONIX

WINSTON ELECTRONICS, INC.

Dept. 102, 4312 Main Street
Philadelphia 27, Pa.

MAIL TODAY. LEARN RADIO AT HOME WITH THE PROGRESSIVE RADIO "EDU-KIT".

BUILD 15 RADIOS ONLY

AT HOME \$19.95

With the New Improved 1955

Progressive Radio "EDU-KIT"

**NOW INCLUDES
HIGH FIDELITY,
SIGNAL TRACER, and
CODE OSCILLATOR**

- ATTRACTIVELY GIFT PACKED
- FREE SOLDERING IRON
- NO ADDITIONAL PARTS NEEDED
- EXCELLENT BACKGROUND FOR TV
- 10 DAY MONEY-BACK GUARANTEE
- SCHOOL INQUIRIES INVITED
- ABSOLUTELY NO KNOWLEDGE OF RADIO NECESSARY



WHAT THE PROGRESSIVE RADIO "EDU-KIT" OFFERS YOU

The Progressive Radio "Edu-Kit" offers you a home study course at a rock bottom price. Our Kit is designed to train Radio Technicians, with the basic facts of Radio Theory and Construction Practice expressed simply and clearly. You will gain a knowledge of basic Radio Principles involved in Radio Reception, Radio Transmission and Audio Amplification.

You will learn how to identify Radio Symbols and Diagrams; how to build radios, using regular radio circuit schematics; how to mount various radio parts; how to wire and solder in a professional manner. You will learn how to operate Receivers, Transmitters, and Audio Amplifiers. You will learn how to service and trouble-shoot radios. You will learn code. You will receive training for F.C.C. license.

In brief, you will receive a practical basic education in Radio, worth many times the small price you pay.

THE KIT FOR EVERYONE

The Progressive Radio "Edu-Kit" was specifically prepared for any person who has a desire to learn Radio. The Kit has been used successfully by young and old in all parts of the world. It is not necessary that you have even the slightest background in science or radio.

The Progressive Radio "Edu-Kit" is used by many Radio Schools and Clubs in this country and abroad. It is used for training and rehabilitation of Armed Forces Personnel and Veterans throughout the world.

The Progressive Radio "Edu-Kit" requires no instructor. All instructions are included. All parts are individually boxed, and identified by name, photograph and diagram. Every step involved in building these sets is carefully explained. You cannot make a mistake.

PROGRESSIVE TEACHING METHOD

The Progressive Radio "Edu-Kit" comes complete with instructions. These instructions are arranged in a clear, simple and progressive manner. The theory of Radio Transmission, Radio Reception, Audio Amplification and servicing by signal tracing is clearly explained. Every part is identified by photograph and diagram. You will learn the function and theory of every part used.

The Progressive Radio "Edu-Kit" uses the principle of "Learn by Doing". Therefore you will build radios, perform jobs, and conduct experiments to illustrate the principles which you learn. These radios are designed in a modern manner, according to the best principles of present-day educational practice. You begin by building a simple radio. The next set that you build is slightly more advanced. Gradually, in a progressive manner, you will find yourself constructing still more advanced multi-tube radio sets, and doing work like a professional Radio Technician. Altogether you will build fifteen radios, including Receivers, Transmitters, Amplifiers, Code Oscillator and Signal Tracer. These sets operate on 105-125 V. AC/DC. An Adaptor for 210-250 V. AC/DC operation is available.

THE PROGRESSIVE RADIO "EDU-KIT" IS COMPLETE

You will receive every part necessary to build 15 different radio sets. Our kits contain tubes, tube sockets, chassis, variable condensers, electrolytic condensers, mica condensers, paper condensers, resistors, line cords, selenium rectifiers, tie strips, coils, hardware, tubing, etc.

Every part that you need is included. These parts are individually packaged, so that you can easily identify every item. A soldering iron is included, as well as an Electrical and Radio Tester. Complete, easy-to-follow instructions are provided. In addition, the "Edu-Kit" now contains lessons for servicing with the Progressive Signal Tracer, F.C.C. instructions, quizzes, high fidelity instructions. The "Edu-Kit" is a complete radio course, down to the smallest detail.

TROUBLE-SHOOTING LESSONS

Trouble-shooting and servicing are included. You will be taught to recognize and repair troubles. You will build and learn to operate a professional Signal Tracer. You receive an Electrical and Radio Tester, and learn to use it for radio repairs. While you are learning in this practical way, you will be able to do many a repair job for your neighbors and friends, and charge fees which will far exceed the cost of the "Edu-Kit". Here is your opportunity to learn radio quickly and easily, and have others pay for it. Our Consultation Service will help you with any technical problems which you may have.

FREE EXTRAS

- ELECTRICAL & RADIO TESTER ● ELECTRIC SOLDERING IRON
 - TV BOOK ● RADIO TROUBLE-SHOOTING GUIDE ● CONSULTATION SERVICE ● QUIZZES ● F.C.C. TRAINING
- Progressive "Edu-Kits" Inc., 497 Union Ave., Dept. RE-97, Brooklyn 11, N.Y.

MAIL TODAY—Order shipped same day received.

10-Day Money-Back Guarantee. Include ALL FREE EXTRAS

- Send "Edu-Kit" Postpaid. I enclose full payment of \$19.95 (U.S.A. only).
- Send "Edu-Kit" Postpaid. I enclose full payment of \$20.95 (Outside U.S.A.).
- 210-250 V. Adapter for "Edu-Kit"—\$2.50.
- Send "Edu-Kit" C.O.D. I will pay \$19.95 plus postage (U.S.A. only).
- I wish additional information describing "Edu-Kit". No Obligation.
- Send me FREE Radio-TV Servicing Literature. No Obligation.

Name.....
Address.....

PROGRESSIVE "EDU-KITS" INC.

497 UNION AVE., Dept. RE-97, Brooklyn 11, N. Y.

BUILD 15 RADIOS AT HOME WITH THE PROGRESSIVE RADIO "EDU-KIT". MAIL TODAY

new Devices

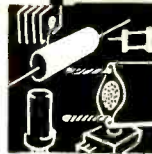

POLYMER

Sylvania Electric Products, Inc., Great Arrow Drive, Buffalo, N. Y., has introduced a new polymer, type 301, designed for laboratory and field measurements. The frequency range is from 20 cycles to 20 kc. It uses the new Sylvania 7-inch

tape. This practically eliminates any wrinkling and distorting of the tape at the hub. This reel also does away with



the need for thinning the tape coating.

CORNER HORN

G & H Wood Products Co., 75 N. 11 St., Brooklyn 11, N. Y., has announced the production of a new 20-inch Klipsch-designed corner horn speaker enclosure, the KR-5. This speaker enclosure may be wall-mounted, corner-hung, placed on a shelf, bench or table, and may be placed in any room.



meter movement, and reads peak to peak, a.c., d.c. voltages, and direct current. Resistance, decibel and zero-center scales are provided.

The a.c. and d.c. volt ranges are: 0-3, 10, 30, 100, 300, 1,000. The peak-to-peak volt ranges are: 0-8, 28, 80, 280, 800, 2,800. The d.c. milliampere ranges are: 0-3, 10, 30, 100, 300, 1,000. The d.c. ampere range is 0-10. Resistance ranges are: 0-1,000, 10,000, 100,000 ohms; 1, 10, 1,000 megohms. Input: d.c. range, 17 megohms; a.c. range, 2.7 megohms shunted by 40 µf (with unshielded lead) or 125 µf (with shielded lead).

HI-FI PREAMPLIFIER

Regency, Division of I.D.E.A., Inc., 7900 Pendleton Pike, Indianapolis 26, Ind., has introduced a high-fidelity preamplifier, model 350-P.

The features of the preamplifier include cathode follower output; equalization range of

The KR-5 approaches Klipsch horn performance on light middle bass, and is excellent for its size even on heavy bass.

Each unit is equipped with a handle to permit carrying from place to place, as well as a bracket for wall mounting. The finished model is available in honey walnut on walnut, French mahogany on mahogany, Korina, ebony, and leatherette. It has a 12-inch cutout with an 8-inch plate. The dimensions are 21 x 16 1/2 x 14 inches.



+18 to -20 db at 30 cycles and +14 to -20 db at 20,000 cycles; intermodulation distortion of 0.1% at 2-volts output (40 cycles and 7,000 cycles, 4:1).

RECORDING TAPE

ORRadio Industries, Inc., Opelika, Ala., has designed a new 7-inch reel with a 2 1/4-inch hub for Irish green-band magnetic recording tape. The new reel uses only one slot on the hub to secure the end of the

NEW CARTRIDGE

Webster Electric Co., 1900 Clark St., Racine, Wis., has announced the addition of a new

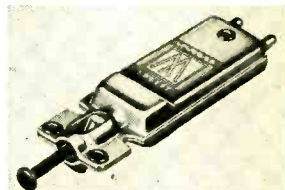

universal cartridge to their Featheride line. Known as the WX, this cartridge is a single-needle, dual-voltage model for either 78-r.p.m. or 3-speed use.

For high-voltage applications it develops 5 volts at 78 r.p.m. or 2 volts at 33½ to 45 r.p.m. Using the shunting capacitor which is furnished with the cartridge for low-voltage use, the WX develops 0.75 volt at 33½ to 45 r.p.m. or 1.5 volts at 78 r.p.m.

The WX weighs only 7.25 grams and comes packed in a plastic container to protect it against damage in handling. Besides the capacitor, the WX is furnished with an extra needle screw, terminal clips, and installation instructions.

COMPONENT TESTER

Transvision, Inc., Division of Sightmaster Corp., New Rochelle, N. Y., has announced a new improved TV component tester, model 100. It tests fly-back transformers and yokes, and will detect even one shorted turn. Model 100 tests picture tubes either in or out of tester for emission, short, or electrical



leakage. It is a selenium rectifier checker as well as picture-tube reactivator, renewing the emission of tubes which have deteriorated due to use or to shelf life. The unit checks capacitors for capacitance, shorts or opens, and also checks continuity.

ELECTRONIC SWITCH

Electronic Instrument Co., Inc., 84 Withers St., Brooklyn 11, N. Y., has designed the model 488 electronic switch to permit the simultaneous observation of two separate traces on the screen of one scope. It also serves as a square-wave generator over the range of switching frequencies.



The switch offers a means of comparing the amplitude, waveform, and phase of two signals; checking phase shift and waveform distortion; gain or frequency response of an entire amplifier or a single stage. It sets up a voltage reference level or zero base line, and pro-

vides square waves over sufficiently wide ranges for all square-wave testing of audio amplifiers.

The model 488 features continuously variable switching rates and square-wave frequencies in three ranges from less than 10 to over 2,000 cycles. Tube complement is: two 6AU6's, two 12AU7's, and one 6X5, transformer-operated.

FLYBACK

Gramer Halldorson Transformer Corp., 2734 N. Pulaski Rd., Chicago, Ill., has announced the FB417, a replacement assembly incorporating a high-

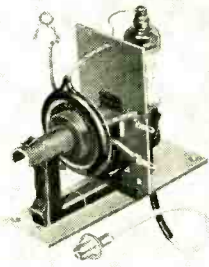

voltage rectifier socket and mounting to replace Crosley No. 15720-5-1 and Hallcrafters No. 550251.

Plaskoil, a plastic-coated high-voltage coil used in the FB417, possesses dielectric properties to guard against flashovers and breakdowns.

NEW MICROPHONES

The Astatic Corp., Conneaut, Ohio, has announced two new hand microphones, ceramic model M101 and crystal model M102. They are compact little units housed in plastic cases.

The output of the crystal M102 is -46 db, and that of the ceramic M101 is -53 db. Frequency range of M102 is 30 to



10,000 cycles, with flat response, while the range of the M101 is 30 to 8,000 cycles, with slightly rising characteristics in the high range.

LIGHTNING ARRESTER

Television Hardware Manufacturing Co., Division of General Cement Manufacturing Co., 919 Taylor Ave., Rockford, Ill., has announced a combination lead-in tube and lightning arrester. It is a lightning arrester on the outside end of the lead-in tube and a wall plug on the inside end.

A ¼-inch hole is drilled



At Last!

a complete

TUBE TESTER

\$ 24.90

for only

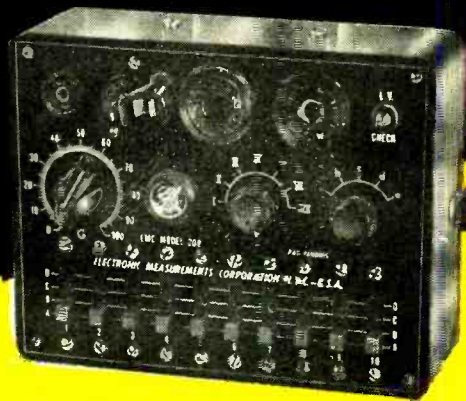

New EMC Model 208*

*Pat. Pending tests all tube types quickly... easily... accurately... in the field or shop.

The sensational new EMC Model 208* gives you for the first time a complete precision tube tester for less than \$25.00.

With it you can quickly and accurately test all tube types for quality as well as shorts, leakages, filament continuity and opens.

MODEL 208 TU3E TESTER (COMPLETELY WIRED AND TESTED) Only \$24.90

MODEL CRA (PICTURE TUBE ADAPTOR OF MODEL 208) \$4.50

CHECK THIS EXCLUSIVE COMBINATION OF FEATURES:

1. Lowest market price
2. Completely portable
3. Checks all popular octal, loctal, miniature and noval base tubes
4. Flexible switching system assures complete testing of all present and future tube types
5. Elements numbered according to RTMA base system
6. Individual sockets for each tube type
7. Checks completely for quality as well as shorts, leakages, filament continuity or opens between any two tube elements
8. Visual line voltage check with adjustable control assures accurate quality testing
9. Matches and checks HI-FI tubes such as 12L6, 6T 66, and 5881
10. Space saving, high impact case, 5¼ x 6¾ x 2¾"
11. Comes complete with detailed instruction book and tube listings

An invaluable tool for: Servicemen, radio hams, HI-FI fans, students, hobbyists.

Write to Dept. RE-10 today for complete catalog of precision test equipment.

EXPORT DEPT. - 36 LIBERTY ST. N. Y. 3, N. Y.

EMC

ELECTRONIC MEASUREMENT CORPORATION
380 LAFAYETTE STREET
NEW YORK 12, N. Y.

through the wall, and the device is fastened securely in place. Then the lead-in wire (any standard type) is attached to the lightning arrester where it makes contact through the arrester's serrated teeth. A standard antenna lead-in plug is fastened to the lead-in coming from the set and plugged into the other end of the lead-in tube.

TAPE RECORDER

Hudson Radio & Television Corp., 48 West 48th St., New York 36, N. Y., is distributing the *Ferrograph* tape recorder, made in Great Britain. Some features of this machine are: three independent drive motors, wide frequency response, high signal sensitivity, automatic cutoff in unattended operation,

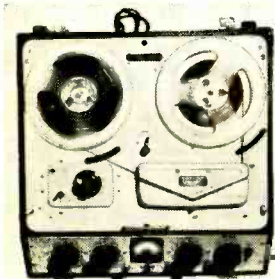

start and stop control, separate bass and treble adjustments, and metered input control.

The *Ferrograph* operates at either 3.75 or 7.5 inches per second. It is capable of double-track recording and playing. Rewind time is 1 minute. A

built-in preamplifier enables the machine to make full-depth recordings from signals as weak as .003 volt peak. Audio output is 2.5 watts. Recorded voice or music can be heard directly from a built-in loudspeaker or can be piped out to external speakers. The machine is self-contained and is readily transportable. It measures 18½ x 17½ x 9¼ inches, and weighs 50 lbs.

DISC CAPACITORS

Centralab, Division of Globe-Union Inc., 900 E. Keefe Ave., Milwaukee 1, Wis., has announced new 3,000- and 6,000-volt disc capacitors.

Designed for use in high-voltage circuits and television applications, these capacitors are 100% flash-tested at twice rated working voltage for maximum safety factor. The units also can be used for industrial electrical and electronic apparatus such as motor buffers, ignition quieters, and computers.

Type DD30, 3000-volt disc units are available in capacitances from 4.7 to 3,000 µf. The DD60, 6,000-volt capacitors are in the range from 4.7 to 1,500 µf.

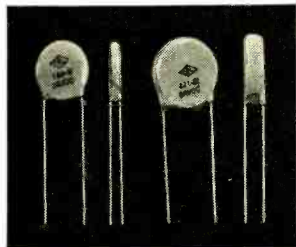

TURNTABLES

Rek-O-Kut Co., 38-01, Queens Blvd., Long Island City 1, N. Y., has announced two new 3-speed, 12-inch precision turntables. The *Rondine*, model B-12, is powered by a 4-pole induction motor; and the *Rondine Deluxe*, model B-12H, employs a hysteresis-synchronous, self-lubricating motor.

Aside from the motors, the two turntables are identical. A single selector knob is used for setting the desired speed: 33½, 45, or 78 r.p.m. Between the speed settings are intermediate "off" positions. These permit the turntable to be operated at any selected speed and then shut off without going through

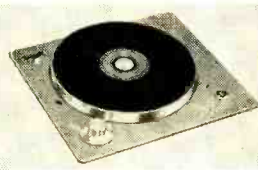

all of the speeds.

The *Rondine* features a built-in, retractable hub for 45-r.p.m. records and requires no external adapter.

STACKING KIT

Davis Electronics, 4002 W. Burbank Blvd., Burbank, Calif., has introduced a new antenna stacking kit that was designed to simplify stacking of two Davis *Super-Vision* antennas in weak-signal areas.

The kit may be used for either horizontal or vertical stacking.

V.H.F. ANTENNAS

Ward Products Corporation, 1148 Euclid Ave., Cleveland 15, Ohio, has introduced three new v.h.f. antennas called the *Ward Fringemaster*, and available in single and stacked models. The *Fringemaster* has the trap-bolt type of fold-up construction that prevents antenna collapse and forms a rigid and

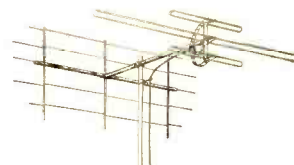

permanent assembly. It has polyethylene insulation throughout with seamless tubing elements and square aluminum tube supports and cross-arms.

It is available in the following stack models: single bay TV-285, quarter-wave stack TVS-286, half-wave stack TVS-287. Stacking kits are also available in TVS-288 and TVS-289.

CORRECTION

The address of the Jensen Manufacturing Co. was given incorrectly in the announcement of the new Jensen back-loaded cabinets on page 133 of last month's issue. The correct address is 6601 South Laramie Ave., Chicago, Ill.

END

All specifications given on these pages are from manufacturers' data.

Windsor

RADIO & TV RECEIVING

TUBES

GUARANTEED ONE FULL YEAR

... FOR PEAK PERFORMANCE!

THERE'S NO SUBSTITUTE FOR EXPERIENCE! And thousands of Service Dealers throughout America now know, FROM EXPERIENCE, that you can depend on Windsor Tube Quality. That's why we can safely guarantee each and every tube we ship, FOR ONE FULL YEAR! That's why the famous Green and Black Windsor Tube Carton is now accepted everywhere, as a symbol of QUALITY and RELIABILITY!

Type	Each	Type	Each
OA2	.90	IR4	.85
OB2	.88	IR5	.62
OC3	.95	IS4	.67
IA7GT	.67	IS5	.52
IAE4	.90	IT4	.61
IB3GT	.69	IU4	.61
IH5GT	.51	IU5	.51
IJ6	.93	IY2	.74
IL4	.63	IX2A	.45
IL6	.66	2X2	1.43
ILA4	.82	3A5	.90
ILB4	.80	3LF4	.76
ILC5	.82	3Q4	.66
ILC6	.80	3Q5GT	.72
ILD5	.80	354	.61
ILE3	.80	3V4	1.00
ILG5	.80	5R4GY	1.00
ILH4	.80	5U4G	.49
ILN5	.80	5V4G	.83
IN34	.90	5Y3G	.37
IN48	.50	5Y3GT	.42
IN5GT	.63	5Y4G	.43
IN64	.75	6A8GT	.68
		6AB4	.51

Type	Each	Type	Each	Type	Each	Type	Each
6AC5GT	.82	6BF6	.43	654	.51	7A7	.58
6AC7	.90	6BG6G	1.47	658GT	.75	7A8	.56
6AF4	1.10	6BH6	.63	65A7GT	.57	7AD7	1.05
6AG5	.59	6BJ6	.53	65C7	.63	7AF7	.63
6AH4	.68	6BK5	.76	65D7	.55	7AG7	.65
6AH6	.89	6BK7	.97	65F5GT	.66	7AH7	.65
6AK5	1.05	6BL7GT	.94	65G7	.55	7AJ7	.70
6AL5	.44	6BN6	.98	65H7GT	.52	7B4	.54
6AN8	.95	6BQ6GT	.98	65J7GT	.52	7B5	.51
6AQ5	.51	6BQ7	.92	65K7GT	.55	7B6	.52
6AQ6	.47	6BY5G	.85	65L7GT	.58	7B7	.58
6AQ7	.75	6BZ7	1.09	65N7GT	.69	7C4	1.05
6AR5	.42	6C4	.41	65Q7GT	.46	7C5	.56
6AS5	.55	6C5GT	.60	6T3	.85	7C6	.50
6AS7G	4.50	6C86	.58	6U4GT	.60	7C7	.58
6AT6	.42	6CD6G	1.57	6U5	.72	7E5	.85
6AU5GT	.85	6CS6	.56	6U8	.86	7E6	.65
6AU6	.47	6D6	.63	6V3	1.09	7E7	.85
6AV5	.85	6E5	.72	6V6GT	.51	7F7	.69
6AV6	.41	6F5GT	.54	6V8	.85	7F8	.97
6AX4	.72	6H6GT	.55	6W4GT	.50	7G7	.85
6B8G	.93	6J5GT	.44	6W6GT	.63	7H7	.61
6BA6	.50	6J6	.68	6X4	.37	7J7	.85
6BA7	.66	6J7	.70	6X5GT	.36	7K7	.85
6BC5	.58	6K6GT	.45	6X8	.82	7L7	.85
6BC7	.78	6K7	.70	6Y6G	.64	7N7	.62
6BD5GT	.98	6L6G	.88	6Y5	.60	7Q7	.62
6BD6	.54	6L6GA	.88	7A4/XXL	.57	7R7	.70
6BE6	.51	6Q7GT	.55	7A5	.70		
6BF5	.66	6R7	.75	7A6	.57		

FREE! WINDSOR TUBE CADDY

Most practical service-aid ever designed for Radio & TV repairmen! Now offered FREE with every purchase of \$160.00 or accumulated purchases totaling \$160.00 within 90 days. (You get Caddy credit memo with each purchase.)

- Carries approximately 125 tubes including meters and tools.
- 16¾" Long, 8¼" Wide, 13¾" High. Weighs only 9 lbs.
- Ruggedly constructed with heavy leatherette covering, strong plastic handle, nickel plated hardware, and reinforced with metal clamps.

WINDSOR TUBE CADDY MAY ALSO BE PURCHASED OUTRIGHT FOR \$14.95.

Note to our Latin-American Friends: "Se Habla Espanol!"

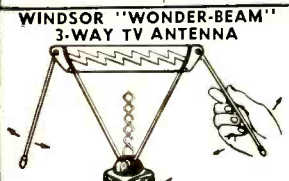
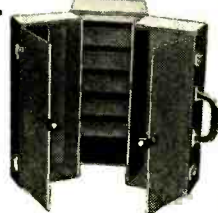

A real performer, this antenna works where others fail! Adjustable arms, for Average Areas, Fringe Areas, and UHF. Features new electronic wonder-switch; no need to rotate antenna, just turn wonder-switch for best results with each individual station! Works with any TV set.

SPECIAL PRICE \$5.69 Each

Lots of Six..... \$5.95 Each

Type	Each	Type	Each
I2J5GT	.48	25AV5	.85
I2S4GT	.57	25BQ6GT	.98
I2S5GT	.65	25L6GT	.53
I2SH7GT	.67	25W4GT	53
I2SK7GT	.55	25Z6GT	.46
I2SL7GT	.67	35A5	.55
I2SN7GT	.59	35A5	.55
I2SQ7GT	.46	35B5	.53
I2V6	.51	35C5	.53
I4A7	.58	35C6GT	.52
I4AF7	.68	35V4	.43
I4B6	.50	35Y4	.48
I4C5	.85	35Z3	.48
I4C7	.70	35Z5GT	.43
I4E6	.70	50A5	.55
I4E7	.85	50B5	.52
I4F7	.69	50C5	.52
I4F8	.99	50L6GT	.52
I4J7	.85	50X6	.55
I4N7	.75	117Z3	.43
I4Q7	.62	117Z6GT	.75
I4R7	.85		
I4S7	.80		
I9BG6G	1.53		
I9T8	.87		

WINDSOR "BROW-LITE"

- Leaves Both Hands Free to Work!
- Wear it on your Brow.
- Adjustable angle of Beam.
- Ideal for Radio & TV Repairmen.
- Uses standard penlite batteries and bulb.
- Won't interfere with glasses.

Complete with Batteries **\$4.95**

Windsor ELECTRONIC TUBE CO.
2612-C NOSTRAND AVENUE, BROOKLYN 10, N. Y.

Write for Additional Tube Types and Prices. We also stock Special Purpose and Timing Tubes at Similar Savings! Dept. C-10.

radio-electronic Circuits

SIMPLE TESTER FOR TV TUBES

The more common TV receiver troubles are caused by gassy, leaky, or shorted tubes in r.f. and i.f. circuits.

Robert Stevens, of Nashville, Tenn., has developed a novel miniature tube tester for leakage, gas, and shorts in

vent shorts should the case contact a hot chassis or a grounded object.

The tube heater pins are paralleled across the secondary of a 6-volt heater transformer and are connected to B plus through a 47,000-ohm resistor.

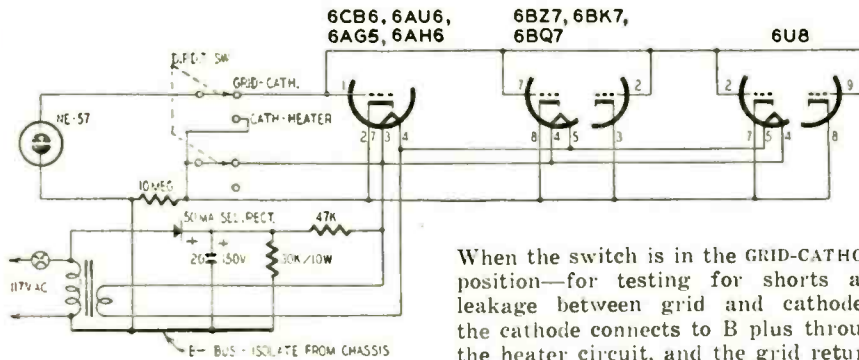

the more common types of tubes used in TV r.f. and i.f. circuits. The circuit of the tester is reprinted here from *Motorola Service News*. The model is made in a 2 x 3 x 7-inch metal box. One 9-pin miniature socket is provided for testing twin triodes like the 6BZ7 and 6BK7 and another is used for 6U8's. A 7-prong miniature socket tests 6AU6's and similar pentodes.

The B supply is a half-wave transformerless type connected directly across the power line with a 50-ma selenium rectifier supplying the d.c. voltage. The common negative bus is carefully isolated from the metal case to prevent a shock hazard and to pre-

vent shorts should the case contact a hot chassis or a grounded object. When the switch is in the GRID-CATHODE position—for testing for shorts and leakage between grid and cathode—the cathode connects to B plus through the heater circuit, and the grid returns to ground through the neon lamp. This places a fairly high d.c. voltage between grid and cathode. The lamp glows when the tube is gassy, when it draws grid current, or when leakage or a short between grid and cathode is 30 megohms or lower.

Switching to CATHODE-HEATER disconnects the cathode from B plus and grounds it through the neon lamp. A leakage path of 2 megohms or lower between heater and cathode causes the lamp to glow.

Connect a resistor of about 40 megohms from the grid line to B minus if the lamp glows slightly on good tubes with switch in GRID-CATHODE position.

METER-PROTECTION CIRCUIT

This circuit protects the meter in a v.t.v.m. against damage by excessive current when the range setting is too low for the applied voltage. Connect a resistor (R1) and 1N56 diode as shown. R2 and R3 are original circuit components. The resistance of R1 is selected so the drop across it is a little greater than the drop across the meter when it passes full-scale current. For normal operation, the drop across R1 biases the diode to cutoff when the cathodes of V1 and V2 are at the same potential. When the cathode of V1 goes sufficiently positive to overload the meter, the diode conducts and short-circuits the meter, thus protecting it against excessive current.

This kink is particularly effective when the meter has a relatively high internal resistance and when several milliamperes flow through R2. R1 is

about 56 ohms in a typical v.t.v.m. circuit.

Crystal diodes other than the 1N56 can be used with equal effectiveness. Since most of these diodes have slightly

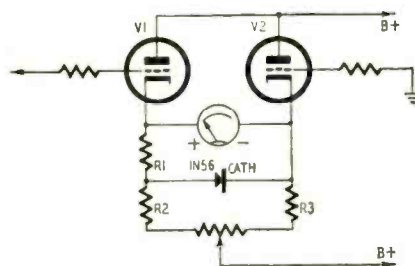

varying characteristics, it will be necessary to experiment with the value of R1 to find the most efficient point of operation.—Dan McMorris

for **ALL METERS**
ALL RANGES

**BOLAND & BOYCE
UNIVERSAL**

High Voltage Probe

Complete with plug-in resistors for any range, any meter

Make safe, accurate high-voltage measurements with any voltmeter, multimeter, or VTVM having sensitivities of 10,000 ohms-per-volt or more.

The new Boland & Boyce Universal High-Voltage Probe can be used with different instruments for dozens of ranges . . . and it is safe and easy to use in the bargain. Complete with 4 plug-in precision resistors and instructions for matching virtually any meter . . . any range—10KV, 30KV, 60KV, and intermediate ranges. Clear, high-dielectric handle shows resistors in use. Includes shielded cable with Amphenol connectors. B&B MODEL 702 HV PROBE —\$11.95 net.

TEST C-R TUBES & CIRCUITS under receiver's own power



Measure both TV picture tube or receiver performance in one all-inclusive test! Two cabled leads of B&B C-R Tube Tester connect between tube and receiver.

8-position switch tests: grid-cathode, heater-cathode, and grid-screen leakage; grid cathode voltages; receiver screen and video output voltages; beam current at HV anode; grid control of beam; effect of brightness and contrast controls; and much more.

Instantly isolates tube or receiver faults. Separate plug-in power supply available for in-carton tube testing. Prices include 2 cabled leads and instruction manual. KIT—\$29.95. FACTORY WIRED & TESTED—\$39.95. Sold by leading distributors.

New! B&B Model 704 BIAS BOX



An exact, steady source of d-c bias voltage, 0 to 17 volts. A "must" for radio and TV realignment. Clips and grounds to chassis apron; connects to nearest 6.3-V heater voltage terminal. Kit only \$9.95. Assembled, wired and tested, \$12.95.

Write for brochure describing B&B products.

BOLAND & BOYCE, Inc.

Dept. RE-104, 236 Washington Avenue
Belleville 9, N. J.

NEW! All Channel VHF-UHF TV RECEPTION IN ALL DIRECTIONS

Our Greatest BARGAIN

Only \$23.50

Model AX-524

ROCKET DIRECTRONIC MOTORLESS TV ANTENNA
360° ELECTRONICALLY SWITCHED BEAM

In the fringe of ultra-fringe, the NEW 1954 Motorless Directronic will out-perform any ordinary antennas. This sensational new 360° UHF-VHF TV Antenna offers "around the compass" reception WITH-OUT Rotors. Provides superb ghost-free picture clarity. Model AX-524 "Service-men's Array" contains Hi-Pec Moulded Insulator of Extreme tensile strength, 24 hi-tensile aluminum elements, including 6 Multi-purpose Reflector-directors, 1 set matched tie rods, Universal Mast Clamps, 6-position Beam Selector Switch, 75' Low-loss UHF-VHF Tubular TR-1-X Cable.

HI-GAIN BOW-TIE REFLECTOR
For UHF \$1.95 Each

High gain at low cost. Completely pre-assembled. Easily stacked for fringe use.

2 Bay with tie rods \$4.40
4 Bays with tie rods 9.95
Lots of 6-Individually car-
toned 10.95

Save With Rocket 35 Foot Mast Kits

Economy mast kit contains 3 self-coupling 10' seamless TR-1 COATED 1 1/2" O.D. mast, 300 feet of 6/20 galvanized steel guy wire, and everything else needed including guy rings, insulator, cable clamps, guy hooks, and swivel mounting base.

35 foot Mast Kit . . . \$15.95 25 foot Mast Kit . . . \$11.95

Save With Rocket 35 Foot Mast Kits

RADIART TELEROTOR

Radiart's famous TR-2 at new money-saving price. Powerful, rusted, weather-proof - handles installations up to 150 lbs. Conv- tory box light indicates orientation of antenna. Factory lubricated for life. Truly a good buy at our new price. Uses 8-con- d. wire. 8-cond. wire . . . \$0.08 ft.

MODEL TR-2

\$26.97

ALL PRICES F.O.B. CLEVELAND, OHIO
Do not remit more than complete purchase price. Pay shipping charges on receipt of goods. 25¢ deposit on all C.O.D. orders, please. Money-back guarantee. Prices Subject to Change Without Notice

2-BAY 16-ELEMENT CONICAL ARRAY With Hi-Band Adapters

Sturdy 3/8" Elements

\$4.99 EACH IN LOTS OF THREE SINGLE LOTS \$5.30

Never before has National Electronics had a BARGAIN like this. We made a special purchase in order to get these sensational prices. And this array has everything. This conical 2-bay 16-element array provides ultra-fine fringe reception. Includes sixteen 3/8 inch airplane type aluminum elements, including hi-band adapters for greater gain on the high channels and is complete with one pair of stacking bars to each array. These are packed in cartons of three 16-element arrays per carton, with tie rods, at \$14.95 per carton. When purchased in single 16-element arrays, separately boxed - your cost is \$5.30 each

3 Two-Bay Arrays per carton without Tie Rods \$13.50 carton
1 Bay Ultra-Fringe Stacking Assembly for Above - Model 48 \$1.95 set

ROCKET BROAD BAND YAGIS

• SENSATIONAL GAIN
• SENSATIONAL PICTURES IN FRINGE AND ULTRA FRINGE AREAS

Switch to Yagi Broad Band Hi-Gain Antennas! These new Yagis give you Yagi reception on the 5 low-band and 7 hi-band channels - no restriction to one single channel. A two-bay array will out-perform even a 10 or 12-element single channel Yagi. Price is sensationally low. Complete serviceman's array includes 1 double reflector, 2 folded dipoles, 3 directors, Universal mast clamp, Easy-to-assemble quick rig construction.

Model RB 24 - Ch. 2 thru 6-7-element . . . \$10.95 ea.
Model RB 713 - Ch. 7 thru 13-9-element . . . 5.95 ea.
Matched Stacking Bars 1.25 ea.

National Electronics OF CLEVELAND
THE HOUSE OF TV VALUES
270 Delco Building, Cleveland 3, Ohio

BLAK-RAY SELF-FILTERING ULTRA-VIOLET LAMP

BLAK-RAY 4-watt lamp, model X-4, complete with U-V tube. This lamp gives long-wave ultra-violet radiation having a wave-length of 3654 to 4000 angstrom units. Some of the substances made to fluoresce visibly when illuminated by U-V light are certain woods, oils, minerals, milkstone, cloth, paints, plastics, yarn, drugs, crayons, etc. This lamp is self-filtering and the invisible U-V rays are harmless to the eyes and skin. Equipped with spectral-finish aluminum reflector. Consumes only 4 watts and can be plugged into any 110 volt 50-60 cycle A.C. outlet. Will give 2000 to 3000 hours of service. It weighs but 1 1/4 lbs. Approved by the Underwriters Laboratories and has a built-in transformer so that it may be safely used for long periods when necessary. Extra U-V tubes are available.

Ship wt. 4 lbs.
ITEM NO. 125
UNUSUAL BUY (Shp. Chgs. 70¢)

\$16.75

POWERFUL ALL PURPOSE MOTOR

Sturdy shaded pole A.C. induction motor. 15 watts, 3000 rpm. 3"x2"x1 3/4". 4 mounting studs; 7/8" shaft, 3/16" diameter; 110-120 volts, 50-60 cycles A.C. only. When geared down, this unit can operate an 18" turntable with a 200 lb. dead weight. Use it for fans, displays, timers and other purposes. Ship wt. 2 lbs.

ITEM NO. 147
UNUSUAL BUY (Shp. Chgs. 35¢)

\$2.45

WATT HOUR METER

Leading makes-reconditioned. Ideal for trailer parks. 100-110 volts, 60 cycles, 2-wire A.C. 5 amp. Heavy metal case 8 1/2" x 6 1/4" x 5". Easy to install. Ship. wt. 14 lbs.

ITEM NO. 33
NOW ONLY (Shp. Chgs. \$1.25)

\$4.50

WESTERN ELECTRIC BREAST MIKE

Lightweight 1 lb. carbon microphone. Aircraft type. Breastplate mounting, adjustable 2-way swivel. Easily fastened straps. For home broadcasts, communications etc. Complete with 6 foot cord, hard rubber plug. Sheradized plate, non-rusting finish. Ship. wt. 2 lbs.

ITEM NO. 152
NEW LOW PRICE (Shp. Chgs. 32¢)

\$1.98

AMAZING BLACK LIGHT

250-watt ultra-violet light source. Makes fluorescent articles glow in the dark. Fits any lamp socket. For experimenting, entertaining, unusual lighting effects. Ship. wt. 2 lbs.

ITEM NO. 87
A SAVING AT (Shp. Chgs. 35¢)

\$2.45

250 POWER TELESCOPE LENS KIT

Make your own high powered 6 ft. telescope! Kit contains 2" diam., 75" focal length, ground and polished objective lens and necessary eye pieces. Magnifies 50x to 250x. Full instructions. Ship. wt. 1 lb.

ITEM NO. 123
YOU SAVE AT (Shp. Chgs. 10¢)

\$2.95

HUDSON SPECIALTIES CO.
25 West Broadway, Dept. RE-10-54
New York 7, N. Y.

I am enclosing full remittance for items circled below. Be sure to include shipping charges.

DR. my deposit of \$ Ship balance C.O.D.
MINIMUM C.O.D. ORDER \$5.00.
C.O.D. ORDERS ACCEPTED ONLY WITH 20% DEPOSIT INCLUDE SHIPPING CHARGES.

Circle items wanted

87 147 33 152 128 123

Name Please Print Clearly
Address
City Zone State

SAVE MONEY ON INSTRUMENTS!

basic electronic test instruments

How to test better with fewer instruments . . .
How to use old instruments in new ways . . .
How to select the instruments you need . . .
How to evaluate instrument readings and put them to practical use.

BASIC ELECTRONIC TEST INSTRUMENTS

by Rufus P. Turner

254 pages, 171 illus., Price \$4.00

Written especially for servicemen, amateurs and experimenters, this new book is a complete training course in instruments. Over 60 instruments - from the most modern TV pattern generators to grid-dip oscillators and special-purpose bridges - are fully explained. Work-saving short cuts are outlined. You learn how to put your old instruments to new uses, and thus avoid buying costly new ones. Tells all about current and voltage meters; ohm-meters and V-O-M's; V-T voltmeters; power meters; oscilloscopes; r-f test oscillators; signal tracers; tube testers; TV linearity pattern generators; sweep and marker generators; square-wave generators; distortion meters and dozens more.

READ IT 10 DAYS . . . at our risk

Dept. RE-104, Rinehart & Co., Inc.
232 Madison Ave., New York 16, N. Y.

Send Turner's BASIC ELECTRONIC TEST INSTRUMENTS for 10-day examination. If I decide to keep book, I will then remit \$4.00 plus postage in full payment. Otherwise, I will return book post-paid and owe you nothing.

Name
Address
City, Zone, State

OUTSIDE U.S.A. - Price \$4.50, cash with order. Some return privilege with money refunded.

Concord Radio from our New 1955 Catalog

Genuine TELECHRON

Switch Timer Clocks

Below WHOLESALE Cost!

Make Your Clock Radio Turn Appliances "ON"

\$3.85 Lots of 3

\$3.95 ea.

Brand New, individually boxed TELECHRON (GE) Switch Timers at a fraction of their original price. Will turn appliances on at any pre-set time up to 12 hours. Operates on 115 Volts 60 cycle A.C. Appliance switch rated at 115 V. 15 Amps. Has 3 control knobs, all on front of clock - on-off-auto knob for controlling appliances. Auto Set knob for pre-setting turn-on time, and Time-set knob. Clock mounts in a 2 1/2" diameter hole. Comes complete with handsome polished brass rim and bezel with easy-to-read engraved numerals. Stock No. 99-G-C40B-G7

Shpg. Wt. 1 1/2 lbs

CONCORD RADIO 54 Vesey St., N. Y. 7.

Dept. C10 20% deposit with C.O.D. MINIMUM ORDER \$5.00

Send new 1955 CATALOG!

NAME
ADDRESS
CITY ZONE STATE

CONCORD RADIO • 53 VESEY ST. N. Y. C.

AUTO RADIO SUPPLY

Recently a defective auto radio was brought in while my 6-volt battery eliminator was not available. The symptoms showed that the trouble was not in the vibrator or power supply so I used a simple trick to supply heater and B plus voltages to the set while it was on the test bench.

I disconnected all wiring from the center tap on the primary of the vibrator transformer and removed the vibrator from its socket. (Removing the vibrator is very important!) I then connected the secondary of a heavy 6.3-volt filament transformer across

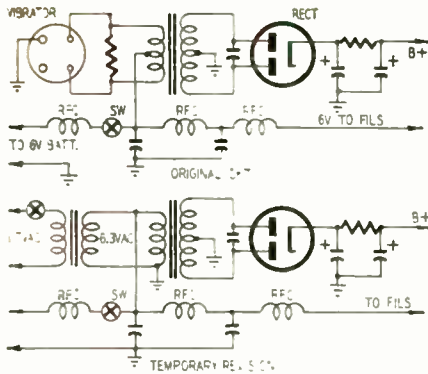

the primary of the vibrator transformer and grounded one side of the winding to the chassis. The modification was completed by connecting the high side of the 6-volt winding to the hot side of the heater circuit.

Caution! Do not use this scheme on sets with electrodynamic speakers without first disconnecting the field coil and substituting a PM type speaker.—*Russell Harknett*

PHONO OSCILLATOR

I have constructed many phono oscillators and have listened to a great many more, but I've never heard one whose quality compares with that obtained with this circuit. Bass response is good without noticeable hum modulation.

The oscillator uses the right-hand half of the 6Z7-G connected as a tickler-feedback circuit. The coil is a standard broadcast antenna transformer with the grid winding tuned by a 365- μ mf capacitor.

The 6SJ7 preamplifier is direct-coupled to the grid of the modulator half of the 6Z7-G. With this connection, the grid is around 100 volts positive. Normal operating bias is provided by the 22,000-ohm cathode resistor. The modulator section operates as a

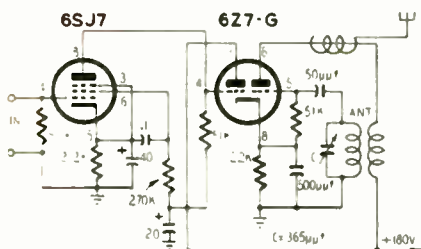

cathode follower modulating the cathode of the oscillator.—*Wayne Miller*

Look to ...the only full line of phonomotors!

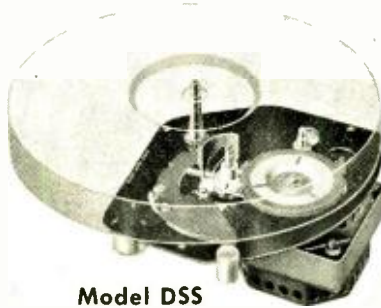

Model DSS
33 1/2-45-78 r. p. m.

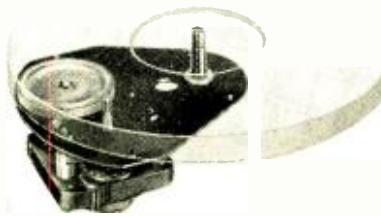

Model AX
78 r. p. m.

There's no problem in selecting the phonomotor that *best* meets your requirements when you choose from the GI Smooth Power line. It's the most complete line in the industry...backed by the fifty-one-year-old reputation of America's leading manufacturer of phonomotors, recording motors, tape-disc recording assemblies and disc recording assemblies.

HIGHEST QUALITY—Model DSS

4-pole motor, 115 volts a. c., 60 cycles
For three-speed applications in which compactness is secondary to need for absolute minimum of stray field radiation. Ideally suited for all types of pickups, including magnetic.

Features include precision construction throughout, oilless motor and turntable bearings, dynamically balanced rotor. Moving lever to "OFF" position automatically disengages idler wheel from motor shaft, and cuts off current.

LOWEST COST—Model AX

2-pole motor, 115 volts a. c., 60 cycles
Low-priced, single-speed, rim-drive motor suitable for installations where size and cost are prime factors. Incorporates features found in more expensive motors.

OTHER MODELS

A complete line of 78 r.p.m., two-speed and three-speed motors. The popular Model SS (not shown) is a compact 3-speed phonomotor incorporating the vertical idler shift principle and shift lever which disengages idler wheel from motor shaft during non-operating periods.



Write for catalog containing dimensions and specifications of these and many other single-speed, dual-speed and 3-speed models in the Smooth Power phonomotor line.

THE GENERAL INDUSTRIES CO.
DEPARTMENT ME • ELYRIA, OHIO

OVER 97,000 TECHNICIANS HAVE LEARNED HOW TO GET THE MOST OUT OF BASIC TEST EQUIPMENT for AM FM-TV

'Servicing by Signal Substitution'

A BEST SELLER FOR OVER 13 YEARS!
(NEW, UP-TO-DATE, 14th EDITION)

The Modern, Simplified, Dynamic Approach to all Receiver Adjustment & Alignment Problems

- ★ Nothing complicated to learn
- ★ No extra equipment to purchase
- ★ Universal . . . non-obsolete
- ★ Employs only Basic Test Instruments

Ask for "S.S.S." at your local Radio Parts jobber or remit 40¢ in small stamps or coin directly to factory.



ONLY 40¢

103 pages. Invaluable information that will help you redouble the value of your basic test equipment.

PRECISION APPARATUS COMPANY, INC.
92-27 HORACE HARDING BLVD., ELMHURST 4, N. Y.

LEARN COLOR TV THIS EASY WAY!

Just off the Press!

ABC OF COLOR TV



H. G. Cisín's remarkable book takes the mystery out of Color TV. The only book which explains this fascinating new TV development in a simple down-to-earth manner. It actually translates the highly technical descriptions of research scientists into plain everyday language.

Covers basic color principles, compatible color TV system, the color signal, color TV reception, plus practical pointers on color TV tubes, tests, servicing, antennas, etc. Just the info TV servicemen must have to cash in on this rapidly expanding new field. Profusely illustrated.

Only \$1

NEW! 1955 ATTENTION: NOVICE SERVICEMEN!

TV DOCTOR



The new TV DOCTOR was written expressly for you by H. G. Cisín, noted TV educator and author. Mr. Cisín has trained thousands of TV technicians, many of whom are holding important positions in television. His years of experience are embodied in this valuable book!

TV DOCTOR contains just the info you need as you start in TV servicing. No theory, math or formulas, but full of practical information. Copyrighted Trouble-Shooting Guide pin-points hundreds of TV troubles, enabling you to diagnose faults without previous experience. Method applies to all TV sets, old and new. Special chpt. on COLOR TV. Useful data about TV sets, tuners, antennas, lead-ins, interference, safety suggestions. Many clear illustrations.

Only \$1

FAMOUS "TV CONSULTANT" TV Serviceman's Silent Partner



New, easy-to-use way to solve toughest TV troubles. UHF sect. includes conversions, installations and servicing. Modern alignment methods shown by pictures, diagrams and simple directions, tell exactly what to do and how to do it. Practical pointers on use of all TV Test Instruments. Over 300 pix, raster and sound symptoms. Detailed directions tell where and how to find faulty parts. Over 135 RAPID CHECKS. Many using pix tube as trouble locator. 125 illustr. of scope wave forms, diagrams, station patterns, show various defects—take mystery out of TV servicing. NO THEORY—NO MATH—NO FORMULAS—just practical service info. covering all types of TV sets.

Only \$2

NEW! 1954 TV TUBE LOCATOR

Copyrighted TROUBLE INDICATING TUBE LOCATION GUIDES for over 3000 most popular models from Admiral to Zenith plus PIX TUBES used in each model! 1947 to 1953 models. A store-house of valuable TV servicing info. priced very low for large volume sales.

Only \$1

NEW! Trouble Shooting PIX GUIDE incl. TV TERMS Explained

Set. 1 is a fully illustrated GUIDE to oft-recurring pix faults. Causes and cures explained. Copyrighted Trouble indicating illustrated chart tells where troubles start in typical TV set—illustrations show resulting faulty TV pictures. Set. 2 explains hundreds of TV terms in non-technical language.

Only \$1

NEW! TV TROUBLE TRACER

Each vol. contains different copyrighted "Trouble Indicating" TRIPLE LOCATION GUIDES for over 500 most popular TV models. Vol. 1 older sets, vol. 3 newest 1954 models. 40 common picture troubles illustrated, traced to source and cured.

Vols. 1, 2 & 3—Only 50c ea.

H. G. CISIN, PUBLISHER

Order from your Jobber today, or if not stocked, write to

Harry G. Cisín, Dept. E-28
Amagansett, New York

Enclosed find \$..... Send

- | | |
|--|--|
| <input type="checkbox"/> Color TV | <input type="checkbox"/> TV Pix Guide |
| <input type="checkbox"/> TV Doctor | <input type="checkbox"/> TV Tracer, Vol. 1 |
| <input type="checkbox"/> TV Consultant | <input type="checkbox"/> TV Tracer, Vol. 2 |
| <input type="checkbox"/> TV Tube Locator | <input type="checkbox"/> TV Tracer, Vol. 3 |

Name

Address

City Zone..... State.....

ELECTRONIC SWITCH

Two of the main drawbacks to using conventional electronic switches for double-trace scope studies are that serrated traces are usually obtained and that a number of scope and switch controls must be adjusted for best results. The scope's fine-frequency and scope-amplitude controls are critical and often interact. The conventional electronic switch has coarse and fine switch-frequency controls that must be synchronized with those on the oscilloscope.

Obtaining double traces on a scope is easier when you use an electronic switch that does not require frequency controls. The diagram shows how this may be done by replacing the usual free-running multivibrator with a bi-stable flip-flop triggered by the scope's sweep oscillator. Some of the advantages of this circuit are:

1. The critical switching frequency adjustments have been virtually eliminated.
2. The scope traces are not broken

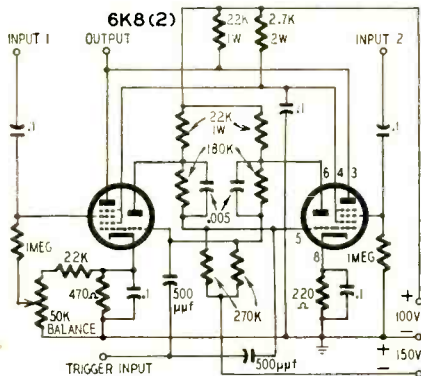

by the switching process, so they are clean and sharp regardless of the frequency.

3. The switching frequency need not be higher than the scope's sweep frequency because switching occurs during the retrace.
4. The circuit uses fewer components than the more conventional ones of this type.

The circuit shown uses two 6K8's with their triodes connected in a flip-flop circuit and the pentodes as switched amplifiers. The trigger pulse is taken from the scope's sawtooth oscillator. With thyratrons such as the 884, 885, and 6Q5-G, you can take the trigger voltage from the plate end of the discharge-current limiting resistor.

The signals fed into the pentodes may be controlled by potentiometers; but since these affect high-frequency response, compensated step attenuators or cathode followers are preferable.

The 270,000- and 180,000-ohm resistors are the only critical components. If different tubes or voltages are used, you may have to substitute other values for the two 180,000-ohm triode grid resistors. Be sure to keep the two resistors equal regardless of the final value selected. This will make for a stable smooth-operating double trace on the scope.—Meir Weger

GREAT SAVINGS | Fall Specials

TV PICTURE TUBES ONE YEAR GUARANTEE

10BP4 .. \$10.95	17BP4 .. \$16.95
12LP4 .. 11.95	17CP4 .. 17.95
12LP4A .. 12.95	17GP4 .. 18.95
12OP4 .. 12.95	17HP4 .. 18.95
12JP4 .. 12.95	19AP4 .. 19.95
14BP4 .. 13.95	19BP4 .. 18.95
16RP4 .. 15.95	19DP4 .. 18.95
16AP4 .. 16.95	20CP4 .. 19.95
16CP4 .. 16.95	21AP4 .. 22.95
16GP4 .. 16.95	21EP4 .. 21.95
16DP4 .. 15.95	21FP4 .. 22.95

All Prices With Old Tube

Add \$5.00 deposit to tube price. Deposit is fully returned upon receipt of your old tube.

630-DX TECH-MASTER CHASSIS, \$145.00
with Cascode Tuner now \$125.00

UHF CONVERTER Mfd. by Tech-Master for 630-DX or any 630 Chassis. (Fits into well) \$32.50 of chassis)

TV Wire, 300 ohm, 55 mil. 100 ft. \$1.00

DEFLECTION YOKES
60° Yokes..... 69c ea.
70° Yokes..... \$1.95 ea.

New CASCODE Tuners
Complete..... \$14.95
factory aligned

FP CONDENSERS with Metal Plates. 4-Sections
20/150V. 25c
3-20/20V. 39c
10 for \$1.95 ea. 10 for \$3.49 ea.

Special! VARIABLE CONDENSERS
2 gang super het 29c ea.
3 gang AM/FM 89c ea.

CONTROLS
2 meg. IRC..... 39c ea.
5w. for above. 9c ea.
25K, Type J, AB..... 6/89c
180K Type J, AB..... 6/89c

CRYSTAL MIKES
Removed from new equipment. 69c ea. hearing aid type
All perfect! 3 for \$1.89
Miniature Chokes 29c ea.
3 leads, 3K ohms hearing aid type. 4 for \$1.

WRITE FOR FREE NEW CIRCULAR. Terms: 25% dep. with order, bal. C.O.D. F.O.B. New York City. Prices subject to change without notice.

ROSE ELECTRONICS, Inc.

76 Vesey St., New York 7, N.Y. | CO. 7-6195

ALMO RADIO COMPANY Offers Terrific Savings on Used Test Equipment

SUPREME 589-A (Only 2 Left)	\$19.95
TUBE CHECKER	\$24.50
SUPREME 576 OSCILLATOR	\$19.00
APPROVED 516 OSCILLATOR	\$39.00
RIDER CHANNELIST "RACK MFG."	\$29.50
MERIT VACUUM TUBE VOLTMETER	\$29.50
JACKSON 106 SIGNAL GENERATOR	\$29.50
JACKSON 112 CONDENSER CHECKER	\$49.50
PRECISION E-200C OSCILLATOR	\$99.50
HICKOK 610-A ALIGNMENT GENERATOR	\$34.50
HEATH SCOPES (Only 2 Left)	\$99.50
PRECISION ES-500-A SCOPE	\$45.00
EICO 425-A SCOPE	\$14.95
OAK RIDGE Model 104 SWEEP GENERATOR	\$17.95
OAK RIDGE Model 105 MULTI TESTER	\$14.95
OAK RIDGE Model 106 CATHODE RAY—(TUBE TESTER)	

Available only at our main store
Come in, write or call

ALMO RADIO CO.

509 ARCH ST. PHILA., PA.

Phone: WA 2-5153

When answering advertisements please mention
RADIO-ELECTRONICS



Merchandising and Promotion

Channel Master Corp., Ellenville, N. Y., recently completed a survey that revealed more than 100 different areas throughout the U. S. were getting TV reception on channels spoiled by "venetian blinds" and other severe forms of co-channel and adjacent-channel interference. The problem is encountered primarily on low-band v.h.f. channels. The survey was conducted to ascertain the market for the company's new *Backstop* one-way antenna designed for this problem.

Radio City Products Co., Easton, Pa., designed a counter display card for its new universal high-voltage multiplier probe, HVMP-C.

Jensen Industries, Forest Park, Ill.,



came up with a novel point-of-purchase advertising piece for its phonograph needles. The company's sales message appears on a flat disc that fits on the phonograph turntables in record dealers' audition booths. The copy warns against spoiling new records by using worn needles.

Allen B. Du Mont Laboratories, Clifton, N. J., has inaugurated a large-scale nation-wide color-TV training program for service personnel of its receiver distributors. A weekly school is being conducted under the direction of the Teleset Service Department in Paterson, N. J. This program is being augmented by a series of dealer color service clinics that will be held throughout the country this fall. Du Mont also opened a new display and demonstration room for its TV and electronic products on the 82nd floor of the Empire State Building in New York City.

Simpson Electric Co., Chicago, is continuing its series of black-and-white and color-TV service meetings, the latest being held in the Denver and Utah areas. Bob Middleton, Simpson field engineer, conducts the meetings.

RCA Tube Division, Harrison, N. J., reported that over 1,800 service technicians had already qualified for a home-study color-TV training course that it is offering with the purchase of

A Star Is Born...

Only EICO #232 Peak-to-Peak VTVM has all these Advanced Features ★

★ FOR THE FIRST TIME ALL CALIBRATION IS DONE WITH INSTRUMENT IN CABINET.

★ 7 non-skip ranges on every function — DC, RMS sine volts: 0-1.5, 5, 15, 50, 150, 500, 1500. (To 30 kv with HYP probe.) Res.: 0.2 ohms to 1000 megs. — *Uni-Form* 3 to 1 scale ratio assures extreme wide-range accuracy.

★ Flat freq. response 30 cps to 3 mc.

★ Measures directly peak-to-peak voltage of complex & sine waves: 0-4, 14, 42, 140, 420, 1400, 4200. Vital for TV servicing. Saves the cost of separate Peak-to-Peak Probe.

★ Modern styling, etched panel; compact, easily portable. Size: 8½" x 5" x 5".

★ Terrific time and trouble-saver! One probe for all functions — a "twist of the wrist" selects DC or AC (Peak-to-Peak & RMS) OHMS! (pat. pend.)

★ No annoying lead tangle, no back-and-forth prod changing. Positive-action, rugged!

NEW PEAK-TO-PEAK VTVM AT LOWEST COST
With Exclusive **Uni-Probe**

KIT \$29.95 **Factory Wired \$49.95**

Complete with UNI-PROBE at no extra cost

Excellent for your bench
Model 249 Peak-to-Peak VTVM with Giant 7½" Meter
KIT \$39.95 **Wired \$59.95**
Complete with UNI-PROBE

See this amazing engineering achievement at your jobber today. Write now for FREE latest catalog **CV-10**

EICO ELECTRONIC INSTRUMENT CO. INC.
84 Withers Street
Brooklyn 11, N. Y.
Prices 5% higher on West Coast. © 54

EARN Big Money!

TELEVISION ELECTRONICS RADIO-RADAR

Learn TV, Radio Servicing, Radar, Sonar, Electronics at home in your spare time by Christy Shop-Method Home Training. Covers all subjects. The only complete course. Repair television and radio sets of friends and neighbors. Service electronic equipment in factories, stores, hospitals. Earnings made while learning can pay for your training. **19 TRAINING INSTRUMENTS INCLUDED!** Learn by Doing. Rush name for FREE Book and FREE Sample Lessons. **CHRISTY TRADES SCHOOL**, Dept. T-206, 4804 N. Kedzie, Chicago 25.

BUY DIRECT MANUFACTURER TO DEALER

ANTENNAS-INSTALLATION HARDWARE AND ACCESSORIES

WRITE FOR CATALOG

Skysweeper inc.

P. O. BOX 68
McHENRY, ILL.

NOW! BECOME EXPERT AT RADIO-TELEVISION in 4 easy steps

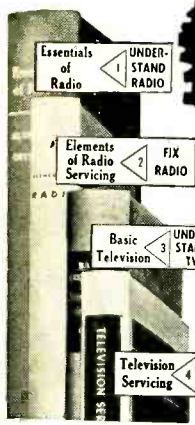

Tested training in theory, installation, repair—Up to date with color TV data

NOW you can do ANY Radio-TV installation, service, or repair job like an expert; operate field-testing equipment; understand problems of TV, FM-AM transmission, etc. Step into a good-paying job—or start your own service business. Train yourself AT HOME IN SPARE TIME with the McGraw-Hill Radio and Television Servicing Library.

2376 Pages—1611 Illustrations

PARTIAL CONTENTS ESSENTIALS OF RADIO. 800 pages, 433 illus. Circuit Analysis • Vacuum Tubes • Circuits: Detector • Amplifier • Tube Oscillator • Power Supply • Transmitting, Receiving • Etc.

ELEMENTS OF RADIO SERVICING 475 pages, 375 illus. Multimeters • AC Power Supply • Speakers • Antennas • Auto Radios • Push-Pull Output Stage

NEW BASIC TV, 2 Ed. 672 pages, 415 illus. Scanning • Synchronizing • Video Signal • Brightness Control • FM Alignment • Picture Tubes • VHF and UHF • Reception • New Section on Color TV

TELEVISION SERVICING 429 pages, 388 illus. Antennas • Transmission Lines • Test-pattern and Picture Analysis • Localizing Reception Troubles • Interference Remedies • Deflection Circuits • AND MUCH MORE!

The men who wrote this complete 4-volume Library are among the outstanding radio and TV instructors in America today. Every detail is clearly explained in over TWO THOUSAND PAGES of step-by-step instruction and nearly SIXTEEN HUNDRED "how-to-do-it" illustrations, cross-section diagrams, etc. The review questions and answers "nail down" everything you learn. At-a-glance "trouble-shooting" charts show how to diagnose instantly any radio or TV breakdown... and how to repair it expertly and quickly.

The Library will pay for itself many times over. It gives all you need to know for FM and TV in the FCC's 1st-class license exam; gives an experienced technician more confidence and skill.

SEND NO MONEY

Mail coupon below to examine complete four-volume Library FREE for 10 days. No obligation. Or you may examine individual books FREE for 10 days by checking the proper boxes in coupon.

FREE 10-DAY TRIAL COUPON
McGraw-Hill Book Co., Inc., Dept. RE-10
 327 West 41st St., New York 36, N. Y.

Send me for 10-day free examination the Radio and TV Servicing Library, 4 Vols. (Regular retail price is \$26.75; Special Course Price only \$21.95 in easy installments.) If not satisfied with Course, I will return it, pay nothing. Otherwise, I'll send \$1.95 plus delivery charges then and only \$4.00 monthly for 5 months.

If you wish to examine any of these books individually, check below the ones you wish us to send you for 10-Days' FREE EXAMINATION:

<input type="checkbox"/> Essentials of Radio, \$7.50	<input type="checkbox"/> Elements of Radio Servicing, \$5.25
<input type="checkbox"/> Basic Television, \$7.50	<input type="checkbox"/> Television Servicing, \$6.50

For any book I keep, I'll send \$2.00 plus delivery charges in 10 days, balance in easy monthly installments. (Print)

Name.....
 Address.....
 City..... Zone..... State..... RE-10

Employed by.....

WE PAY FOR DELIVERY if you send first payment of \$1.95 when ordering Library or full price when ordering individual books (prices above). Same return privilege. (This offer applies to U.S. only.)

its receiving tubes. The promotion continues through Nov. 15.

Workman TV Inc., Teaneck, N. J., has added an eyedropper dispenser to the quart-package unit of Wissh electronic contact cleaner and lubricant. JFD Manufacturing Co., Brooklyn, N. Y., has designed a new counter display for its Tele-Plex TV coupler.



Admiral Corp., Chicago, Ill., is conducting a series of television training schools for its dealer service personnel. Courses were held in Texas and North and South Carolina this summer. They will be followed by similar courses in other sections of the country this fall.

American Microphone Co., Pasadena, Calif., developed a new "package plan" for merchandising its line of phonograph replacement cartridges. The com-



pany now packs five cartridges in a clear plastic box and makes available to service technicians racks, labels, rubber stamps and other merchandising aids.

Production and Sales

RETMA reported production of 2,845,147 TV sets and 4,886,559 radios for the first six months of 1954. TV set production was off 26% from the same period last year, but June production of 544,142 compared with 524,479 for June 1953. RETMA noted that 8,394 color sets were produced in the period and 636,456 TV sets with u.h.f. facilities. The association also noted that retail sales of TV sets reached a record high of 2,805,760 units during the period as compared with 2,775,900 sold during the first six months of 1953. RETMA also announced that TV picture tube sales for the first six months totaled 3,957,238 as against 5,197,071 last year. Receiving tube sales for the first six months reached 165,709,060 compared with 243,160,348 for the first half of 1953. The association noted that cathode-ray tube sales for June had reached the high point of the year.

CLEAR TV PICTURE

119 MILES FROM STATION

WITH A **WINPOWER** TV TOWER

Eliminate tower-mounting headaches. Insure better reception and fewer service calls with America's Lowest Cost TV Tower.

Adapter locks mast in position or serves bracket for rotor.

"All-Angle" feet fits any roof.
5' or 10' HEIGHT

DEALERS PROFIT TWO WAYS

1. One man erects a neat, firmly supported antenna without special tools. Towers are light weight easy handling — individually packaged. Reduces objectionable guy wires.
2. Increase television sales with these permanent tower installations. Raise antennas to correct height with mast adapter. Reception goes up — service calls go down.

WRITE FOR PROFITABLE DEALER PLAN

WINPOWER

NEWTON, IOWA U.S.A.

Calendar of Events

Fall assembly meeting of the Radio Technical Commission for Aeronautics, September 30-October 1, Willard Hotel, Washington, D. C.

High Fidelity Show, September 30-October 2, Palmer House, Chicago.

Tenth Annual National Electronics Conference, October 4-6, Hotel Sherman, Chicago.

Audio Fair—Audiorama 1954, October 14-17, Hotel New Yorker, New York, N. Y.

First Annual New England High-Fidelity Music Show, October 22-24, Hotel Touraine, Boston.

Second National Conference on Tube Techniques, October 26-28, Western Union Auditorium, 60 Hudson Street, New York, N. Y.

Polytechnic Institute of Brooklyn, Symposium on Modern Advances in Microwave Techniques, November 8-10, Auditorium of the Engineering Societies Building, New York, N. Y.

New Plants and Expansions

Sylvania Electric Products dedicated its new 422,000-square-foot television set assembly plant in Batavia, N. Y., last summer.

RCA Service Co. established three new West Coast offices in Seattle, Hollywood, and San Francisco to handle its *Antennaplex* television systems.

JFD Manufacturing Co., Brooklyn, N. Y., has expanded its antenna laboratory facilities.

Pentron Corp., Chicago, held Open House at its new quarters 777 South Tripp Ave.

Chicago Telephone Supply Corp., Elkhart, Ind., opened a new West Coast office in Los Angeles.

Northwest Radio and Television School, Portland, Ore., opened a new \$100,000 building housing its offices, studios, and laboratories.

S. & A. Electronics, manufacturers of Target antennas, moved to new quarters in Toledo, Ohio.

Link Radio Corp., New York, N. Y., a new company, took over the rights and assets of the former Link Radio Corp., a Delaware corporation. Murray Platt is president of the new company.

General Radio Co. opened a branch engineering and sales office in Silver Spring, Md.

Business Briefs

... Gramer-Halldorson Transformer Corp., Chicago, is the new name of Gramer Transformer Corp., according to an announcement by James M. Blackledge, president.

... Tectum Corp., Newark, Ohio, purchased 80% of the stock of Alliance Manufacturing Co., Alliance, Ohio. Purchase will not affect local management.

... Raytheon Manufacturing Co., Waltham, Mass., produced its millionth junction transistor which was presented to Gov. Christian A. Herter of Massachusetts by Charles F. Adams, Jr., president of Raytheon.

... Burroughs Corp., Detroit, purchased Haydu Brothers of N. J., Plainfield, N. J., tube and component manufacturer. The company will continue operation under George K. Haydu, former president.

... Monson Manufacturing Corp., Chicago, was recently formed as a manufacturer of precision wire type resistors, capacitors, and other components. Harry Monson is president and general

Sales-builders

by **TACO**

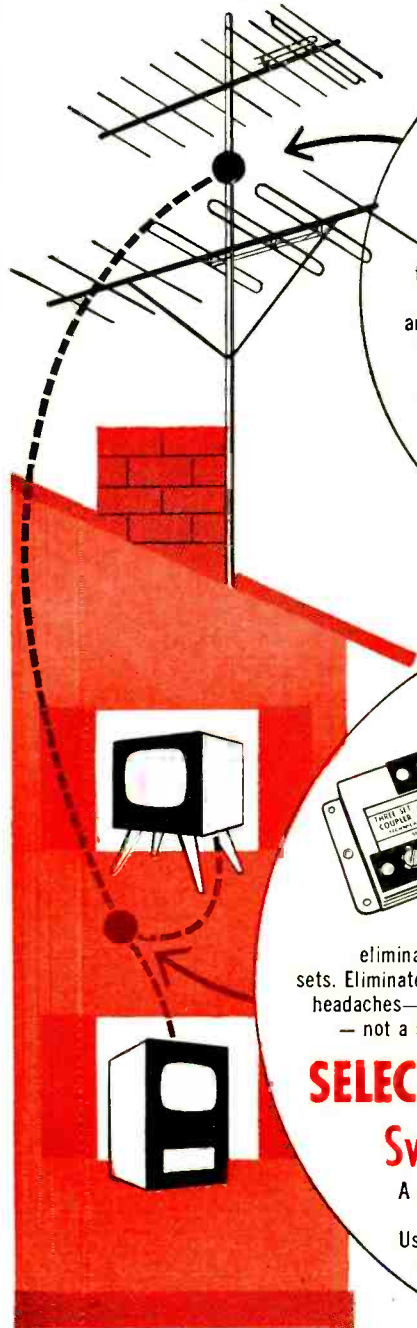

MAGI-MIX ANTENNA Couplers

An extremely efficient band pass filter permitting the use of a single transmission line with the following antenna combinations:

Cat. No. 1425A High-band and low-band VHF antennas

Cat. No. 1460 UHF and VHF antennas

Cat. No. 1465 Two UHF antennas

Cat. No. 1433 VHF high-band, VHF low-band and UHF antennas

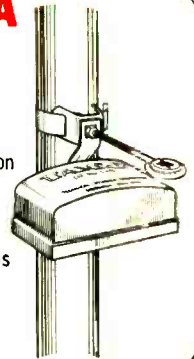

MULTI-SET Couplers

Three models—Cat Nos. 820-2; 820-3; and 820-4 permit two, three, or four set operation respectively from a single antenna installation. Units split signal equally between receivers and

provides necessary isolation to

eliminate interaction between

sets. Eliminate those trade-in headaches—sell a second set — not a second-hand set.

SELECTRONIC Switch

A multi-purpose, 300-ohm impedance switch with high-efficiency contacts for minimum loss. Used for manual switching from antenna to antenna, switching signal from one receiver to another, and ideal for use in high-fidelity signal switching.



Taco, the oldest and most respected name in antennas, offers you real SALES-BUILDERS in the line of antennas, accessories and promotional backing. You can't lose with Taco as your brand. Stop in and see your Taco distributor. Pick up your copy of the Taco catalog and see for yourself why Taco has been the STEADY LINE since 1932 . . .

TECHNICAL APPLIANCE CORPORATION
SHERBURNE, NEW YORK

In Canada: Hackbusch Electronics, Ltd., Toronto 4, Ont.

The
FINEST TAPE

Your
Recorder
Can Use...

Frequency Range: 20-20,000 cps
Lowest noise level • Uniform sensitivity
Minimum amplitude variation • Less distortion

600 feet on plastic reel net \$2.10
1200 feet on plastic reel net 3.30
2400 feet on metal reel net 7.71
SPLICE-FREE



THE TAPE
THAT MIRRORS

Available at Most Sound Dealers

ORRADIO Industries, Inc.
OPELIKA, ALABAMA

Export Division: Morhan Exporting Corp., New York, N. Y.
In Canada: Atlas Radio Corp., Ltd., Toronto

THE
ORIGINAL
SOUND



ALL RADIO AND TV TYPES
CLOSE OUT SET MFR'S SURPLUS TUBES

EVERY TUBE GUARANTEED 6 MONTHS

Branded—Bulk Packed in Original Mfr's. Nested Cartons or Individually Boxed

EVERY TUBE METER AND CHASSIS TESTED FOR TOP QUALITY

0A2	S.87	1U4	.46	6AT6	.36	6N7	.95	7F7	.64	12SA7GT	.62	35W4	.43		
0A3	VR75	.97	1U5	.40	6AV6GT	.79	6Q7	.49	7F8	.90	12SC7	.68	35Y4	.44	
0A4G	.60	1X2	.55	6AV6	.36	6R7	.49	7G7	.80	12SF5	.48	35Z5GT	.45		
0B2	.74	2A3	.90	6AX4GT	.57	6S3	.39	7H7	.36	12SJ7	.70	36	.35		
0B3	VR90	.90	2A5	.49	6B7	.93	6SA7	.40	7K7	.80	12SH7	.70	39-44	.35	
0C3	VR105	.95	2A6	.49	6B8G	.29	6SC7	.75	7L7	.77	12SJ7	.55	42	.40	
0D3	VR150	.85	2A7	.60	6B8E	.38	6SD7GT	.38	7N7	.77	12SL7GT	.49	43	.53	
024	.53	2B7	.62	6BA7	.55	6B8G	.29	6SF7	.58	7R7	.57	12SN7GT	.50	46	.45
1A4P	.35	2B7	.62	6BA7	.55	6B8G	.29	6SG7	.40	7S7	.59	12SQ7GT	.53	48	.45
1A5GT	.40	2K2	.39	6BA7	.55	6B8G	.29	6SH7	.60	7V7	.85	12SR7	.49	49	.38
1A7GT	.45	2X2A	1.14	6BA7	.55	6B8G	.29	6SL7GT	.49	7W7	.87	12S7GT	.53	50	.45
1A85	.38	3A4	.44	6BA7	.55	6B8G	.29	6SN7GT	.48	7Y4	.45	14A7	.57	51	.45
1B3GT	.67	3A5	.90	6B7	.93	6B8G	.29	6T7	.48	7Z4	.45	14AF7	.59	52	.52
1C5GT	.40	3ARGT	.39	6B7	.93	6B8G	.29	6U7	.45	7Z4	.45	14AF7	.59	53	.47
1C7G	.37	3B7	.39	6B7	.93	6B8G	.29	6V7	.85	7Z4	.45	14AF7	.59	54	.53
1D7GT	.75	3C6	.38	6B7	.93	6B8G	.29	6W7	.87	7Z4	.45	14AF7	.59	55	.47
1E7GT	.40	3F4	.71	6B7	.93	6B8G	.29	6X7	.45	7Z4	.45	14AF7	.59	56	.47
1F4	.40	3Q4	.48	6B7	.93	6B8G	.29	6Y7	.45	7Z4	.45	14AF7	.59	57	.53
1F5G	.44	3Q5GT	.48	6B7	.93	6B8G	.29	6Z7	.45	7Z4	.45	14AF7	.59	58	.56
1H4S	.40	3R4	.46	6B7	.93	6B8G	.29	6A7	.45	7Z4	.45	14AF7	.59	59	.56
1H5GT	.38	3V4	.50	6B7	.93	6B8G	.29	6B7	.45	7Z4	.45	14AF7	.59	60	.56
1I6G	.59	5T4	1.25	6B7	.93	6B8G	.29	6C7	.45	7Z4	.45	14AF7	.59	61	.43
1I4	.45	5U4G	.49	6B7	.93	6B8G	.29	6D7	.45	7Z4	.45	14AF7	.59	62	.42
1I6	.61	5V4G	.76	6B7	.93	6B8G	.29	6E7	.45	7Z4	.45	14AF7	.59	63	.53
1LA4	.59	5Y3G	.38	6B7	.93	6B8G	.29	6F7	.45	7Z4	.45	14AF7	.59	64	.77
1LA6	.59	6A5	.45	6B7	.93	6B8G	.29	6G7	.45	7Z4	.45	14AF7	.59	65	.77
1L34	.77	6A6	.45	6B7	.93	6B8G	.29	6H7	.45	7Z4	.45	14AF7	.59	66	.77
1LCS	.59	6A7	.80	6B7	.93	6B8G	.29	6I7	.45	7Z4	.45	14AF7	.59	67	.77
1LCS	.59	6A8	.80	6B7	.93	6B8G	.29	6J7	.45	7Z4	.45	14AF7	.59	68	.77
1LDS	.75	6A84	.42	6B7	.93	6B8G	.29	6K7	.45	7Z4	.45	14AF7	.59	69	.77
1LE3	.75	6A87	.71	6B7	.93	6B8G	.29	6L7	.45	7Z4	.45	14AF7	.59	70	.77
1LGS	.75	6AC5GT	.95	6B7	.93	6B8G	.29	6M7	.45	7Z4	.45	14AF7	.59	71	.77
1LH4	.75	6AC7	.68	6B7	.93	6B8G	.29	6N7	.45	7Z4	.45	14AF7	.59	72	.77
1LN5	.55	6AF4	.89	6B7	.93	6B8G	.29	6O7	.45	7Z4	.45	14AF7	.59	73	.77
1N5GT	.61	6AF6G	.75	6B7	.93	6B8G	.29	6P7	.45	7Z4	.45	14AF7	.59	74	.77
1P5GT	.56	6AG5	.47	6B7	.93	6B8G	.29	6Q7	.45	7Z4	.45	14AF7	.59	75	.77
1Q5GT	.55	6AG7	.90	6B7	.93	6B8G	.29	6R7	.45	7Z4	.45	14AF7	.59	76	.77
1R4	.81	6AH6	.88	6B7	.93	6B8G	.29	6S7	.45	7Z4	.45	14AF7	.59	77	.77
1R5	.47	6AK5	.59	6B7	.93	6B8G	.29	6T7	.45	7Z4	.45	14AF7	.59	78	.77
1S4	.55	6AL5	.35	6B7	.93	6B8G	.29	6U7	.45	7Z4	.45	14AF7	.59	79	.77
1S5	.40	6AQ5	.39	6B7	.93	6B8G	.29	6V7	.45	7Z4	.45	14AF7	.59	80	.77
1S46	.48	6AQ7G	.68	6B7	.93	6B8G	.29	6W7	.45	7Z4	.45	14AF7	.59	81	.77
1T4	.46	6ASS	.62	6B7	.93	6B8G	.29	6X7	.45	7Z4	.45	14AF7	.59	82	.77

MINIMUM ORDER: \$10.00. Terms: 25% with order, balance C. O. D. Please include postage.
All prices subject to change without notice. F. O. B. New York City. Mail Order Division:

TRANSAMERICA ELECTRONICS CORP.
115 LIBERTY ST., NEW YORK 6, NEW YORK

manager. He also heads the Chicago representative firm bearing his name. . . . Telrex, Inc., Asbury Park, N. J., licensed Delhi Metal Products, Delhi, Ontario, Canada, to manufacture its *Conical-V-Beam* antennas. Delhi will also represent Telrex in Canada for its rotary communications antennas for amateur, commercial, and Government use.

. . . Howard W. Sams, Indianapolis, has retained Ira Kamen, vice-president of Brach Manufacturing Co., Newark, N. J., to author a book on subscription television.

. . . General Electric Tube Department's manager of distributor sales, John T. Thompson, recently stated that technical developments now taking place in color TV will permit Americans to own an estimated seven and one-half million color TV sets in 1957.

. . . RCA Tube Division, Harrison, N. J., announced a special pro rata warranty policy providing one-year protection from date of installation on all RCA black-and-white television picture tubes purchased for replacement in home receivers.

. . . Tape Recorders Inc., Chicago, is the latest entry into the tape-recording manufacturing field. Hugh J. Daly is president.

. . . Fanon Electric Co., Howard Beach, N. Y., is now manufacturing a complete line of audio amplifiers, intercoms, and electric phonographs. Salo Nachtigall, formerly with Mark Simpson Manufacturing Co., is now devoting full time to the Fanon Company which he originally established as a contract manufacturer of electronic and electrical equipment.

. . . RCA will reduce patent royalty rates on its radios, black-and-white TV sets, black-and-white TV picture tubes, receiving tubes, and certain commercial radio apparatus, effective January 1.

Farnsworth Electronics Co., Fort Wayne, Ind., was formed as a domestic research and manufacturing division of International Telephone and Telegraph. The new company will handle industrial and defense electronics formerly carried on by Capehart-Farnsworth. Dr. Harvard L. Hull, former vice-president and general manager of research and development at Capehart-Farnsworth, becomes president of the new company. END

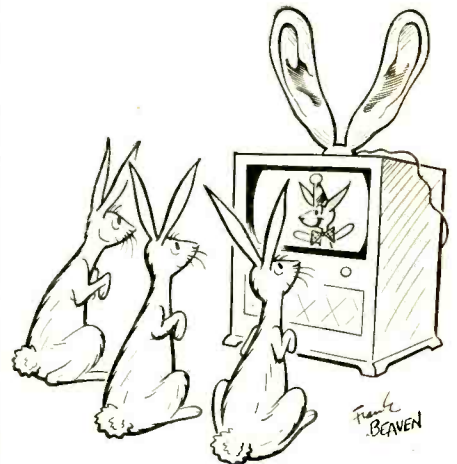

People



E. L. Dibble was promoted to the position of general sales manager, Consumer Products, of National Carbide and Carbon Co., New York City. He was formerly manager of the Eastern District.

Albert J. Borelli was promoted to sales manager of National Electric Products Corp.'s Television and Radio Dept., Pittsburgh, Pa. He was formerly chief engineer of the Electronics Division. He succeeds F. P. Yarussi who left the company to join a sales representative firm.



Keeton Arnett was named vice-president, Administration, of Allen B. Du Mont Laboratories, Inc., Clifton, N. J. He had served as general assistant to the president of the Du Mont company since 1951.

William W. Wexler joined Raytheon Manufacturing Co., Waltham, Mass., as advertising and sales promotion manager of the Equipment Sales Division. He was formerly with Murray Manufacturing Corp.



E. L. Anderson was appointed to the newly created post of sales promotion manager for United Motors Service Division of General Motors Corp., Detroit. He was formerly Midwest Division manager for Willys Motors.

M. Harvey Gernsback is the new president of Gernsback Publications, Inc., publishers of RADIO-ELECTRONICS and

the Gernsback Library Books. He succeeds his father, Hugo Gernsback, founder of the company who becomes Chairman of the Board. Hugo Gernsback will continue as editor of the magazine while M. Harvey Gernsback continues as editorial director.

Arthur L. B. Richardson was elected secretary and general counsel for Sylvania Electric Products, New York City. He succeeds John S. Leary who retired. Richardson has been general counsel for the company since 1953.



Gerhard G. (Gerry) Schneider was elected vice-president in charge of Production of National Union Electric Corp., Hatboro, Pa. He was formerly production manager and a member of the Operations Committee.



Obituaries:

Clarence E. (Scooter) Tonahill, owner of Scooters Radio Supply, Fort Worth parts distributing firm, died recently at his home.

Lawrence V. Wells, a principal in the

COYNE offers LOW COST TELEVISION RADIO-ELECTRONICS Training in Spare Time AT HOME



The future is YOURS in TV-RADIO!
A fabulous field—good pay—fascinating work—a prosperous future! Good jobs galore, or independence in your own business!

Coyne brings you the first *truly lower cost*, MODERN—QUALITY Television Home Training; training designed to meet Coyne standards. Not an old Radio Course with Television "tacked on". Here is MODERN TELEVISION TRAINING including working knowledge of Radio. Includes UHF and Color TV. No Radio background or previous experience needed. Personal guidance by Coyne Staff. **Practical Job Guides** to show you how to do actual servicing jobs—*make money early in course*.

Don't pay for a lot of costly extras—*pay only for what you learn!* The extras "thrown in" may look impressive, by and large they add little to what you actually **LEARN**—but how they do add to the price! With Coyne Television Home Training you pay only for your training, *no costly extras*.

B. W. COOKE, President **COYNE** FOUNDED 1899
ELECTRICAL SCHOOL

A TECHNICAL TRADE INSTITUTE CHARTERED
NOT FOR PROFIT

500 S. Paulina Street, Chicago 12, Dept. 74-HT4

ELECTRICITY ★ RADIO ★ TELEVISION ★ REFRIGERATION ★ ELECTRONICS

SEND COUPON FOR FREE PICTURE FOLDER

and full details, including easy Payment Plan. No obligation, no salesman will call.



COYNE ELECTRICAL SCHOOL
Television Home Training Div.
500 S. Paulina St., Chicago 12, Ill.,
Dept. 74-HT4

Send Free Picture Folder and details on Television Home Training. This does not obligate me and no salesman will call.

Name _____

Address _____

City _____ State _____

TRANSVISION

COMMUNITY AND MASTER TV Antenna Systems



**Assures Perfect Reception
on All Channels . . . on any
number of sets!**

**CUSTOM-DESIGNED
for your individual needs**

**Lowest Installation and Main-
tenance Cost of all Systems.**

In the difficult Metropolitan New York area, more TRANSVISION Master Antenna Systems were selected and proven out than any other system.

Want trouble-free reception? Pictures of remarkable clarity and stability? Then specify the Transvision Master TV Antenna System. Here are a few reasons why:

1. Highest power output allows longest cable runs.
2. Central system with only 1 point of service.
3. Operates up to 500 TV sets from 1 amplifier.
4. Lowest cost per outlet.
5. Maximum signal to each set with minimum interference.
6. Standard units are provided . . . but they may be modified to meet your special reception problems and layout. We also offer you:

FREE: Engineering advice. Send us your problem for quick solution.

Get full details now. Write:

TRANSVISION, INC.
Div. of Sightmaster Corp.
NEW ROCHELLE, N. Y.

rep firm of Haggerty-Wells Co., died at his home in Kalamazoo, Mich.

Personnel Notes

. . . James H. Carmine, formerly executive vice-president of Philco Co., Philadelphia, was elected president, succeeding William Balderston who is now Chairman of the Board. John M. Otter, former vice-president in charge of Consumer Products Divisions, is the new executive vice-president. Four other vice-presidents, Raymond B. George, vice-president, Merchandising; Frederick D. Ogilby, vice-president and general manager, Television Division; Samuel N. Regenstrief, vice-president—Manufacturing, Appliance Division, and Raymond A. Rich, vice-president and general manager, Appliance Division, were elected to the Board of Directors.

. . . Thomas M. Blake executive vice-president of Littelfuse, Inc., Des Plaines, Ill., was elected president, succeeding E. V. Sundt, chairman, who relinquished his office as president. Blake joined Littelfuse when it was incorporated in 1938.

. . . Robert A. Seidel was appointed executive vice-president, Consumer Products of Radio Corp. of America, succeeding Joseph B. Elliott who resigned to return to Schick Shaver Co. as president.

. . . Joseph C. Profita was appointed assistant manager, district sales and services, in the Equipment Sales Division of Raytheon Manufacturing Co., Waltham, Mass. He was formerly with Methods Engineering Council.

. . . Glen McDaniel was reappointed chairman of the RETMA Legal Committee. John B. Swan, Jr., Philco, was named chairman of the Traffic Committee, and Dan D. Halpin, Allen B. Du Mont, was reappointed chairman of the Sales Managers Committee.

. . . Robert C. Sprague, Sprague Electric Co., who last year won the RETMA Medal of Honor, was appointed chairman of the Annual Awards Committee for 1955. This committee nominates the recipient of the Medal of Honor.

. . . Carroll L. Hasler was appointed supervisor of Sales Administration for the Sylvania Electronic Products Sales Division. He has been with the company since 1953 in the Emporium, Pa. office. George Brodley was named merchandising assistant for the Sylvania Radio Tube and Television Picture Tube Divisions.

. . . N. A. Koetke, for many years associated with the transformer industry in advertising and promotion activities, joined the Gramer-Halldorson Transformer Corp., Chicago, as manager of Sales Promotion and Advertising.

. . . John C. Birrel was named placement director of Northwest Radio and Television School, Portland, Ore. He was formerly with station KWIL, Albany, Ore.

. . . Michael Muckley, formerly of Hallcrafters, Chicago, joined Espey Manufacturing Co., New York City, as special sales assistant for the company's new Overture high-fidelity unit. END

STAN-BURN E. D. ARKE

CATHODE RAY TUBE SPECIALS

ONE YEAR GUARANTEE

G.E.	STAN-BURN		
10BP4A	\$14.95	10BP4	\$10.20
10FP4A	21.10	12LP4	11.90
12KP4A	24.45	12LP4A	13.95
12LP4A	18.75	12QP4	11.90
12QP4A B1014		12PA	11.90
Dumont	21.00	12UP4A	14.50
12UP4B	28.75	14CP4	15.67
14CP4	24.50	15BP4	17.50
150P4 B1014		16KP4	17.50
Dumont	23.75	16DP4 or A	17.50
16AP4A	30.95	16JP4 or A	17.50
16BP4 (N.U.)	25.25	16QP4 or A	17.50
16GP4 or B	31.25	16FP4	17.50
16KP4 16RP4	24.20	16WP4	17.50
16PA		16PA	17.50
(Aluminum)	28.35	16PA4A	23.00
16JP4A (N.U.)	25.25	16EP4	19.00
16LP4	28.50	16EP4A	23.50
16WP4A	26.50	16CP4 or A	21.00
16GP4B	31.25	17BP4	18.50
17BP4	24.25	17CP4A	24.50
17BP4B	30.30	17CP4B	22.60
17CP4	23.90	19PA	23.00
17CP4B		19PA4	23.90
(Aluminum)	29.00	19AP4A	24.90
19AP4A	41.50	20CP4	23.95
20CP4	30.00	21EP4	25.50
20LP4	37.50	21AP4	26.50
21AP4	42.00	24AP4	49.00
21EP4	31.80		
21CP4A	35.00		
24AP4	78.50		

QUANTITY CRT USERS

We will give you DUD allowances if you ship them to us prepaid. 10 CRT's minimum shipment. WRITE FOR DETAILS.

AUTHORIZED DISTRIBUTORS for: General Electric, Kenrad, Tung-Sol, National Union, De Wald, Regal, Automatic and General Motors.

AUTOMATIC CUSTOM-BUILT RADIOS for Plymouth, Ford, Chevrolet and many others, always in stock. We carry a complete stock of HI-FIDELITY and SOUND EQUIPMENT. Send us your requests. We also carry a complete line of popular makes of Radio tubes at 5% to 10% discount. Also many other special purposes and transmitting types, and all electronic parts and equipment at lowest prices. Send us a list of your requirements for our quotations. Terms: 20% with order, Balance COD. All prices FOB. NEW YORK Warehouse. Minimum order \$5.00. Write for our latest price list and HI-FI Catalog to Dept. RE-10.

STAN-BURN RADIO and ELECTRONICS CO.

1697 BROADWAY • NEW YORK 19, N. Y.

!! MOTOR SPECIALS !!

- ECLIPSE REVERSIBLE MOTOR (Type Y-150) #BJ-8143, 1/2 H.P., 3800 RPM, 24VDC, Splined Shaft, O.D. 4" x 6" L. (Shpg. wt. 11 lbs.) BRAND NEW . . . WHILE THEY LAST! **\$6.95**
- AC-DC DELCO MOTOR (O.D. 2 3/8" x 2 3/4" . . . 5400 RPM, 27V, 1/2 shaft. **\$2.95**
- 1/40 H.P. AC MOTOR (Robins & Myers) 115V, 1600 RPM, 3/16" shaft, O.D. 2 1/4" x 4 1/2" L. With starting condenser (shpg. 6 lbs.) **\$4.95**
- 1/17 H.P. G-E MOTOR (Type SD) 1725 RPM, 110VDC, 4 1/2" Dia., 3/8" shaft, 110VDC 4 1/2" x 5 1/2" L. (Shpg. wt. 13 lbs.) **\$3.95**
- TOWER WHEEL & HOUSING (1-R-3) Use with any small motor. Moulded bakelite; 3" impeller **\$1.95**

!! Repair Your Own Speakers !!

- SAVE TIME—SAVE MONEY. Clear, Simple instructions supplied with every cone or repair kit order.
- Kit "A"—SPEAKER CONES . . . An assortment of popular sizes 4" to 12", incl. oval. Less voice coils. Kit of 12 asstd. **\$1.98**
- Kit "B"—DE LUXE CONE KIT . . . Same as above, but containing a larger variety of 20 asstd. cones **2.98**
- Kit "C"—SPEAKER REPAIR KIT . . . A Professional assortment of Voice Coil Forming, Rings, Felt, Chamois Lthr. Spiders, Shim Kit, Cement & Instructions **2.49**
- !! SPECIAL !! . . . BOTH KITS "A" & "C" for only **\$3.95**

!!! Over 10,000 Kits Already Sold !!!

And more "JEMBO" RADIO-TV-ELECTRONICS PARTS KITS GOING OUT EVERY DAY . . . WHY PAY MORE FOR PARTS when you can get them for a FRACTION OF THEIR VALUE? 17 LBS. CHECKLIST OF SWITCHES, CONTROLS, SOCKETS, WIRE, TV PARTS & DIAGRAMS, PHOTOFACTS, RESISTORS, CONDENSORS, PLUS DOZENS OF OTHER ITEMS (shpg. wt. 20 lbs.) **\$3.95** . . . A WHOPPING VALUE AT . . .

!! Hearing Aid Parts !!

- HEARING AID AMPLIFIER CHASSIS (2 tube) 2" x 5" x 1/2" Ready-wired. MAKE A REAL VEST POCKET RADIO OR AMPLIFIER adding only simple tuner & phone. WITH SCHEMATICS FOR A 2 or 3 TUBE SET. Less tubes & case. **\$2.49**
- SET OF 2 SUB-MINATURE TUBES FOR ABOVE **2.98**
- HEARING AID BONE CONDUCTION RECEIVER (8 1/2" x 8") . . . Makes sensitive MUSICAL CONTACT MIKE, DETECTORPHONE, ETC. Low impedance magnetite **1.98**
- CRYSTAL PICK-UP MIKE (1 1/2" x 1 1/4") . . . Hi-impedance, rubber shock mtd. **1.29**

"DIRECT FACTORY SPEAKER REPAIRS SINCE 1927" Also, orders \$3.00, 20% deposit req'd on all C.O.D.'s. Full remittance with foreign orders. Please add sufficient postage—excess refunded.

LEOTONE RADIO CORP.

67 Dey Street
New York 7, N. Y.

TERADO

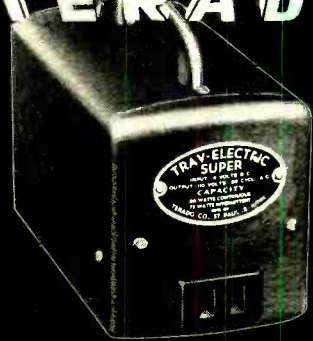

Trav-Electric CONVERTERS

provide
House Current

Anywhere

—from battery in car, truck, boat. At the beach—picnic grounds—at cabin—on trips—anywhere! Easy! No installation! Just plug Trav-Electric into cigar lighter on dash.

- | | |
|--------------------|-------------------------|
| ● Tape Recorders | ● Operates: |
| ● Electric Shavers | ● Dictating Machines |
| ● Radios | ● Small Electric Drills |
| ● Soldering Irons | ● Portable Phonographs |
| | ● Etc. etc. etc. |

6 Models 10 to 100 Watts

—a size for every need.

"Midget"

Model 6-11160
10-15 Watts

About as small as a pack of cigarettes.

\$11.95 LIST



PORTABLE PHONOGRAPH



DICTATING MACHINE



ELECTRIC SHAVEN

"JUNIOR"

Model 6-110
115 Cycle
30-40 Watts
\$12.95 LIST

"SENIOR"

Model 6-1160
Size 2 1/2" x 2 1/2" x 4 1/2"
35-40 Watts
\$15.95 LIST

"MASTER"

Model 6-51160
40-50 Watts
Size 4" x 5" x 6"
\$27.50 LIST

"SUPER"

Model 6-71160
(Shown at top of ad)
60-75 Watts
Size 4" x 5" x 6"
\$37.95 LIST

—and now, the "CHIEF"

NEW—JUST OUT—Model 6-81160—75-100 Watts—automatic on-off switch—\$49.95 LIST

See your Electronic, Hardware, or Automatic Jobber or Dealer

Terado Company

Designers and Mfrs. of Electronic Equipment
1057 Raymond Ave., ST. PAUL 14, MINN.

In Canada Write: Atlas Rad'co Corp., Ltd.
560 King St. West, Toronto 28, Ont.
Export Sales Division: Scheel International, Inc.
4237 N. Lincoln Ave., Chicago 18, Ill. U.S.A.
Cable Address—Harshel

technical Literature

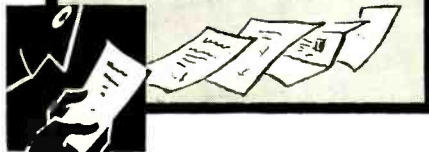

VOICE AND MUSIC REPRODUCTION

A 12-page catalog, No. 44B, on microphones, phono products, and tape recording heads which can be used in voice and music reproduction. The catalog includes a magnetic recording-head replacement chart and cartridge replacement chart. A numerical and application listing of crystal and ceramic pick-up cartridge is also given. One page is devoted to crystal phonograph pickups and needles, giving their prices and specifications.

Share distributors and Shure Brothers, Inc., 225 West Huron St., Chicago 10, Ill.

AUTO ANTENNA CATALOG

A catalog illustrating a new line of auto radio antennas. Cowl and fender mount auto radio antennas are described plus rear and deck mount

Any or all of these catalogs, bulletins, or periodicals are available to you on request direct to the manufacturers, whose addresses are listed at the end of each item. Use your letter-head—do not use postcards. To facilitate identification, mention the issue and page of RADIO-ELECTRONICS on which the item appears. UNLESS OTHERWISE STATED, ALL ITEMS ARE GRATIS. ALL LITERATURE OFFERS ARE VOID AFTER SIX MONTHS.

antennas. Featured in the catalog is the new *Snyder-Matic* auto antenna which raises or lowers three sections by means of finger-tip dash control.

Also illustrated is a series of free auto antenna displays.

Available by writing to Mr. Dick Morris at Snyder Manufacturing Co., Philadelphia 40, Pa.

TV REPLACEMENT GUIDE

A 40-page 1954 TV replacement guide and transformer catalog listing replacement transformers for over 6,800 models and chassis.

Chicago Standard Transformer Corp., Addison and Elston, Chicago 18, Ill., and distributors.

SERVICING PERIODICAL

Simpson Electric Co. is issuing a periodical, *The Technician's Timesaver*, every six weeks. The latest issue features an article by Bob Middleton on servicing and the use of test instruments.

Simpson Electric Co., c/o Service Department, 1101 E. 46 St., Indianapolis 5, Ind.

Color Servicing

IS NOW IN THE FAMOUS

Mandl's TV Servicing

A MASTER HANDBOOK FOR ANY SERVICE JOB
A COMPLETE COURSE IN TV SERVICING



The new section on color servicing and color circuits gives you the same clear how-to-do-it instruction that has made this book a favorite with servicemen everywhere. You'll be FULLY prepared to service any set, do the best job of installation or trouble shooting in minimum time, either for color or for black and white.

EASY to learn

Simple, clear explanations show you how each unit in the TV receiver functions, with lists of the flaws that may occur in it, what points in the circuitry cause them, how they affect other components, how they show up on the TV screen. Every step is fully illustrated with large clear schematics, photographs of test patterns, scope patterns and other helpful illustrations.

How to locate trouble quickly

A complete master trouble index gives the possible causes of distortions or faults in picture or sound, with references to the pages on which servicing instructions are given. You can quickly and easily diagnose the source of trouble and know just what to do about it.

Methods used by experts

You'll learn the practical time-saving methods used by the most experienced servicemen and technicians—ways of locating those hard-to-find troubles, simple signal tracing procedures, how to improve reception in fringe areas, how best to use test equipment. You'll learn the necessary why's and where's of TV reception, but won't be confused by unnecessary theory or involved math—just what you need in order to do a skilled servicing job is given here.

Recent improvements

In addition to the instruction on color—how it works, how to service color sets—you'll have the latest data on such improvements as cascade tuners, automatically focused tubes, new types of high frequency I.F. systems, transistors, UHF-VHF receivers. You'll learn TV for today and TOMORROW from this book.

Look it over without obligation. See for yourself how easy and practical this book is—how quickly you'll become expert with it, how useful it is on any job. Get a copy on

10-day FREE TRIAL

THE MACMILLAN COMPANY,
Dept. RE-5
60 Fifth Avenue • New York 11

Please send me a copy of the new Mandl's TV Servicing. I will either pay the full price of \$5.75 plus a small delivery charge or return the book in 10 days. (SAVE: send check or money order and we pay delivery charge.)

Signed _____

Address _____

This offer good only within continental limits of U.S.A.

NEW PATENTED RADAR ANTENNA

OPENS NEW HORIZONS TO TV VIEWERS

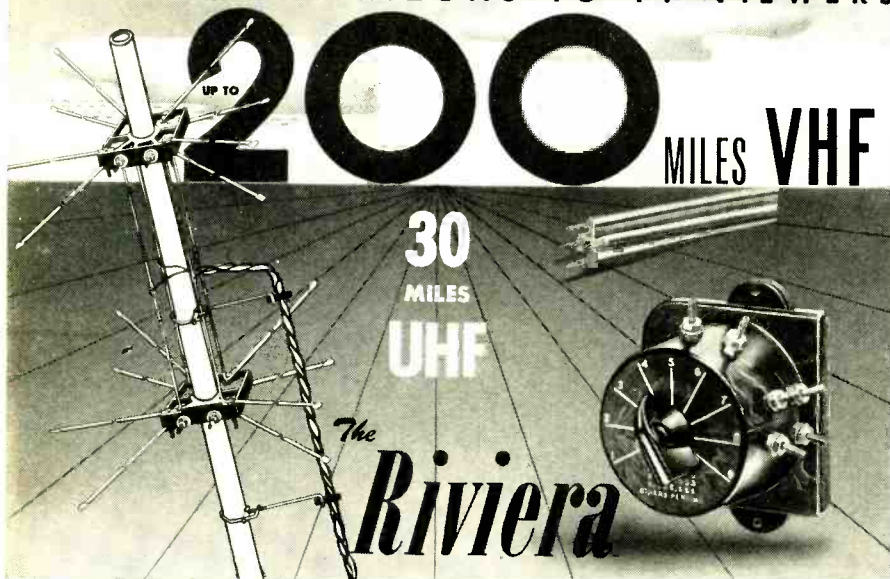

ALL DIRECTIONS • ALL CHANNELS 2-83
COLOR AND BLACK-WHITE
without ANY ROTOR MOTOR

These are the reasons why the "Riviera" is by far the most powerful VHF antenna on the market today!

1. Utilizes 16 elements 60" long, 1/2" diameter.
2. Utilizes a specially designed, extra low loss four conductor air-dielectric POLYMICALENE transmission line which has up to 50% less loss when wet than the finest conventional transmission lines.
3. The "Riviera" encompasses an electro-magnetic capture volume of well over 650 cubic feet, many times more than conventional antennas.
4. The antenna works on the revolutionary principle that the approaching wave front is elliptically rather than horizontally polarized.
5. The new specially designed 9 position electronic orientation switch, aside from changing directivity, maintains a consistently better impedance match over the entire UHF-VHF spectrum.
6. The above features combine to give the "Riviera" antenna greater usable gain at the TV set antenna terminals than the best of any competitive antennas using rotor motors.

This new wonder antenna, called the "Riviera", is already making history. Beyond any question of a doubt, and on an unconditional money back guarantee, it will positively outperform in the field under actual installation conditions, any and all competitive antennas on the VHF channels, with or without rotor motors.

POLAR PATTERNS

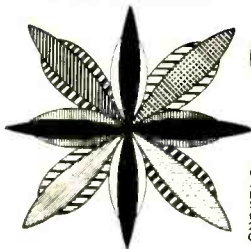

The polar directivity response patterns show the major lobes of the "Riviera" antenna on VHF. It shows the fullness of coverage in all directions of this remarkable, patented antenna as it is "turned" through each of the nine switch positions. Each degree of shading constitutes a different switch position. This excellent directivity response, which can be switched at will, plus the extremely high gains, clearly indicate why the Riviera is such a superior performer.

only
\$49.50
 LIST PRICE

Price includes:
 Complete Stacked
 Array • Stacking
 Bars • 9 Position
 Switch • Switch-
 to-set Coupler •
 2 Stand-offs, 7 1/2" •
 Complete instructions

IN UHF-VHF DISTRICTS . . . USE
The NEW Super 60
 100 MILES VHF • 60 MILES UHF

ALL CHANNEL ANTENNA CORP.

47-39 49th STREET, WOODSIDE 77, N. Y.

EXETER 2-1336

"1000 ELECTRONIC QUESTIONS & ANSWERS"

By R. J. Fredericks

Test YOUR Electronic I.Q. !!!

A new manual containing 1000 interesting problems and puzzles encountered in everyday, practical work. Chapters cover all principle topics, including test equipment, FM, TV, Hi-Fi, transmitters, receiver and many others. Ideal practice for service and lab technicians, amateurs, experimenters and students. ORDER TODAY! 10-day money back guarantee.

only
\$1 ppd.
 FULL PRICE

RADIO SOUND PUBLICATIONS

Box 38, Utopia Station, Flushing 66, N.Y.

THE BOOSTER BUY OF THE YEAR

Famous Masco TVB "Cascadian" Booster formerly \$42.50 now \$19.50. Dealer discount available



ELCRAFT ELECTRONICS
 32-28 49 St., L.I.C. 3, N.Y.

BUY DIAMONDS at RHINESTONE Prices!

Top Quality Receiving Tubes, individually boxed in attractive cartons, priced to build profits for you, satisfaction for your customers!

Write for details.

BARRACK, P.O. BOX 62, BROOKLYN 10, N. Y.

DIODE REPLACEMENT GUIDE

A 20-page brochure issued by Sylvania contains a listing of the types and numbers of diodes, and their equivalent Sylvania replacements, for the chassis and models of every major television set manufacturer.

Sylvania Electric Products, Inc., 1100 Main St., Buffalo 9, N. Y. 10 cents.

GERMANIUM DIODES

SP-2A, an 8-page bulletin, has been revised to contain the latest information on design, characteristics, and specifications of Hughes germanium diodes.

Hughes Aircraft Co., Culver City, Calif.

HI-FI BOOK

A 32-page book "Hi-Fi Is for Everybody" has been issued to give the layman a better understanding of high-fidelity systems. It discusses the amplifier, loudspeaker, record player, AM-FM radio tuner, tape recorder, and televiser.

Newcomb Audio Products Co., 6824 Lexington Ave., Hollywood 38, Calif. 25 cents.

MAIL ITEM

Sprague has made available reprints of "Beware the Service Bargain." Designed to promote better understanding between TV set owners and service technicians, it is a follow-up to the famous "Why Doesn't My Set Stay Fixed?" and "Are Servicemen Gyps?"

Sprague Products Co., North Adams, Mass. \$3.00 per 1,000, \$25.00 per 10,000.

RESISTOR GUIDE

A revised 1954-55 official resistor engineering guide, form S-074A, lists over 130 types of resistors and special products. Data given for each type include JAN or MIL equivalent, rated wattage, standard tolerances, temperature coefficient, maximum operating temperature, and approximate prices.

International Resistance Co., 401 N. Broad St., Philadelphia 8, Pa.

TRANSFORMER CATALOG

This 16-page catalog, No. 22, includes a table of contents on its cover. Audio transformers, autoformers, reactors, deflection yokes, filament transformers, focus coils, high-fidelity transformers, horizontal blocking oscillators, horizontal outputs, input transformers as well as interstage, isolation, modulation, and plate transformers are described.

Halldorson Transformer Division, Gramer Transformer Corp., 2734 N. Pulaski Rd., Chicago 39, Ill.

RADIOGRAM

The well-known Radiogram, a house organ published monthly by Scott Radio Supply, containing information and news for the service technician, ham, and radio and TV service associations, has come out with a 25th anniversary number, containing 32 pages instead of the usual four.

Scott Radio Supply, Inc., 266 Alamos Ave., Long Beach 2, Calif. END

RADIO SCHOOL DIRECTORY

MORE JOBS

than graduates

Demand for our engineering graduates exceeds supply. *Effective placement.* Study in this world-famed college established 1884. Quarters start January, March, June, September. *Approved for Korean Vets.*

Bach. Sc. degree in 27 months

Complete Radio Eng. courses . . . TV, UHF and FM. Also Mech., Civil, Elec., Chem., Aero. and Adm. Eng.; Bus. Adm., Acct. Small classes. Well-equipped labs. Modest costs. Prep. courses. Write *Jean McCarthy, Director of Admissions, for Catalog and Campus View Book.*



TRI-STATE COLLEGE

24104 College Avenue, Angola, Indiana

Get Your F.C.C. LICENSE Quickly!

Correspondence or residence preparation for F.C.C. examinations. Results guaranteed.

An FCC commercial operator license means greater opportunities and higher pay. We are specialists in preparing you, in a MINIMUM OF TIME, to pass FCC examinations for all classes of licenses. Beginners get 2nd class license in 5 weeks and 1st class in 3 additional weeks. Write for free booklet.

GRANTHAM School of Electronics

Dept. 101, 6064 Hollywood Blvd., Hollywood 28, Calif.

TELEVISION

PREPARE FOR A GOOD JOB!

BROADCAST ENGINEER
ELECTRONICS
RADIO SERVICING

Television Servicing

(Approved for Veterans)

SEND FOR FREE LITERATURE

BALTIMORE TECHNICAL INSTITUTE
1425 EUTAW PLACE, BALTIMORE 17, MD.



TV REPAIRMEN EARN TOP MONEY!

IN JUST 12 MONTHS, COMPLETE TV SERVICE TRAINING, INCLUDING COLOR TV. Stream-

lined course gives you all essentials for a good job as service technician. Graduates in great demand; jobs are plentiful in this growing field. Other electronic courses in radio operation and maintenance. Day or evening classes. Opportunity for employment in local industry. Approved for Korean veterans.

Write for Catalog 111 Today

INDIANAPOLIS ELECTRONIC SCHOOL
312 E. Washington, Indianapolis 4, Ind.

RADIO-TV ELECTRONICS



CREI graduates in big demand. Accredited by Engineers Council for Professional Development. Now classes start every month. Free placement service for grads. Courses offered—Radio Engineering, Broadcast or TV Engineering, TV, FM, AM Servicing. Write for free catalog. Approved for Vets.

CAPITOL RADIO ENGINEERING INSTITUTE

Dept. RE, 3224—16th St., N.W., Washington 10, D. C.



THE UNITED WAY

OCTOBER, 1954

GET INTO ELECTRONICS

You can enter this uncrowded, interesting field. Defense expansion, new developments demand trained specialists. Study all phases radio & electronics theory and practice: TV; FM; broadcasting; servicing; aviation, marine, police radio. 18-month course. Graduates in demand by major companies. H.S. or equivalent required. Begin Jan., March, June, Sept. Campus life. Write for catalog.

VALPARAISO TECHNICAL INSTITUTE
Dept. C Valparaiso, Ind.



CODE SENDING RECEIVING SPEED

Be a "key" man. Learn how to send and receive messages in code by telegraph and radio. Commerce needs thousands of men for jobs. Good pay, adventure, interesting work. Learn at home quickly through famous **Candler System**. Qualify for Amateur or Commercial License. Write for FREE BOOK. **CANDLER SYSTEM CO.**
Dept. 3-L, Box 928, Denver 1, Colo., U.S.A.

RADIO ENGINEERING DEGREE IN 27 MONTHS

Intensive, specialized course including strong basis in mathematics and electrical engineering, advanced radio theory and design, television. Modern lab. Low tuition. Self-help opportunities. Also B.S. degree in 27 months in Aeronautical, Chemical, Civil, Electrical, and Mechanical Engineering. G.I. Gov't approved. Enter December, March, June, September. Catalog.

INDIANA TECHNICAL COLLEGE

1510 E. Washington Blvd., Fort Wayne 2, Indiana



RCA INSTITUTES, INC.

A service of Radio Corporation of America
350 West 4th St., New York 14, N. Y.

OFFERS COURSES IN
ALL TECHNICAL PHASES OF
RADIO, TELEVISION, ELECTRONICS

Approved for Veterans
Write Dept. RE-54 for Catalog

EARN MORE MONEY— BE A PROFESSIONAL TELEVISION SERVICE TECHNICIAN



STEP INTO THE TOP PAY
\$5,000—\$10,000 A YEAR
CLASS. 7 MONTHS' SHOP
TRAINING QUALIFIES YOU.

If you want to reach your goal as a Successful Service Technician you will need plenty of "KNOW HOW" to qualify for the better servicing jobs or profitable shop ownership.

SEND FOR
FREE
BOOK TODAY!

WESTERN TV offers real experience on live equipment in our BIG SHOPS AND LABORATORIES in the shortest practical time under expert instructors. Graduates are in big demand because they have the "field experience" necessary for immediate "bench" or supervisory positions. You learn every phase of Radio and TV servicing (AM, FM, VHF, UHF). WTI men win fast promotion . . . can demand better pay . . . develop highly profitable businesses of their own with the latest and most PRACTICAL PERSONALIZED TRAINING BEHIND THEM. You concentrate all your time on being a PROFESSIONAL TV SERVICE TECHNICIAN — non-essential math and engineering theory omitted. YOU CAN EARN WHILE YOU LEARN. Special Finance Plan.

APPROVED FOR VETERANS. Find out how you can get into the TOP PAY GROUP — Send for this fact-packed book NOW!

WESTERN TELEVISION INSTITUTE

America's leading
Television
Servicing School

Western Television Institute Dept. E-10-4
341 W. 18th St., Los Angeles 15, Calif.
Without obligation, please send FREE fully illustrated booklet. (No salesman will call.)

NAME _____ AGE _____
ADDRESS _____
CITY _____ ZONE _____ STATE _____

Become an

ELECTRICAL ENGINEER

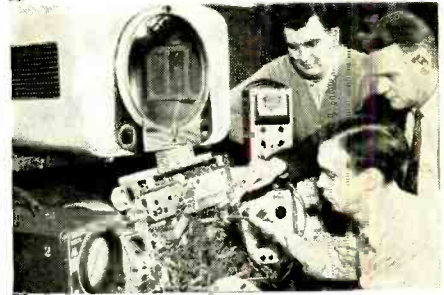

Major in Electronics or Power BS Degree in 36 months

Prepare now for a career as an electrical engineer or engineering technician — and take advantage of the many opportunities in these expanding fields.

You can save a year by optional year-round study. Previous military, academic, or practical training may be evaluated for advanced credit.

Enter Radio and Television — courses 12 to 18 months

You can be a radio technician in 12 months. In an additional 6-months you can become a radio-television technician with Associate in Applied Science degree. Color television instruction is included in this program.

These technician courses may form the first third of the program leading to a degree in Electrical Engineering. Twenty-one subjects in electronics, electronic engineering and electronic design are included in these courses.

Courses also offered: radio-television service (12 mos.); electrical service (6 mos.); general preparatory (3 mos.).

Terms — January, April, July, September

Faculty of specialists. 50,000 former students—annual enrollment from 48 states, 23 foreign countries. Non-profit institution. 51st year. Courses approved for veterans. Residence courses only.

MS-6A

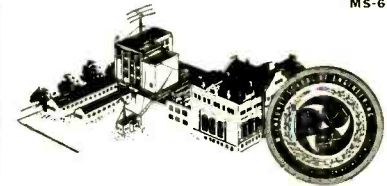

MILWAUKEE SCHOOL OF ENGINEERING

MILWAUKEE SCHOOL OF ENGINEERING
Dept. RE-1054, 1025 N. Milwaukee Street
Milwaukee 4, Wisconsin

Send FREE illustrated booklets
 Career in Electrical Engineering
 Career in Radio-Television.

I am interested in _____ (name of course)

Name _____ Age _____

Address _____

City _____ Zone _____ State _____

If veteran, indicate date of discharge _____

TOP QUALITY TUBES ONE YEAR GUARANTEE BELOW MFRS' PRICES!

Type	Price	Type	Price
0A2	.89	6A8	.69
0A3 VR75	.65	6AB4	.45
0A4G	.65	6AB7	.75
0B2	.74	6AC5GT	.99
0B3 VR90	.98	6AC7	.71
0C3 VR105	.98	6AF4	.89
0D3 VR150	.89	6AF6	.75
0Z4	.54	6AG7	.95
1A5GT	.43	6AH6	.99
1A6	.37	6AJ5	.59
1A7	.49	6AK5	.49
1AB5	.39	6AL5	.33
1AX2	.63	6AM8	.69
1B3	.59	6AQ5	.45
1D8GT	.77	6AR5	.39
1C4	.49	6AS5	.48
1G6GT	.55	6AT6	.37
1H5GT	.53	6AH6	.43
1J6G	.59	6AV5	.79
1K4	.45	6AV6	.37
1L4	.45	6B7	.95
1L6	.79	6B8G	.53
1L8A	.79	6B8H	.42
1L8B	.79	6BA7	.56
1L8C	.79	6BC5	.52
1L8D	.52	6BD6	.44
1E3	.78	6BE6	.39
1L8E	.77	6BG6	1.24
1L8F	.78	6BH6	.44
1L8G	.77	6BJ6	.44
1L8H	.78	6BK7A	.95
1NS	.61	6BL7GT	.85
1PSGT	.56	6BN6	.79
1Q5GT	.59	6BQ6	.82
1R5	.49	6BQ7A	.88
1S4	.58	6BZ7	.79
1S5	.49	6C4	.39
1S6	.48	6C6G	.64
1T4	.48	6C8G	.85
1U4	.39	6C8H	.85
1V	.69	6C9G	.45
1X2A	.55	6CD6	.95
2A3	.95	6CF6	.64
2A6	.49	6CL6	1.05
2A7	.64	6CS6	.55
2B7	.62	6D6	.69
2X2	.39	6DR6	.98
2X2A	1.15	6E5	.48
3A4	.44	6E6	.35
3A5	.93	6F7	.93
3A8	.60	6G6	.65
3B7	.39	6H6	.49
3D6	.39	6J5	.48
3LF4	.79	6J6	.48
3Q4	.57	6JAG	.95
3Q5GT	.55	6K6GT	.45
3S4	.50	6K7	.39
3V4	.42	6K8G	.65
5T4	1.28	6L7G	.59
5U4G	.58	6M7	.98
5V4	.82	6Q7	.49
5V3GT	.38	6R7	.98
5Z3	.44	6S4	.42
6A3	.89	6S7G	.59
6A6	.47		
6A7	.82		

We specialize in TUBES—Receiving, Transmitting and Special Purpose, etc.—serving the industry for years. More than 3000 different types in stock for IMMEDIATE DELIVERY! Because of the extreme care and precision used in testing our tubes in our fully equipped labs, and retesting at time of shipment—we readily guarantee every tube—not for 3 or 6 months—but for ONE FULL YEAR! All tubes individually boxed in handsome 3-color cartons.

Buy ELECTRON TUBES... to RESELL at a PROFIT

Type	Price	Type	Price	Type	Price
6SA7	.40	7A5	.59	12A8GT	.63
6SC7	.79	7A6	.69	12AL5	.42
6SD7GT	.38	7A7	.69	12AT6	.39
6SF5	.45	7A8	.59	12AT7	.68
6SF7	.59	7AH7	.56	12AU6	.39
6SG7GT	.40	7B4	.44	12AUV	.53
6SH7	.60	7B5	.59	12AV6	.44
6SH7GT	.50	7B6	.59	12AV7	.60
6SHT	.71	7B7	.59	12AV8	.49
6SL7GT	.52	7C4	.58	12AX7	.59
6SN7GT	.52	7C5	.49	12BA6	.47
6SQ7	.41	7C7	.65	12BA7	.59
6SR7	.45	7E5	.59	12BD6	.49

THIS MONTH'S SPECIALS

Our new policy brings you greater tube savings than you thought possible! As a GOODWILL offering, we are giving, each month, a number of popular tube types (listed in extra bold) AT PRICES BELOW OUR OWN COST! Look for these terrific offers of different types each month, in industry-wide publications:

6S5T	.60	7E6	.59	12BE6	.39
6S7T	.49	7F7	.65	12BH7	.65
6S7	.99	7F8	.95	12BY7	.59
6T7	.95	7H7	.75	12BZ7	.63
6T7G	.79	7I7	.59	12C8	.34
6T8	.59	7J7	.62	12C8GT	.45
6U7G	.45	7K7	.65	12F6GT	.35
6V3	1.02	7S7	.85	12H6	.57
6V4GT	.37	7T7	.91	12J5GT	.39
6W4GT	.45	7X7	.70	12K7	.55
6W6	.48	7Y4	.44	12K8	.58
6X4	.36	7Z4	.85	12Q7GT	.59
6X5GT	.29	10Y	.69	12S6T	.69
6X7	.74	12A6	.59	12S7	.45
6X8	.72	12A7	.99	12S6T	.75

EXPORT

- SE Invitan Solicitudes Para La Exportacion (Spanish)
- Convidamos Solicitacoes Para A Exportacao (Portuguese)
- Nous Invitons Des Demandes D'Exportation (French)

We are World Suppliers for Receiving & Special Purpose tubes of all types. Our prices are the most competitive on the Export Market—WE INVITE COMPARISON! Our Export Division is fully equipped to give you fast, efficient service.

New Complete Listing—Send For Free Copy!

Type	Price	Type	Price
12SH7	.75	CATHODE RAY	
12SJ7	.59	5BP1	3.98
12SK7GT	.44	5BP4	5.95
12SL7GT	.49	5CP1	5.95
12SN7GT	.38	7BP7	7.45
12SQ7GT	.56	12DP7	19.50
12SR7	.49	16HP4A	18.95
12T3	.69	16DP4	18.95
14A4	.59	XMITTING	
14A5	.59	Only a few types listed.	
14A7	.59	Send us your order for prompt shipment of ANY types you require!	
14A8	.65	1822	1.80
14B7	.69	1824	8.89
14C7	.62	1832	1.90
14F7	.67	1833	1.95
14F8	.95	20A	5.99
14H7	.59	2C40	6.95
14Y4	.69	2C44	.89
19	.49	2D21	1.40
19B6G	1.26	2J26	26.95
19F8	.44	3C24	1.75
22	.44	3225	2.31
25AV6GT	.84	304TL	5.95
25B06GT	.78	316A	2.50
25L6GT	.41	446A	3.40
25Y5	.85	7158	1.50
25Z6	.44	717A	.58
25Z6GT	.44	721A	2.50
26	.34	7D21	1.40
32L7GT	.98	801A	.39
35B5	.44	803	2.90
35L6GT	.42	815	3.90
35W4	.37	826	.89
35Z6	.45	836	3.95
35Z6GT	.45	841	1.30
35Z6GT	.45	842	.60
35Z6GT	.45	844	6.85
35Z6GT	.45	855	.85
35Z6GT	.45	874	1.30
35Z6GT	.45	875	.54
35Z6GT	.45	895	1.30
35Z6GT	.45	954	1.30
35Z6GT	.45	955	.54
35Z6GT	.45	975	1.30
35Z6GT	.45	977	1.30
35Z6GT	.45	978	1.30
35Z6GT	.45	979	1.30
35Z6GT	.45	980	1.30
35Z6GT	.45	981	1.30
35Z6GT	.45	982	1.30
35Z6GT	.45	983	1.30
35Z6GT	.45	984	1.30
35Z6GT	.45	985	1.30
35Z6GT	.45	986	1.30
35Z6GT	.45	987	1.30
35Z6GT	.45	988	1.30
35Z6GT	.45	989	1.30
35Z6GT	.45	990	1.30
35Z6GT	.45	991	1.30
35Z6GT	.45	992	1.30
35Z6GT	.45	993	1.30
35Z6GT	.45	994	1.30
35Z6GT	.45	995	1.30
35Z6GT	.45	996	1.30

FREE OFFER!
7 Assorted 12, 7, 6, 1 and 2-volt type tubes. List Value a p p o x - \$23.00. FREE with every order for \$25.00 or more!

ELECTRON TUBE WHOLESALERS, INC.

140 DUANE STREET • NEW YORK 13, N. Y. • Phone: BArday 7-7616

Books

ELEMENTS OF MATHEMATICS FOR RADIO, TELEVISION AND ELECTRONICS, by Bernhard Fischer and Herbert Jacobs. Published by the Macmillan Co., 60 Fifth Ave., New York 11, N. Y. 5 1/2 x 8 1/2 inches, 569 pages. Price \$7.20.

Representing one of the better efforts in the field of mathematics for the electronic technician, this book features thoroughness coupled with simplicity. Unlike many texts of this type that drill the reader in some mathematical function and then leave him stranded without knowledge of practical application, this text constantly applies each new process and formula to an electronic component or circuit.

The early chapters of the text are devoted to a complete coverage of arithmetic. Decimals and fractions are applied to the solving of simple d.c. and a.c. circuits. With the development of squares, square roots, radicals, and geometry, the authors delve into vacuum-tube characteristics. Trigonometric functions are also discussed for solving complex a.c. problems.

At this point the text becomes slightly more complex, discussing negative numbers, algebraic expressions, and more advanced equations. Much of this is directly applied to the explanation of television nomenclature.

The remainder of the book covers increasingly complex calculations in the field of radio and television. Voltage dividers, square waves, advanced vacuum-tube calculations, impedance-matching problems, and logarithms as applied to decibels are discussed.

A final chapter covers the practical subject of business mathematics, presenting information for the operation of a radio and television shop, such as compound interest, amortization, and installment sales.

With a great deal of information on such subjects as radio hardware and electronic standards, the text rounds out a fine treatment of the mathematics of electronics.—JK

A TEXTBOOK OF RADAR, by the staff of the Radiophysics Laboratory C.S.I.R.O. Australia, second edition. Published by the Cambridge University Press, 32 East 57th St., New York 22, N. Y. 8 1/2 x 5 1/2. 617 pages. Price \$8.50.

This is the second edition of this book, the first appearing in 1947. The basic principles of radar, thoroughly described in the first 16 chapters, differ very little from the first edition. They include: the fundamentals of radar,

XCELITE Hand Tools
PREFERRED BY THE EXPERTS

NOW!

ON THE JOB OR AT THE BENCH

—THE NUT DRIVER YOU NEED, in a flash!

Open—ready for quick use

XCELITE No. 77 Kit

It has your most needed sizes—3/16, 7/32, 1/4, 9/32, 5/16, 11/32 and 3/8"—handles color coded to size, like ALL XCELITE NUT DRIVERS. Sturdy plastic kit keeps tools together. Why be without this time-saver? Typical XCELITE quality, too! Ask your supplier—and remember, he has the full line of XCELITE screwdrivers in the sizes and points you need, as well as our big line of pliers!

XCELITE, INCORPORATED
(Formerly Park Metalware Co., Inc.)

Dept. J Orchard Park, N. Y.

For Originality

LOOK TO XCELITE

When answering advertisements please mention **RADIO-ELECTRONICS**

NOW

at last

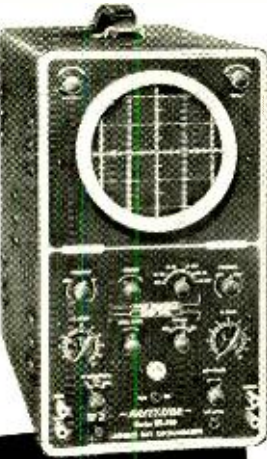

A Reliable, General-Purpose
5" Oscilloscope
 Priced at only **\$127⁵⁰**

The **NEW**
PRECISION
 MODEL
ES-520

PRECISION-engineered in response to industrial requirements for a reliable, low-cost, **FACTORY**-wired and **FACTORY**-calibrated scope for basic production and testing applications.

SPECIFICATIONS INCLUDE . . .

- ★ Push-Pull vertical drive. 20 millivolts per inch sensitivity.
- ★ 3-Step, frequency-compensated, vertical input attenuator.
- ★ Vertical frequency response 20 cycles to 500 KC within 2 DB
- ★ 1 volt, peak-to-peak, built-in vertical voltage calibrator.
- ★ Excellent vertical square wave response from 20 cycles to 50 KC.
- ★ Push-pull horizontal drive. 50 millivolts per inch sensitivity.
- ★ H⁺ frequency response 20 cps to 200 KC within 3 DB (at full gain).
- ★ Internal linear sweep 10 cycles to 30 KC. Neg. and pos. sweep synch.

Plus additional engineering and performance features never before incorporated in an oscillograph designed for such general application and at such economical price!

SERIES ES-520: In black ripple finished, rugged steel cabinet, 8 1/4" x 14 1/2" x 16 1/2". Complete with all tubes, including 5UP1 CR tube. Comprehensive instruction manual.

Net Price: **\$127.50**

Write directly to factory for complete data and specifications.

PRECISION Apparatus Co. Inc.
 92-27 Horace Harding Blvd., Elmhurst, L. I., N. Y.
 Export Division 45E Broadway, New York 13, U.S.A. • Cable: —Mechance
 In Canada: Atlas Radio Corp., Ltd. 360 King Street, W. Toronto 28

magnetron, oscillators, modulators, microwave theory, transmission lines, antennas, etc.

The last three chapters, dealing with the practical applications of radar, have been completely rewritten.

The new material consists of a chapter on military radar systems, covering ground-based, naval, and airborne radar; another on civil applications of radar in aerial and marine navigation and radar aids to surveying, and finally a chapter on the applications of radar to physical science.

This book is aimed at graduate and research students and engineers engaged in research and development in industry.—*J.K.*

SUBMINIATURIZATION TECHNIQUES FOR LOW-FREQUENCY RECEIVERS, by Gustave Shapiro. National Bureau of Standards Circular 545. Distributed by Government Printing Office, Washington 25, D. C. 8 x 10 1/4 inches, 64 pages. Price 50c.

This publication describes NBS research in miniaturizing airborne military equipment. Using novel and clever methods, a 12-tube superheterodyne was built to occupy only 55 cubic inches, as against 300 for a set using standard parts. This receiver tunes from 190 to 550 ke and weighs a little over 5 pounds.

The booklet describes a tiny gain control (1/2 inch in diameter, tape-wound over glass tubing); glass-aluminum capacitors; linear slug-tuning dial (by a screw with nonlinear pitch); new tracking methods; production hints. There are closeups of subassemblies, detailed mechanical drawings, construction information, and graphs. The NBS even designed a special (but relatively simple) machine for fabricating the special Litz wire used for the r.f. coils.—*I.Q.*

INDUSTRIAL ELECTRONICS, by R. Kretzmann. Published by Philips Technical Library. Distributed by Elsevier Press, Inc., 155 E. 82nd St., New York 28, N. Y. 6 x 9 1/4 inches, 250 pages. Price \$5.50.

A few years ago, industrial electronics was merely an offshoot of radio. Now it is an important field, with its own specialists and technicians. This book will aid those who design and maintain industrial control equipment. It is a practical book, but mathematics is included where needed.

Industrial electronics is concerned mainly with gas-filled tubes. Among these are the thyratron, senditron, ignitron, photocell, trigger and cathode-ray types. Part I of this book discusses these types and their basic circuits. Characteristics, photographs, and descriptions are provided.

Part II is twice as long. It discusses many devices and instruments, including welding controls, photographic timers, counters, lamp dimmers, paper registers, automatic inspectors of food cans, smoke detectors, door openers, etc. In each case the author gets to the point quickly and clearly. He presents a complete schematic, tells how the device works, and how to operate it.—*I.Q.*

END

2 NEW RIDER BOOKS PUBLISHED IN LATE SEPTEMBER

PICTURE BOOK OF TV TROUBLES, VOL. 1

(Horizontal AFC-Oscillator Circuits)

By the Rider Laboratory Staff

The first of a new "TV Case History" series, designed to provide the technician with a better understanding of how to diagnose TV receiver troubles by means of picture and waveform observation. All material in this book is the result of actual troubleshooting, done in the Rider labs! Over 65 "faulty" picture tube pattern illustrations . . . over 150 waveform illustrations (normal and abnormal!) A MUST for every service technician!

CHAPTERS: Pulse-width Type (Synchronizer); Phase Detector-Stabilized Multi-vibrator; Phase Discriminator-sine wave oscillator (Synchrolok); Phase Detector-sine wave oscillator.

Cat. #168. Approx. 80 (5 1/2" x 8 1/2") pages . . . only **\$1.35**

HOW TO USE TEST PROBES

By A. A. Ghirardi and R. G. Middleton

The only book of its kind! Written by two of the country's leading electronics experts, this book covers all types of test probes used with VOM's, VTVM's, and scopes. The one book that tells you what probe to use, where to use it, how to use it! Complete, step-by-step explanations, with practical examples of results and effects.

CHAPTERS: Resistive High-Voltage D-C Probe; Capacitance-Divider High-Voltage A-C Probe; Test-Cable Shielding and Test-Circuit Loading Fundamentals; Resistive Circuit-Isolation Probe ("D-C Probe"); Compensated R-C ("Low Capacitance") and Cathode Follower Circuit-Isolation Probes; Rectifying Probes for the VTVM; Demodulator Probes; Index.

Cat. #165. Approx. 176 (5 1/2" x 8 1/2") pages . . . only **\$2.90**

Buy these books from your jobber or book store today! If unavailable, write to: John F. Rider Publisher, Inc.

SPECIAL OFFER!

"Electricity For Boys and Girls"

. . . ONLY 25c!

Answers ALL the questions your youngsters ask about electricity! In simple, "boys-and-girls" language, this book clearly explains electricity, electrons, currents, atoms, batteries, generators, conductors, circuits, electrical terms, how to build a simple electric motor, and much more! Profusely illustrated! Perfect for every boy and girl! #4 (5 1/2" x 8") pages . . . only 25c!

MAIL THIS COUPON TODAY!

John F. Rider Publisher, Inc.

480 Canal St., New York 13, N. Y.

Please rush me . . . copies of **ELECTRICITY FOR BOYS AND GIRLS** @ 25c each! Payment enclosed.

NAME

ADDRESS

CITY STATE

E

HERE IT IS...

Columbia's DE LUXE Television Service Lite



Handier than a flashlight...

Now... with complete swivel for better lighting and easier servicing!

EVERY SERVICEMAN, experimenter, model-maker, needs this handy item. No need to work in the dark... ample light is provided by a 7 1/2-watt, 110-volt bulb that remains cool at all times.

Scientifically-designed, unbreakable aluminum reflector directs maximum light to point of work... A REAL TIME AND LABOR SAVER.

Carried by Leading Jobbers!

Have you seen our other TV service aids... "TV Service Cord," "TV Picture Tube Extension Cable," "Extension Cords, Hook-up Wire Assortment, TV Transmission Lines, Etc.

OUR LATEST CATALOG IS AVAILABLE UPON REQUEST!

Columbia WIRE & SUPPLY CO.
2850 Irving Park Road • Chicago 18, Ill.

ADVERTISING INDEX

Radio-Electronics does not assume responsibility for any errors appearing in the index below.

All Channel Antenna Corp.	142
Alliance Mfg. Co., Inside Front Cover	
Allied Radio Corp.	17
Almo Radio Co.	134
American Microphone Co.	85
American Photonic Corp.	96
Amplifier Corporation of America	127
Arkay Radio Kits, Inc.	128
Atlas Sound Corp.	118
Audel Publishers.	92
Barrack	142
Barry Electronics Corp.	146
Belden Mfg. Co.	109
Bell Telephone Labs.	29
Boland & Boyce, Inc.	131
Brooks Radio & TV Corp.	100, 101, 102, 103
Bruno-New Jersey, Inc.	126
Burslett Applique Co.	114
CBS Hytron (Div. of Columbia Broadcasting System)	93
Capitol Radio Engineering Institute	125
Centralab-Division of Globe-Union	103
Century Electronics Co.	18, 19
Channel Master Corp.	90
Chicago Standard Transformer Corp.	134
Christy Trade School	134
Cisin, H. C.	117
Ciarostat Mfg. Co., Inc.	11
Cleveland Institute of Radio-Electronics	111
Collins Audio Products Co., Inc.	147
Columbia Electronics Corp.	146
Columbia Wire & Supply Corp.	122
Concord Radio	86, 113, 139
Coyne Electrical & TV Radio School	111
Delco Radio (Division of General Motors Corp.)	7
DeVry Technical Institute	112
Dorian Electronics	112
Dynamo Magnetronics Corp.	116
Edlie Electronics	142
Ecraft Electronics	6
Electro-Voice	144
Electron Tube Wholesalers, Inc.	30, 113, 135
Electronic Instrument Co.	99
Electronic Measurements Corp.	124
Eric Resistor Corp.	133
General Industries Co.	122
General Test Equipment	126
Goldstar Co., The	123
Good, Inc. Don	124
Greylock Electronics Supply Co.	118, 120, 122, 124
Hallcrafters Co.	55-76
Heath Co.	112
Hershet Radio Co.	85
Hickok Electrical Instrument Co.	82
Hudson Specialties Co.	83
Hughes Research and Development Labs.	98
Indiana Technical College	127
Instructograph Co.	13
International Correspondence Schools	98
JFD Manufacturing Co., Inc.	114
Jensen Industries	119
Jones & Laughlin Steel Corp.	20
Kay-Townes Antenna Corp.	134
Leotone Radio Corp.	120
Lincoln Rec., Inc.	141
Macmillan Co., The	87
Malloy & Co., P. R.	136
McGraw-Hill Book Co.	115
Moss Electronic Distributing Co.	99
National Electric Products Co.	132
National Electronics of Cleveland	3, 27, 28
National Radio Institute	5
National Schools	104
Ohmrite Manufacturing Co.	112
Opportunity Adverts	138
Orradio Industries, Inc.	120
Oxford Electric Co.	105
Philco Corp.	22
Precision Development Corp.	133, 145
Precision Apparatus Co., Inc.	128
Progressive "Edu-Kits" Inc.	25
Pyramid Electric Co.	23
RCA Institutes, Inc.	147
RCA Victor Division (Radio Corp. of America) Back Cover	
Rad-Tel Tube Co.	92
Radelco Mfg. Co.	79
Radialia Corp.	78
Radio Craftsmen, Inc., The	78
Baltimore Technical Institute	142
Candler System Co.	21
Capitol Radio Engineering Institute	12
Grantham School of Electronics	145
Indiana Technical College	145
Indianapolis Electronic School	81, 114, 118, 121, 132
Milwaukee School of Engineering	98
RCA Institutes, Inc.	140
Tri-State College	108
Valparaiso Technical Institute	8
Western Television Institute	142
Radio Sound Publications	21
Radio Television Training Association	12
Raytheon Mfg. Co.	145
Rider, Inc. John F.	132
Rinehart & Co., Inc.	98
Rockbar	140
Rose Electronics, Inc.	16
Sams & Co., Inc., Howard W.	81
Service Instruments Co.	26
Skyline Mfg. Co.	135
Skysweeper, Inc.	140
Sprayberry Academy of Radio	86
Stan-Burn Radio & Electronics	108
Steve-El Electronics Corp.	8
Supreme Publications	148
Sylvania Electric Products, Inc.	137
Tab	126
Technical Applied Co.	141
Teltron Electric Co.	122, 140
Terado Co.	106, 107
Transamerica Electronics	138
Transvision, Inc.	10
Trio Manufacturing Co.	16
Triple Electrical Instrument Co., Inside Back Cover	
Tung-Sol Electric Co.	90
Turner Co.	91
United Catalog Publisher	122
University Loud Speakers, Inc.	86
V.A. Enterprises	80
Vaco Products Company	84
Ward Products Corp.	9
Webster Electric Corp.	63
Weico Mfg. Co.	24
Wen Products, Inc.	130
Weston Electrical Instrument Co.	14
Windsor Electronic Tube Co.	136
Wingard Co.	127
Winpower Mfg. Co.	144
Winston	127
Xcelite, Inc.	144
Zingo Products	127

RADIO SCHOOL DIRECTORY PAGE 143

STANDARD BRAND TUBES ONLY

FIRST QUALITY, INDIVIDUALLY BOXED, FULLY GUARANTEED (R.T.M.A.) TUBES

From the Five Top Manufacturers

- NO SECONDS •
- NO REBRANDS •

AUTHORIZED DISTRIBUTORS
CBS-HYTRON EIMAC WESTINGHOUSE

Tube Orders Over \$25.00, with full remittance, PREPAID to you in U.S.A.

Type	Net	Type	Net	Type	Net
0A2	85	6AX5GT	85	7E5	89
0B2	85	6B8A	75	7I7	89
0B3 VR90	82	6B8C	74	7J7G	125
0B6 VR105	85	6B8E	74	7J7	75
0D1 VR150	89	6B8E	72	7N7	95
0E4	55	6B8E	94	7Q7	98
1A7GT	90	6BGG	124	7X7	80
1B3GT	90	6BHG	85	12A7G	55
1H5GT	77	6B8E	85	12A77	105
1L4	60	6B8E	92	12A7G	65
1L6	95	6B87A	115	12A7U	84
1L6G	110	6B87GT	120	12A7V	55
1L8A	110	6B8E	122	12A7W	100
1L8E	110	6B8E	127	12A7W	88
1N5GT	95	6BQ7A	121	12A7X	90
1N34A	55	6B87GT	125	12A7X	84
1N38A	85	6B87GT	125	12A7Y	175
1N4	65	6B87	128	12A7Z	92
1R5	75	6C6	50	12B6G	98
1S5	75	6C6	50	12B6G	72
1T4	70	6C8E	75	12B6G	72
1U4	75	6C8E	75	12B6G	72
1V	103	6CL6	110	12B7H	100
1V2	90	6C6	210	12B7Y	105
1X2B	90	6D6	75	12B7Z	110
1Z2	325	6F4	340	12B7Z	82
2K2	35	6F5GT	68	12S7	80
3A4	30	6F6	70	12S7H	100
3B7	39	6F6G	68	12S7J	55
3C4	89	6F8G	85	12S7K	69
3Q5GT	90	6G6	85	12S7GT	65
3S4	75	6H6	52	12S7GT	83
3L4	90	6J4(RCA)	495	12S7GT	83
3U4	75	6J5	80	12S7GT	69
5AW4	150	6J8	80	12S7GT	110
5H4GY	150	6J7	75	14F7	205
5K4	110	6K7	60	15B6G	205
5V4G	97	6K7	60	19T8	110
5W4G	80	6L6G	110	25B06GT	135
5X4	110	6L6A	110	25B06GT	70
5Y3GT	48	6L8M	145	25W4GT	70
5Z3	75	6L7	80	25Z5	75
6AB4	100	6M7M	70	25Z5GT	75
6AB7	95	6Q7GT	80	26A6	175
6AD7	114	6S4	63	26A7GT	450
6AD7G	115	6S4T	69	26E6	125
6AF4	139	6S4T	69	26E6	72
6AG5	78	6S4T	69	26E6	72
6AG7	110	6S4T	69	26E6	70
6AH4GT	89	6S7	88	26E6	72
6AH5GT	89	6S7	88	26E6	72
6AM6	93	6SK7	65	26E6	70
6AJ5	130	6SL7GT	65	35Z3	50
6AK5	80	6SN7GT	79	35Z5GT	70
6AK6-W	50	6S07	63	30A5	75
6AK6	98	6T4	135	60B5	70
6AL5	60	6T8	99	90C5	72
6AN4	80	6U8	110	90L6GT	70
6AN5	365	6V3A	130	80	68
6AQ5	72	6V6GT	67	81	75
6AR5	73	6V6GT	67	83V	115
6AS5	75	6W6GT	82	84/8Z4	85
6AS6	265	6X5GT	52	117Z3	75
6AT5	375	6X5GT	52	117Z6	100
6AT6	28	7A7	100	1620	450
6AV4GT	100	7A8	69	5642	100
6AV5GT	115	7C5	75	5624	175
6AV6GT	85	7B7	75	5624	175
6AV7GT	110	7B8	78	6096	185
6AV8GT	57	7C4	80	6096	185
6AX4GT	84	7C5	80	6096	185

ORIGINAL JOBBERS' BOXED TUBES

IN STOCK—LATE DATES, at WHOLESALE PRICE LEVELS!

Above is only a partial listing of our huge stock. Types not listed may be ordered at approx. the same savings. Many new special purpose types in stock. We specialize in hard-to-get, obsolete types, which are no longer in production.

Ask for FREE News Bulletin and Handy Order Form

SPECIAL-PURPOSE TUBES

Write for our complete listing of XMTG, Industrial, Special-Purpose and Crystal Diodes. We stock over 2,000 types at excellent prices.

TWO-COLORED TUBE CARTONS, with new Safety Partitions, Prevents Tube Breakage. This Super-Gloss Red and Black Carton is the Most Distinctive Box Available Today! Minimum 100 any one size. Quantity prices on request. Boxes F.O.B., N.Y., N.Y.

SIZE	(GAUS, 6AL5, etc.)	EACH
Miniature	(6SN7, 6W4, etc.)	\$ 0125
LARGE GT	(183, 6BQ6GT, etc.)	015
LARGE G	(5U4G, 6BQ6G, etc.)	02

Terms: 25% with order, balance C.O.D. All merchandise guaranteed. F.O.B., N.Y.C.

PHONE: Rector 2-2562

BARRY ELECTRONICS CORP.
136-B LIBERTY ST. N. Y. 6, N. Y.

RAD TEL TUBES

GUARANTEED

1 FULL
YEAR

70% to 90%
OFF

300
TYPES
ALWAYS
IN STOCK

ALL TUBES
INDIVIDUALLY
BOXED

FOR QUALITY, PERFORMANCE, DEPENDABILITY

Type	Price	Type	Price	Type	Price	Type	Price	Type	Price	Type	Price
OA2	.74	5U4G	.55	6C4	.40	7A4	.47	12BA6	.49	25AV5GT	.83
OA4	.68	5W4GT	.50	6C5	.39	7A5	.59	12BA7	.60	25BQ6GT	.98
OB2	.81	5Y3GT	.37	6C6	.58	7A6	.69	12BD6	.45	25L6GT	.51
OC3	.72	5Y4	.51	6CB6	.54	7A7	.69	12BE6	.51	25W4GT	.59
OD3	.70	5Z3	.45	6CD6	1.11	7A8	.68	12BF6	.39	25Z5	.66
OZ4M	.65	6A6	.51	6CF6	.64	7AD7	.79	12BH7	.63	25Z6	.49
1A5	.49	6A7	.69	6CS6	.51	7AF7	.53	12BY7	.65	26	.45
1A7GT	.47	6AB4	.44	6D6	.59	7AG7	.69	12BZ7	.65	27	.39
1AX2	.62	6AC5	.69	6E5	.48	7AH7	.79	12C8M	.34	32L7	.89
1B3GT	.73	6AC7M	.86	6F5GT	.39	7B4	.44	12H6	.56	35	.58
1C5	.43	6AF4	.90	6F6	.59	7B5	.45	12J5	.42	35A5	.58
1E7	.29	6AG5	.56	6G6	.42	7B6	.69	12J7	.49	35B5	.52
1G6	.24	6AG7M	.99	6H6GT	.41	7B7	.49	12K8	.59	35C5	.51
1H4	.30	6AH4	.57	6J5GT	.43	7C4	.59	12Q7	.59	35L6GT	.51
1H5GT	.49	6AH6	.73	6J6	.52	7C5	.69	12S8GT	.62	35W4	.47
1L4	.46	6AJ5	.65	6J7	.43	7C6	.59	12SA7GT	.65	35Y4	.54
1LA4	.59	6AK5	.55	6K5	.47	7E5	.59	12SC7M	.63	35Z3	.59
1LA6	.69	6AK6	.59	6K6GT	.45	7E6	.30	12SF5	.50	35Z4	.47
1LB4	.69	6AL5	.42	6K7	.44	7E7	.59	12SG7	.51	35Z5GT	.47
1LC5	.59	6AM8	.78	6L6	.64	7F7	.79	12SJ7M	.67	36	.39
1LC6	.79	6AQ5	.50	6L7M	.68	7F8	.79	12SK7GT	.63	45	.55
1LD5	.59	6AQ6	.37	6N7M	.63	7G7	.89	12SL7GT	.57	45Z5	.49
1LE3	.59	6AQ7	.70	6Q7	.45	7H7	.59	12SN7GT	.52	46	.69
1LG5	.69	6AR5	.45	6R7	.69	7J7	.79	12SQ7GT	.56	50A5	.55
1LH4	.69	6AS5	.50	6S4	.48	7K7	.69	12SR7M	.49	50B5	.52
1LN5	.59	6AS6	1.49	6S7M	.79	7L7	.59	12V6GT	.46	50C5	.51
1N5GT	.67	6AT6	.41	6S78	1.69	SAME DAY SERVICE!					
1P5GT	.57	6AU4GT	.68	6S8GT	.53						
1Q5GT	.58	6AU5GT	.82	6SA7GT	.55	7N7	.69	12X4	.38	50L6GT	.61
1R5	.62	6AU6	.46	6SD7GT	.41	7Q7	.66	14A4	.69	50X6	.49
1S4	.59	6AV5GT	.83	6SF5GT	.46	7R7	.89	14A5	.59	50Y6	.49
1S5	.51	6AV6	.40	6SG7GT	.41	7S7	.79	14A7	.63	50Y7	.50
1T4	.58	6AX4GT	.65	6SH7GT	.49	7V7	.89	14AF7	.59	55	.49
1T5	.59	6B4	.54	6SJ7GT	.41	7X6	.54	14B6	.63	56	.49
1U4	.57	6BA6	.49	6SK7GT	.53	7X7	.70	14B8	.63	57	.58
1U5	.50	6BA7	.57	6SL7GT	.48	7Y4	.69	14C5	.79	58	.60
1V	.43	6BC5	.54	6SN7GT	.59	7Z4	.59	14C7	.79	70L7	.97
1X2A	.63	6BD5	.59	6SQ7GT	.46	12A6	.54	14E6	.75	75	.49
2A3	.30	6BD6	.45	6SR7GT	.45	12A8GT	.61	14E7	.88	76	.44
2W3	.38	6BE6	.51	6SS7GT	.42	12AL5	.37	14F7	.65	77	.57
2X2	.49	6BF5	.41	6T4	.99	12AQ5	.52	14F8	.69	78	.47
3A4	.45	6BF6	.37	6T8	.80	12AT6	.41	14H7	.59	80	.43
3B7	.27	6BG6G	1.25	6U5	.57	12AT7	.72	14J7	.30	83V	.68
3D6	.27	6BH6	.53	6U6	.59	12AU6	.46	14N7	.84	84/6Z4	.46
3E5	.46	6BJ6	.49	6U8	.78	12AU7	.60	14R7	.79	85	.59
3LF4	.69	6BK5	.80	6V6GT	.50	12AV6	.39	14S7	.89	117L7	.99
3Q4	.48	6BK7	.80	6W4GT	.47	12AV7	.73	14W7	.30	117P7	.99
3Q5GT	.69	6BL7GT	.83	6W6GT	.57	12AX4	.67	14X7	.69	117Z3	.37
3S4	.58	6BN6	.59	6X4	.37	12AX7	.63	14Y7	.62	117Z6	.69
3V4	.58	6BQ6GT	.98	6X5GT	.37	12AY7	.69	19BG6	1.39	807	.99
5AZ4	.59	6BQ7	.90	6X8	.75	12AZ7	.59	19T8	.69	866A	1.39
5T4	.79	6BZ7	.90	6Y6G	.48	12B4	.60	19V8	.79	1274	.30
						12X4	.38	24A	.39	Hi-Po #567	1.39

RED HOT PARTS BUYS • SEND FOR COMPLETE LIST OF PARTS VALUES!

Philco TV BOOSTER

No. 125



Made by Philco, famed for quality and precision in communications equipment. Completely self-contained, including 2 6J6 tubes... 1 for high channels and 1 for low channels.

and selenium rectifier. Plastic cabinet. In factory-sealed cartons, complete with instructions.

NEW LOW PRICE \$9.95

No. 97

WEN SOLDERING GUN



3 seconds on 120 Volt AC readies it for any soldering requirement, 250 Watt size. Also cuts plastic pipe (with special tip). Multi-useful. UL Approved. Built-in spotlight.

List price—\$12.95

9.71 ea.

Lots of 3 \$8.64 each

SELENIUM RECTIFIERS

Mfd. by FEDERAL			Mfd. by FEDERAL		
Item No.	DC-Ma.	Price	Item No.	DC-Ma.	Price
113	65	.50	118	300	1.39
114	75	.69	119	350	1.59
115	100	.79	120	400	1.59
116	150	.84	121	500	1.99
117	200	1.25			

RAD-TELTUBE CO.

Dept. RE-30

115 Coit St.,
Irvington 11, N. J.

"Integrity Is Our Chief Asset"

TERMS: A 25% deposit must accompany all orders—balance C.O.D. All shipments F.O.B. Irvington warehouse. ORDERS UNDER \$10—\$1.00 HANDLING CHARGE. Subject to Prior Sale.

PLEASE: Send full remittance... allow for postage and save C.O.D. charges! We refund all unused money!

Phone: Essex 5-2947

Tubes in Bold Type Cover 90% of Demand

NEW POCKET AC-DC VOM MULTITESTER Model 727c \$9.99 Plus 25c Ship in U.S.A.

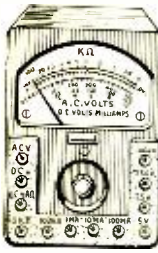

1000-OHM Per/V Reads AC & DC Volts 0 to 5, 25, 250 & 1000 Volts. DC mA: 0 to 1, 10, 100mA OHM: 0 to 10K & 100K HI-accuracy—1% wire wound resistors & HV deposited resistors. Rugged jewel edged IP Resonant micro-amp meter movement, excellent damping, extra long meter scales, with vivid red & black calibrations. The size of 2 packs of King cigarettes. 4 1/4" H, 4 1/4" W, 3 1/4" D. A must for every TV serviceman, ham, experimenter or beginner. Built ready to work into kit complete with test leads. Model 552 smallest precision built Hi-accuracy Pocket Multitester 1% deposited carbon resistors. Jeweled IP Resonant micro-amp meter movement. Extra long meter scale AC & DC volts: 0-10-250 & 500V. DC mA: 0-1 & 250 MA. OHMS: 0-10K. Minimum size 1 1/2" D. 4 1/4" H. With test leads \$6.99, plus 25c for shipping U.S.A.

OIL CONDENSER SPECIAL 2MFD 600VDC

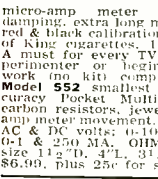

Aerovox Type P09 Steatite Insulators. Adjustable Mounting. Clamp. Case 2 1/2" dia. x 2 3/4" high. HFRAND NEW \$4.99; 10 for \$3.50

VARIABLE DC POWER SUPPLY



Full wave rectification, 6000Mfd filter Condensers. 600VDC. 0.5V to 12.5V at 200mA. Operates 115V/60cps. \$12.98 As above except 4 amp. Model 41FC \$20.98

866A KIT and XFORMER

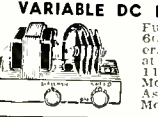

(2) 866A Tubes & Sockets, Transformer Rated PRT 115V/60cps Sec. 2.5VCT 10A. HV Insulation \$4.98

TOGGLE SWITCHES



SPDT 15A/125V Center Off—AN3022-1B \$6.99; C/2.50
SPDT 5A/125V used 1N 4541
SPDT 15A/125V Center Off
Mom. \$7.99; 3/52; 20/510
SPDT 15A/125V AN3022-3B
Sec. 3/51.25; 20/510.00
DPST 15A/125V AN3022-2R
69c; 5/52.50; 25/510.00
DPST 5A/125V BK1 \$4.99; 5/51.25
DPST 22A/125V HFRAND \$1.49; 2/51.98
4PDT 10A/125V \$1.98; 3/55; 20/330

TUBES

*From This Special List We Ship \$10.00 and Up Tube Orders At Our Expense (Post-paid) Within Continental Limits of U.S.A. 90 Day Gtd. When ordering mention 10RE.

0A2	.88	6AQ5	.52	6H6	.60	6Y6G	.88
0A3 VR75	1.37	6AQ6	.81	6L6C	1.12	6X4	.76
0B2	.96	6AQ7GT	1.29	6J5	.54	7F7	.82
0B3 VR90	.96	6AR6	3.27	6J7	.58	7G7	.82
0C3 VR105	.96	6AV6	1.09	6K6	.54	7H7	1.24
0D3 VR150	.92	6AS6	2.22	6K7	.58	7J7	.92
1B3 8016	.80	6AS7G	3.48	68A	3.68	7Y7	1.06
1L4	1.18	6AUG5	1.10	68GKT	1.08	7Y8	1.06
1L6	1.35	6AU6GT	.56	6L6G	1.08	12A7	1.45
1LDS	.98	6AU6	.56	6L6GAY	1.98	12AT6	.54
1P3	.78	6AV6GT	.96	6SA7GT	.66	12AT7	.89
1P5	.78	6AV6	.96	6S7GT	.66	12AX7	.89
1T4	.78	6AX4 6U4	.74	6S7	.66	12AV6	.52
1R5	1.29	6B4G	1.18	6S7GT	.66	12B7	.89
1U4	.52	6B7	1.09	6F5	.66	12B7G	.89
1R5	.52	6B8	1.09	6F5GT	.66	12BE6	.59
1U4	.52	6B8T	1.09	6G1	.61	12AW6	1.18
2A4G	1.18	6BC	1.63	6G1GT	.61	12AX7	.98
2X2	.42	6BD6	.83	6G2	.61	12BE6	.59
3R4G	1.20	6BE6	.54	6G2GT	.61	12BE6	.59
3R4G	1.20	6BE6	.54	6G3	.61	12BE6	.59
3R4G	1.20	6BE6	.54	6G3GT	.61	12BE6	.59
5T4	1.48	6BG6	1.58	6L7GT	.64	12BA6	.59
5U4G	.55	6BH6	.63	6N7GT	.68	12BA7	.59
5R4G	1.20	6BE6	.54	6N7	.68	12BA7	.59
5R4G	1.20	6BE6	.54	6N7GT	.68	12BE6	.59
6AC7	.71	6BK7	1.58	6S7	.66	12BE6	.59
6AG5	.71	6BL7GT	1.19	6S7GT	.66	12BE6	.59
6AC7	1.67	6C	.98	6U4	.74	12C8	.85
6AM6	.71	6C6Q6GT	1.20	6U4GT	.74	12C8	.85
6AJ5	1.40	6B7	1.65	6U8	.99	12H6	.64
6AK5	.92	6C5	.68	6U8GT	1.30	12H6	.64
6AK6	.92	6C5	.68	6V6GT	.52	12K8	.88
6AL5	.48	6C8	.59	6W4GT	.52	12Q7GT	.55
6AL7GT	.48	6F6GT	.79	6X5	.52	12S7GT	.88
6AN5	3.27	6F6GT	.79			12S7GT	.88

PRECISION RESISTORS FOUR MILLION IN STOCK All 1% Accuracy Gtd

ORDER ANY VALUE WE HAVE IT. REGULARLY \$1.00 PER 60c AND UP. TAB'S SPECIAL 35c EACH; 25c ea. 100 OF ONE VALUE \$20.00 10 ASSORTED VALUES (U-SELECT) \$3.00 INDICATE SECOND RANGE NO MFGRS CHOICE WE SHIP TYPE IN STOCK NOTE: 1 MEG & UP ADD 25c EA RESISTOR

2X 20MFD/450VDC	.69c	3 for \$1.95
3X 15MFD/450VDC	.98c	3 for 2.50
3X 20MFD/450VDC	.79c	2 for 1.29
25MFD/450VDC	.98c	2 for 1.95
20MFD/450VDC/25V	3 for 1.95	
30-15-10 mfd 250vdc	5 for 1.95	
10MFD 450V	.55c	3 for 1.20
Dual 5MFD 450V	.75c	3 for 1.50
Dual 10MFD 450V	.85c	3 for 2.00

YOU PICK THEM 39c WHILE THEY LAST LOTS OF 10

Your selection of 10 at 39c each or smaller quantity at indicated prices. ELECTROLYTIC CONDENSER FRESH STOCK

2X 20MFD/450VDC	.69c	3 for \$1.95
3X 15MFD/450VDC	.98c	3 for 2.50
3X 20MFD/450VDC	.79c	2 for 1.29
25MFD/450VDC	.98c	2 for 1.95
20MFD/450VDC/25V	3 for 1.95	
30-15-10 mfd 250vdc	5 for 1.95	
10MFD 450V	.55c	3 for 1.20
Dual 5MFD 450V	.75c	3 for 1.50
Dual 10MFD 450V	.85c	3 for 2.00

39c WHILE THEY LAST

YOUR PICK THEM 39c WHILE THEY LAST LOTS OF 10 Your selection of 10 at 39c each or smaller quantity at indicated prices. ELECTROLYTIC CONDENSER FRESH STOCK

2X 20MFD/450VDC	.69c	3 for \$1.95
3X 15MFD/450VDC	.98c	3 for 2.50
3X 20MFD/450VDC	.79c	2 for 1.29
25MFD/450VDC	.98c	2 for 1.95
20MFD/450VDC/25V	3 for 1.95	
30-15-10 mfd 250vdc	5 for 1.95	
10MFD 450V	.55c	3 for 1.20
Dual 5MFD 450V	.75c	3 for 1.50
Dual 10MFD 450V	.85c	3 for 2.00

TAB'S THAT'S A BUY BARGAINS—BARGAINS

Just off the press, "TAB'S" Scoop Sheet. Tools, Portable Radios, Phonos, Audio Equip, Radio Parts & Equipment. All items priced at special bargain prices. Write for the "TAB'S" Scoop Sheet.

TELEVISION ANTENNA

VEE CONICAL Broad response, all channel, power-impedance for fringe areas. \$8.95
FODED DIPOLE Hi & low antennas, all channel, sturdy construction. \$4.95
TV CONICAL ANTENNA All Channels, Sturdy 3 elements cross bar & clamp. \$3.95
DOUBLE V Ant. All Channel, Sturdy Cons. up to 100 ft. Swivel. \$3.95
WINDOW CONICAL All Channel. \$3.95
5 FOOT Interlocking Mast Sections, Hy Duty, rustproof. 2 for \$1.49; 10 for \$7

METER SALE 50% OFF REG. RESALE PRICE

0-1MADC 31 1/2" RND P/ MR35V00DCMA \$8.95 Reg. \$13.95
0-5MADC 31 1/2" RND/MR35W00DCMA \$3.95 Reg. \$5.95
0-100MADC 31 1/2" RND/MR35W100DC \$3.95 Reg. \$5.95
0-150VDC 31 1/2" RND Airflow "AN" \$2.98 Reg. \$4.95
0-80VDC Weston 301/31 1/2" 50/100 OHMS per Volt \$2.00 List \$3.95
0-150VDC 31 1/2" RND \$12.95 Reg. \$19.95
0-150VAC WESTGIB \$1.79
120-0-120VAC with-shunt "AN" \$4.98

TV & COAX CABLE

300 Ohm Twineax, Heavy duty 65 mil copper TV lead in. \$1.39 per ft. 2c; 100 ft. \$139
1000 Ft. \$11.95; 5000 Ft. \$50.00
300 Ohm Twineax, 100 Mil Extra heavy duty 100 ft. \$3.29
1000 Ft. \$24.00
RG8U 52 Ohm 100 Ft. \$11; 1000 Ft. \$98
RG11U 75 Ohm 100 Ft. \$11; 1000 Ft. \$98
RG59U 73 Ohm 100 Ft. \$5; 500 Ft. \$22
HiVolts 15KV Anode Wire 50 Ft. \$1.50

CIRCUIT BREAKER FUSES

PUSH TO RESET
Amps 3-5-7-10-15-20
En. 27c; 5 for \$1.00.
100 Amp Socket \$1.10 \$15
Circuit Breaker Fuse W/2 Mounting Clips .39c
Fuses 3AG Size, Operates up to 24 Volts Please State Current (Amps) Desired
Heimann Magn Bkrs. Approx. 0.22
7, 9, 12, 15, 20, 30, 40, 50, 75, 100
Ea. \$1.98; 12/20; 50/575
SA, D & CH Toggle Sw Bkrs. Amps: 3, 5, 10, 15, 20, 30, 40, 50, 75, 100
Klixon Thermal Push Button Bkrs Amps: 5, 10, 15, 20, 25, 30, 40, 50, 75, 100

HI-FI SPEAKERS

All 8 ohm, V.C., Alnico V Magnets, Tubulit Network, 2 wires needed for HP & FT Response Famous Hi-Fi Speakers Mfgs.
15" Coaxial Pm & 5" Tweeter, 25 watt/20-17500 cyc. Model P25CO \$23.75
12" Coaxial Pm & 5" Tweeter, 12 watt/45-15Kc Spec. \$12.75; 3 for \$35
8" Coaxial Pm & 2 1/2" Tweeter, 15000 cyc Model P8CO \$7.98; 2 \$15
12" HI-FI Pm 10 watt 35-14Kc \$9.95
8" HI-FI Pm 7 watt 45-14Kc \$7.25

AUDIO COMPONENTS

Electrovoice triply cart. \$1.98
GE RPX040 78 Goldtone \$5.25
GE RPX041 MG Goldtone \$5.25
RPX050 GE 0195 \$6.69
GE RPX052 Dual (D&S) \$17.75
GE RPX053 001 & 003 diamonds \$25.98
3GTG GTD Pm Pm 12" Replacement
RP1010 Dual .001 & .003 sapphire. \$1.95
RP1012 Dual .001 & .003 diamonds \$20.89
RP1013 78 or RP1015 001 sapphire \$1.35
RP1003 78 or RP1004 LP diamond \$10.89
RP1013 Dual diamond & sapphire. \$12.89
Replacement needles for all mks. phonos. Please specify model and make.
MG078 single sapphire. \$9c; 12 for \$5.98
MG079 single sapphire. \$1.35
MG078 Dual sapphire \$1.98; 12 for \$7.50
WRITE FOR "TAB'S" HI-FI GRAM

THAT'S A BUY

Dept. 10RE 111 LIBERTY STREET, NEW YORK 6, N.Y., U.S.A.

NEW SELENIUM RECTIFIERS

We specialize in Rectifiers, Power supplies to specifications. Immediate delivery.

Cur.	18/14	36/28	130/100	266/217
Volts	2.40	2.40	8.50	22.25
2AMP	2.10	2.40	10.50	22.25
4AMP	3.75	7.50	25.25	38.85
6AMP	4.50	9.00	33.00	54.85
10AMP	6.60	13.20	42.50	84.85
12AMP	8.20	16.25	46.00	99.85
20AMP	13.25	25.50	79.50	160.85
22AMP	14.85	27.50	86.50	190.85
30AMP	20.00	38.00	121.50	235.85
36AMP	25.00	48.50	158.50	295.85
50AMP	32.00	62.50	189.75	405.85
100AMP	60.00	120.00	380.75	795.85

Rectifier & Transformer 115V/60 cps inputs.
up to 14VDC at 12 Amps \$19.98
up to 28VDC at 4 amps \$14.98
up to 28VDC at 12 amps \$29.98
up to 28VDC at 24 amps \$63.98
up to 28VDC at 36 amps \$129.95
WRITE FOR POWER RECTIFIER CATALOG

NEW HIGH CURRENT PWR SUPPLIES GTD*

Variable 0-28VDC. Completely Built, Ready to Go. Full Wave Rectifier, Transformer, Variac, Volt & Amp Meters, Switch, Terminals & Fuse. In Hy. Duty Steel Cabinet. Standard 115V 60 Cy Input. 220V to Oper. \$1 year.

Stock	Continuous	With Meters
T28V5A 0-28VDC at 5 Amp.	\$47.75	
T28V12A 0-28VDC at 12 Amp.	89.00	
T28V24A 0-28VDC at 24 Amp.	129.95	
T28V50A 0-28VDC at 50 Amp.	239.50	

NEW RECTIFIER XFMRs

Sec. Primary 115V 60 Cps
4 Amp \$ 8.75; 2 \$15.75
12 Amp \$16.75; 2 \$29.95
24 Amp \$35.75; 2 \$59.95
18 Volt, 2 Amps \$2.25; 2 \$4.

NEW RECTIFIER CHOKES

CH07 4AMP /007HY .6R 10	\$7.95
CH08 6AMP /008HY .6R 12	\$14.95
CH004 24A /004HY /025R 20	\$29.95

12SF7GT	.84	CK536AX	.99
12S7	.80	CK538DX	.98
12S7GT	.80	CK540DX	2.19
12S7GT	.54	CK543DX	1.35
12K7	.66	CK544DX	.99
12S7GT	.62	CK546DX	1.99
12S7GT	.62	CK547DX	2.49
12S7GT	.54	CK1005	.68
19V6	1.98	2050	1.48
25BQ6GT	.98	CK5672	2.49
25Z6	.98	CK5678	1.28
25Z6GT	.98	CK5678	3.74
25Z6GT	.98	CK5702	3.90
25Z6GT	.58	CK5703	1.29
28D7	1.94	Xtal Diodes	1.55
35L6	.67	IN218	2.10
35Z6GT	.54	IN222	1.22
40	.54	IN224	1.35
45Z3	.88	IN23A	1.89
50A5	.76	IN23B	2.00
50B5	.76	IN23C	2.00
50C5	.54	IN26	8.85
50L6GT	.62	IN27	1.55
6X4	2.68	IN28	1.64
6X4	.58	IN34	1.65
81	1.38	IN35	1.65
83V	1.12	IN38A	1.29
84/6Z4	.62	IN42	1.65
117Z6GT	.98	IN45	1.45
CK502AX	.98	IN47	4.00
CK502AX	.98	IN48	.47
CK505AX	.98	IN49	.47
CK512AX	1.45	IN54	.48
CK513DX	1.89	IN60	.60
CK532DX	2.80	IN63 K63	2.49
CK533AX	1.29	IN69	.98

TRANSFORMERS

All 115 V. 60 Cps Input TV & CR W/amp. for TV Tubes
HI VOLTS to 20KV (w/quadrupler coil) ALL tubes. PL & FT. 115V. W/amp. \$4.98
300 VDC/275 Ma Full-Wave: 6.4V/10.3A, 5.4V/8A, 2.5V/3A Hypert. (200MA) FT. \$11.49
2 for \$8.50; 6 for \$22.00
2500V/20MA, 6.3V/.6A, 2.5V/1.75A for RK41 Amp. Replacement \$7.98
1500VCT/5MA, 6.3VCT/3A, 6.3VCT/10A, 2.5VCT/5A Special \$7.95; 2 for \$14.00
950V/100MA, 5V/7.5A, 5V/2.5A, 45V/1A, 10V/1.5A W/amp. \$12.49
900V/35MA 2X2.5VA. XCLNT 1800V DRYER TWO X2M FT. WINDNG. \$2.25
7878/200MA, 78.7V, 1.5A \$2.98
770/2.5MA, 2.5V/3A, HVINS HMSLD includes FILTER PARTS, 4 scope. \$3.69
700VCT/70MA, 5VCT/2A, 6.3VCT/2.5A, \$4
550VCT/250MA, 5V/2A, 6.3VCT/2.5A, \$4
12.6V/3.5A, CSP RCA. \$4.50; 2 \$8.00
500VCT/60MA, 6.3V/4A HMSLD. \$2.98
420VCT/90MA, 6.3V/1.5A, 3V INPUT 12, 24 115VDC 11A & 230 VAC @ \$1.49
2X330VCT/10MA, EACH WINDG. \$3.49

FILTER CHOKES

61HY 15KVINS.	\$1.49; 2 \$2.49
10HY 125MA/UTC/CASED/	
12HY 125MA/UTC/CASED/	
50HY 125MA/UTC/CASED/	\$1.98
20HY/300ma or 15HY/400ma	\$2.95
12KVins	\$8.95
15HY 1/2 Amp 12KVins.	\$35.00
3Hy/40ma HI QI CSD 69c; 2 for .98c	
Dual 2Hy/300ma Cased.	.95c; 2 \$1.49
12HY 125MA/UTC/CASED/	\$1.98
2.5Hy 300ma 60/ohm.	\$1.69; 2 \$3.38

230 TO 115V AUTOTRANSFORMERS

For 220-240V/50-60 cps input. To 110-120V or step-up. With cord, Plug & Receptacle.
TP105 110V/230V \$2.25; 2 \$3.65
TPA100 100W \$4.00; TPA200 200W \$7.25
TPA250 250W \$6.75; TPA300 300W 7.25
TPA500 500W \$8.95; TPA750 750W 11.75
Model TPA1000 1000 Watts \$14.95
Model TPA1500 1500W/1.5KW \$22.50
Model TPA2000 2000W/2KW \$28.95
Model TPA3000 3000W/3KW \$49.95
WRITE FOR QTY. PRICES—EXPORTERS

TEST CORDS

8 FT Test Leads, Hyv Dty, 26 Strand W/Airator Clm. 3 Pair \$1.00
15 FT Extension SJ Cord, Hyv Dty, Rubber Insul., \$1.00
4 FT Flexible Instrum Foot Leads, Red & Blk, 2 Pr. \$1.00
10 FT Line Cord & Plug Heavy Duty, 2 for \$1.00
TROUBLE LIGHTS (Crown) Extra Outlet & Switch in handle, 25 FT \$1.49; 3 \$4
EXTENSION CORD 3-Way Receptacle & Plug, 6 Ft ea, 24c; 10 \$2.10; 12 Ft ea, 35c; 10 \$2.90

SOCKET ASSEMBLIES

1 1/2" JEWEL BAYONET SOCKET \$33c ea. Lots of 5 \$1.50
DIALCO-3110 "Pilot Light" 115V \$2.00
DIALCO-95408 Neon Panel Light, Red, Amber & Clear, Reg. 98c. 79c; 12 for \$6

OIL CONDENSERS NEW WAREHOUSE LIST

.0025MFD 25KV	\$4.00; 2 for \$7.00
.0016MFD 15KV	\$4.00; 2 for \$12.00
2X 1MFD 2000V	\$1.39; 2 for \$2.00
1MFD 25	

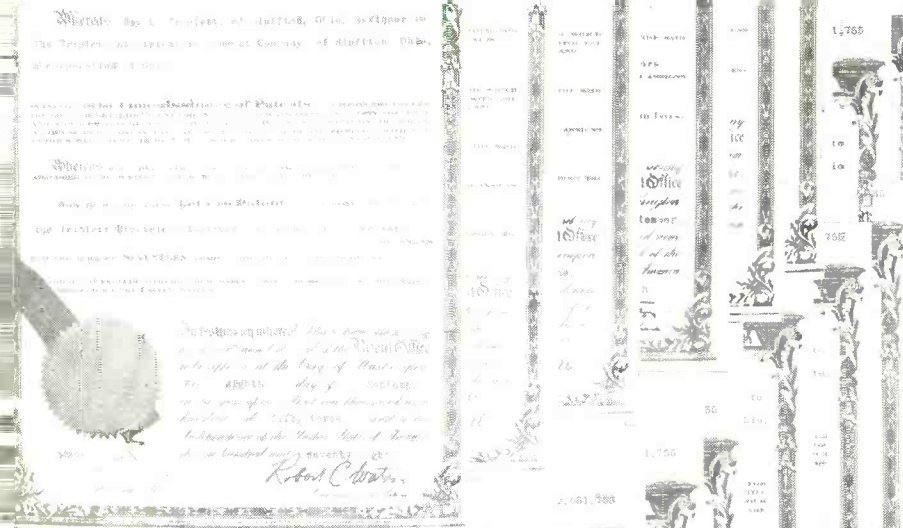

**THESE
INSTRUMENTS
ARE
BACKED
BY
63**

TRIPLET

PATENTS

proof of 50 year's research



MODEL 630—The "Smoothie" streamlining expresses advance design features such as selector switch of molded construction, completely enclosed; elimination of harness wiring, etc. AND a single control knob for all 34 ranges affording ease of operation and minimum burn out possibilities.
Price \$39.50



MODEL 630A ultra-accurate VOM designed for the laboratory where you need that PLUS in accuracy—*mirror scales* to eliminate parallax in making readings; $1/2\%$ resistors each mounted in its own insulated compartment; *compensated ohmmeter circuit*, resistance ranges are compensated for greatest accuracy over wide battery voltage variation. Single selector switch feature makes for ease of operation and eliminates possibility of burnouts through incorrect settings.
Price \$49.50

TRIPLET

**ELECTRICAL INSTRUMENT COMPANY
Bluffton, Ohio**

You see it once . . .



They view it day after day!



**BE SMART . . . install an RCA picture tube . . .
and be certain of a satisfied customer**

RCA takes no chances with its reputation for quality—its picture tubes are quality-controlled throughout production. And you take no chances when you install RCA picture tubes. Your customers will recognize the familiar RCA emblem—what it stands for: Top materials, top workmanship . . . top product! Build your reputation for fine service with the finest picture tubes made—RCA. See your local RCA Tube Distributor for your RCA Picture Tube needs—sizes from 3" to 27". There's an RCA Picture Tube for virtually every set, regardless of make, in RCA's "Balanced Line."



RADIO CORPORATION of AMERICA
ELECTRON TUBES

HARRISON, N.J.

ADV Plans, LLC

Copyright Notice:

The entire contents of this CD/DVD are copyright 2014 by ADV Plans, LLC. All Rights Reserved.

Reproduction or distribution of this disk, either free or for a fee is strictly prohibited. We actively monitor and remove listings on eBay thru Vero.

You are free to copy or use individual images in your own projects, magazines, brochures or other school projects.

Only the sellers listed here are authorized distributors of this collection:
www.theclassicarchives.com/authorizedsuppliers

Please view our other products at
www.theclassicarchives.com,
or our ebay stores:

[TheClassicArchives](#)
[ADVPlans](#)
[SuperShedPlans](#)

